

EureCard GRABLINK series
GRABLINK Value, GRABLINK Avenue,
GRABLINK Expert 2,
GRABLINK Value cPCI,
GRABLINK Expert 2 cPCI
Manual



Copyright © 2005 Euresys s.a.

Liège Science Park
Avenue du Pré-Aily, 14
B-4031 Angleur Belgium
Phone +32 4 367 72 88 • Fax +32 4 367 74 66
E-mail: info@euresys.com
Web site: www.euresys.com

This book is part of the documentation
provided with MultiCam.

For more information, refer to the
documentation provided in the latest
MultiCam release.

EureCard Grablink series Manual
January 2005



Copyright © 2005 Euresys s.a.
Printed in Belgium.

WARNING

EURESYS S.A. shall retain all property rights,
title and interest in the hardware or the software,
documentation and trademarks of EURESYS S.A.

All the names of companies and products mentioned in the
documentation may be the trademarks of their respective owners.

The licensing, use, leasing, loaning, translation,
reproduction, copying or modification of the hardware
or the software, marks or documentation of EURESYS S.A.
contained in this book, is not allowed without prior notice.

EURESYS S.A. may modify the product specifications
or change the information given in this documentation
at any time, in its discretion, and without prior notice.

EURESYS S.A. shall not be liable for any loss of or damage
to revenues, profits, goodwill, data, information systems
or other special, incidental, indirect, consequential
or punitive damages of any kind arising in connection
with the use of the hardware or the software of EURESYS S.A.
or resulting of omissions or errors in this book.

Thank you for buying a Euresys frame grabber.

**All our boards come with the “Euresys Solutions CD”
including free drivers and software libraries.**

**By following this manual,
you will install properly the board and the driver.**

**Enjoy Euresys software and hardware
industrial vision products !**

Table of Contents

Precautions of Use	9
Standard Compliance	11
Camera Link Compliance	13
GRABLINK Value Description	15
Product presentation	15
Block diagram.....	16
Board layout.....	17
Bracket layout.....	18
Camera connector.....	19
System connector.....	20
PCI requirements	21
GRABLINK Avenue Description	23
Product presentation	23
Block diagram.....	24
Board layout.....	25
Bracket layout.....	26
Camera connector.....	27
System connectors.....	28
PCI requirements	30
GRABLINK Expert 2 Description	31
Product presentation	31
Block diagram.....	32
Board layout.....	33
Bracket layout.....	34
Camera connectors	35
System connectors.....	36
PCI requirements	38
GRABLINK Value cPCI Description	39
Product presentation	39
Block diagram.....	40
Board layout.....	41
Bracket layout.....	42
Camera connector.....	43
System connector.....	44
PCI requirements	45
GRABLINK Expert 2 cPCI Description	47
Product presentation	47
Block diagram.....	48
Board layout.....	49
Bracket layout.....	50
Camera connectors.....	51
System connectors.....	52
PCI requirements	54

GRABLINK series Installation Instructions	55
Hardware installation procedure for Grablink Value, Grablink Avenue and Grablink Expert 2.....	55
Auxiliary board installation.....	56
Hardware installation procedure for Grablink Value cPCI and Grablink Expert 2 cPCI.....	57
Camera connection	58
Base configuration of Grablink Value, Grablink Avenue and Grablink Value cPCI.....	59
Base configurations of Grablink Expert 2 and Grablink Expert 2 cPCI.....	60
Medium configuration of Grablink Expert 2 and Grablink Expert 2 cPCI	61
MultiCam Installation Instructions	63
Hardware requirements.....	63
Windows installation.....	63
Linux installation.....	64
Technical Specifications	65
Grablink Value technical specifications	65
Grablink Avenue technical specifications	67
Grablink Expert 2 technical specifications	69
Grablink Value cPCI technical specifications	71
Grablink Expert 2 cPCI technical specifications	73

Contact Us

Euresys

General information: info@euresys.com

Web site: www.euresys.com

America	Asia	Japan	Europe
Euresys inc.	Euresys Pte. Ltd.	Euresys s.a. Japan	Euresys s.a.
		Representative office	Corporate Headquarters
500 Park Boulevard Suite 525	627A Aljunied Road #08-09 BizTech Centre	AIOS Hiroo Building 8F, Hiroo 1-11-2,	Avenue du Pré-Aily, 14
Itasca, Illinois 60143, USA	Singapore 389842	Shibuya-ku, Tokyo 150-0012, Japan	B-4031 Angleur, Belgium

America	
Toll free: 1-866-EURESYS Phone: +1 630-250-2300 Fax: +1 630-250-2301	Technical support: support.usa@euresys.com

Asia	
Phone: +65 6748 0085 Fax: +65 6841 2137	Technical support: support.asia@euresys.com

Japan	
Phone: +81 3 5447-1256 Fax: +81 3 5447-0529	Technical support: support.asia@euresys.com

Europe	
Phone: +32 4 367 72 88 Fax: +32 4 367 74 66	Technical support: support.europe@euresys.com

Precautions of Use

Warning:
Electrostatic sensitive device

Grablink boards may be damaged by electrostatic discharges. Follow the procedure hereby described and apply any general procedure aimed at reducing the risk associated to electrostatic discharge. Damage caused by improper handling is not covered by the manufacturer warranty.

Warning:
Electrostatic compatibility

Grablink boards are compliant with electromagnetic compatibility regulatory requirements. To ensure this compliance, it is mandatory to secure the card bracket with the relevant screw according to the procedure hereby described.

Warning:
Risk of electrical shock

Do not operate the computer with any enclosure cover removed. During the hardware installation, ensure the AC power cord is unplugged before touching any internal part of the computer.

Warning:
Heating device

In operation, it is normal that a Grablink board dissipates some heat. To ensure the adequate cooling effect of the fan equipping your computer, it is mandatory to correctly fit all enclosure covers, including blank brackets.

Warning:
Hot plugging forbidden

Uncontrolled plugging and unplugging of equipment may damage a Grablink board. Always switch-off the computer, the cameras and any relevant system device when connecting or disconnecting a cable at the frame grabber or auxiliary board bracket.

Warning:
Poor grounding protection

The computer and the camera can be located in distant areas with distinct ground connections. Poor ground interconnection, ground loop or ground fault may induce unwanted voltage between equipments, causing excessive current in the interconnecting cables. This faulty situation can damage the frame grabber or the camera electrical interface.

The user must follow proper equipment grounding practices at all ends of the interconnecting cables. In addition, it is recommended to use cable assemblies with overall shield solidly connected to the conductive shell of all connectors. Besides the beneficial effect of cable shielding on electromagnetic compatibility, the shield connection can increase the protection level against grounding problems in temporarily absorbing unwanted fault current.

Standard Compliance

Following notices apply to :

- **GRABLINK Value**
- **GRABLINK Avenue**
- **GRABLINK Expert 2**
- **GRABLINK Value cPCI**
- **GRABLINK Expert 2 cPCI**



Notice for USA

Compliance Information Statement (Declaration of Conformity Procedure) DoC FCC Part 15

This equipment has been tested and found to comply with the limits for a Class B digital device, pursuant to Part 15 of the FCC Rules.

These limits are designed to provide reasonable protection against harmful interference in a residential installation or when the equipment is operated in a commercial environment.

This equipment generates, uses and can radiate radio frequency energy and, if not installed and used in accordance with the instructions, may cause harmful interference to radio communications. However, there is no guarantee that interference will not occur in a particular installation.

If this equipment does cause harmful interference to radio or television reception, which can be determined by turning the equipment off and on, the user is encouraged to try to correct the interference by one or more of the following measures:

- Reorient or relocate the receiving antenna.
- Increase the separation between the equipment and receiver.
- Connect the equipment into an outlet on a circuit different from that to which the receiver is connected.
- Consult the dealer or an experienced radio/TV technician for help.



Notice for Europe

This product is in conformity with the Council Directive 89/336/EEC amended by 92/31/EEC and 93/68/EEC

This equipment has been tested and found to comply with EN55022/CISPR22 and EN55024/CISPR24. To meet EC requirements, shielded cables must be used to connect a peripheral to the card. This product has been tested in a typical class B compliant host system. It is assumed that this product will also achieve compliance in any class B compliant unit.

Camera Link Compliance

GRABLINK Value, GRABLINK Avenue and GRABLINK Value cPCI fully conform to the Base configuration as defined by the Camera Link Standard.

GRABLINK Expert 2 and GRABLINK Expert 2 cPCI fully conform to the Base and Medium configurations as defined by the Camera Link Standard.



GRABLINK Value Description

Product presentation

Grablink Value is an affordable Camera Link frame grabber for cost-effective industrial applications. Grablink Value is recommended for single-camera systems. It acquires images at a maximum camera speed of 60 MHz over the data path towards the on-board memory.

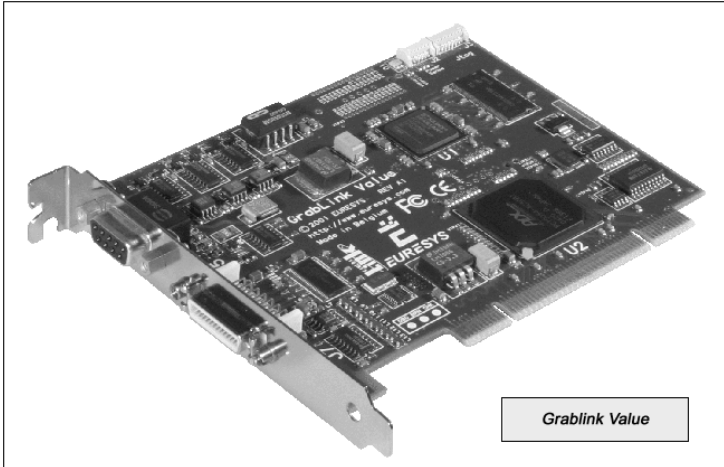

Block diagram

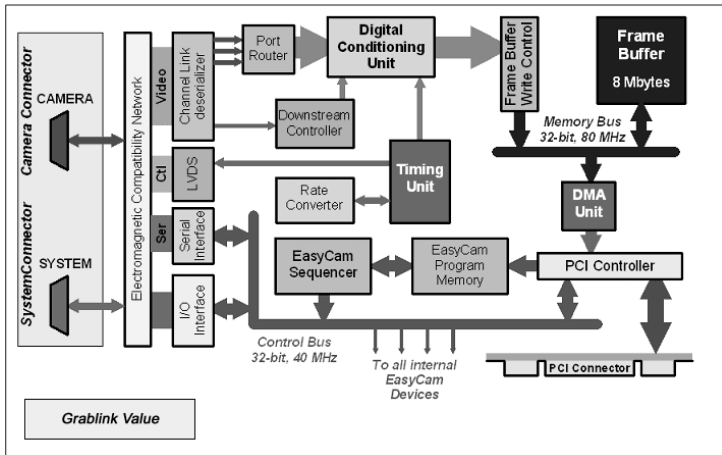

Board layout

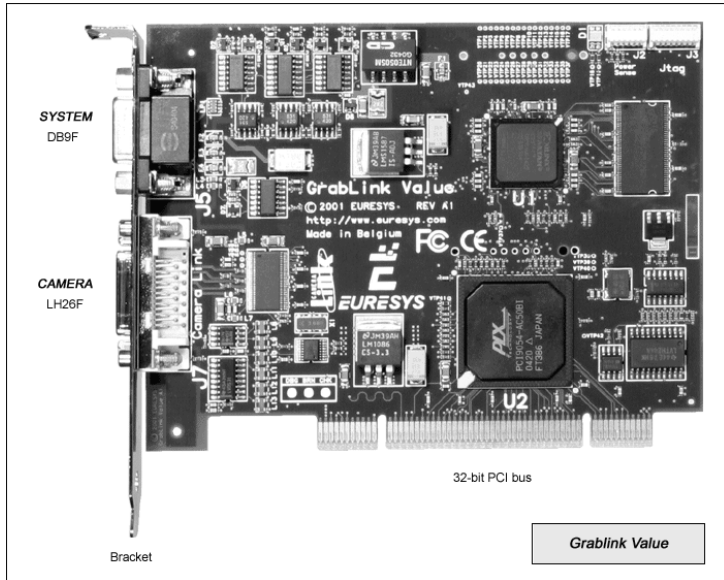

Bracket layout

The bracket attached to Grablink Value provides two connectors.

The upper connector is for system connection, such as external trigger, illumination control or motion encoder. It is a sub-D 9-pin female connector. This connector is called *SYSTEM*.

The lower connector is for camera connection. It is a blade contact high-density 26-pin female connector. It complies with the Camera Link standard. Grablink Value fully supports the Base configuration as per the standard. This connector is called *CAMERA*.

In depth information is available in the electronic documentation coming with Euresys products. Grablink manuals are parts of Euresys MultiCam documentation.

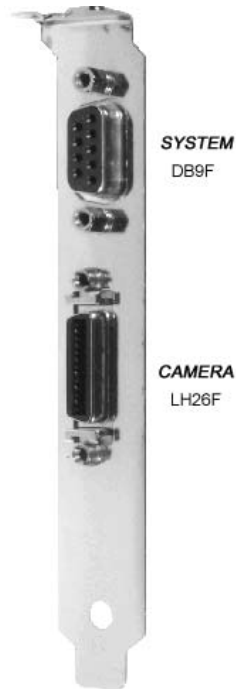

Camera connector

Grablink Value offers an on-board high-density 26-pin female sub-D connector named *CAMERA* for camera connection.

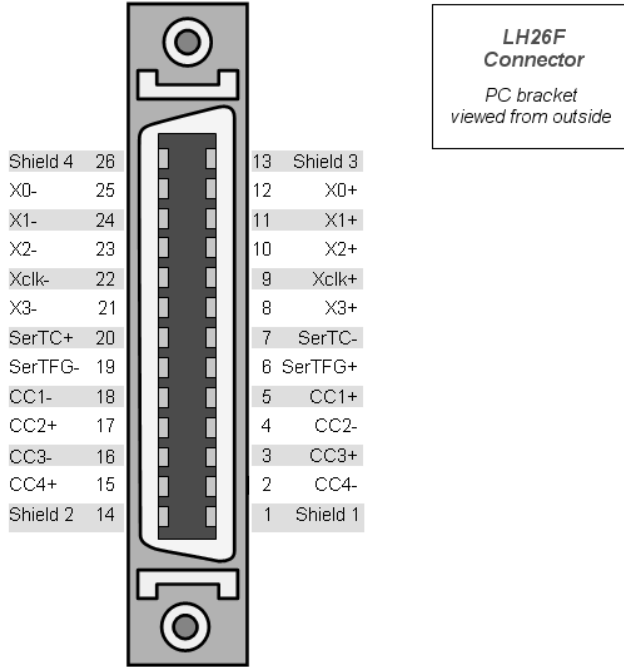

In depth information is available in the electronic documentation coming with Euresys products. Grablink manuals are parts of Euresys MultiCam documentation.

System connector

Grablink Value provides an on-board 9-pin female sub-D connector named *SYSTEM* for system connection, including opto-isolated trigger and strobe lines.

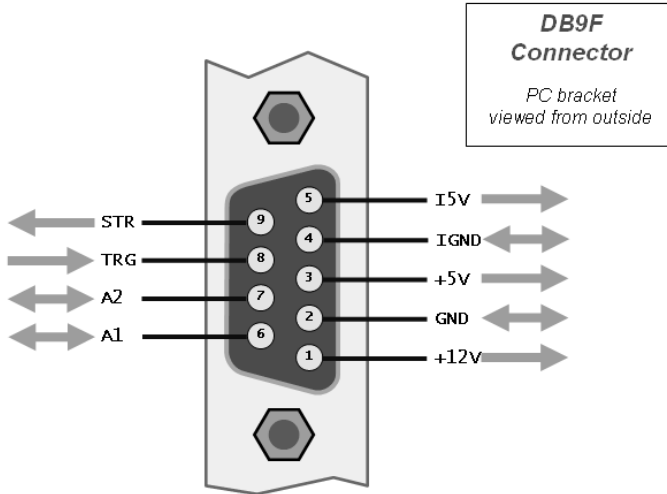

Installing interconnection cables to this connector is highly system dependent.

In depth information is available in the electronic documentation coming with Euresys products. Grablink manuals are parts of Euresys MultiCam documentation.

PCI requirements

PCI stands for "Peripheral Component Interconnect" and refers to standardized means to install an add-on board inside a computer.

Grablink Value is a short-size PCI card to be inserted in a standard PCI slot inside a PC. The PCI edge connector is compliant with the official PCI specification, revision 2.2. It is 32-bit wide, operates at 33 MHz maximum and supports both 3.3 V and 5 V signaling systems.

Grablink Value can be used in a 33 MHz or 66 MHz PCI slot like in a 66 MHz, 100 MHz or 133 MHz PCI-X slot. Installing the board on a 66 MHz or faster bus will restrict the bus to conventional PCI at 33 MHz for all PCI agents installed on this bus.

For more information about PCI and PCI-X, refer to the Euresys application note entitled "PCI Bus Variation".

Grablink Value uses the +5 V and +12 V power supply rails provided by the PCI bus. The +12 V supply is only provided to outside devices through the *SYSTEM* connector. The power consumption on this rail is therefore user dependent and is protected by a 0.5 A circuit breaker with automatic reset. On the *SYSTEM* connector, a positive 5 V voltage is also borrowed from the PC supply. A circuit breaker of 1 A with automatic reset protects the 5 V power supply. An isolated +5 V supply delivering 150 mA maximum is available.

GRABLINK Avenue Description

Product presentation

Grablink Avenue is an ultra-fast PCI frame grabber for line-scan or area-scan digital Camera Link cameras. It is ideal for industrial applications such as high-speed moving objects, web inspection or high-resolution acquisition.

Grablink Avenue is a high-performance 64-bit, 66 MHz PCI bus board acquiring images from one camera in the Camera Link Base configuration. This board acquires the 24-bit data, with any tap structure, at the maximum speed of 85 MHz.

With line-scan cameras, Grablink Avenue guarantees a constant sensitivity of the image regardless of the web speed variation, thanks to ADR*, a unique patented downweb resampler. Grablink Avenue is equipped with various I/O lines.

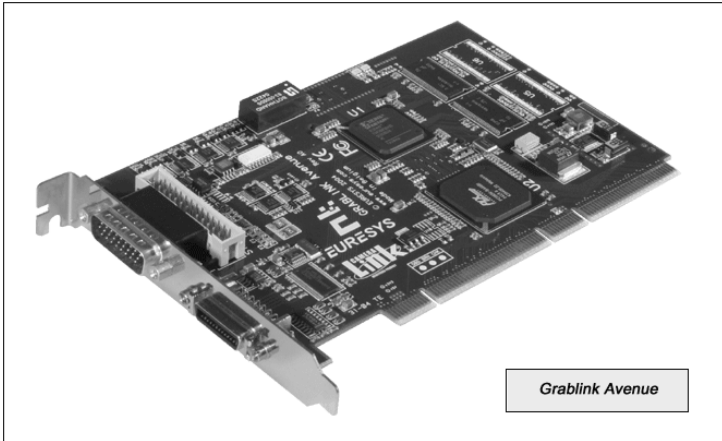

* Patent pending

Block diagram

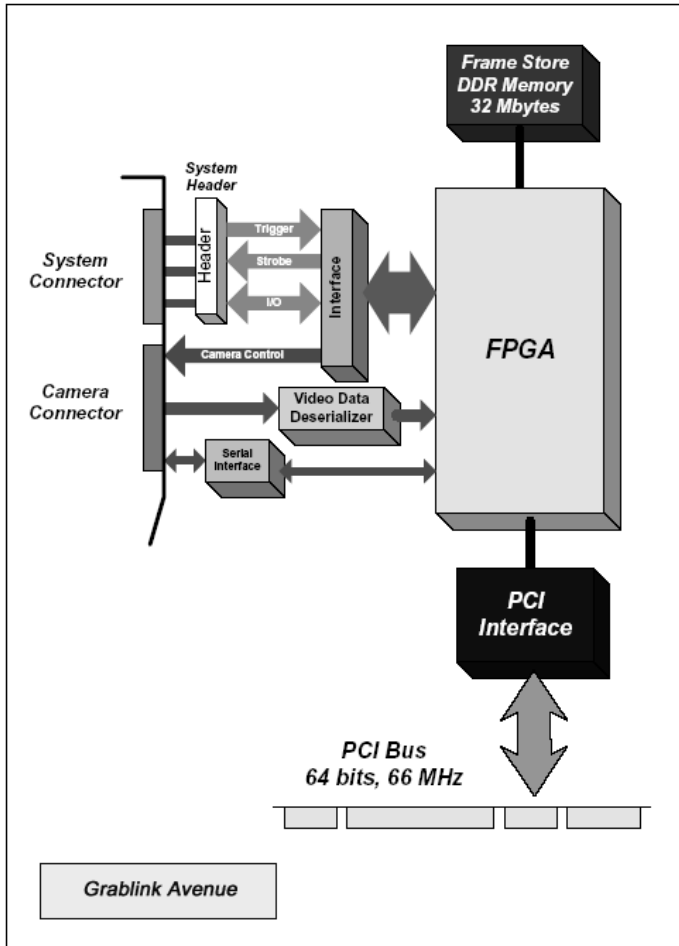

Board layout

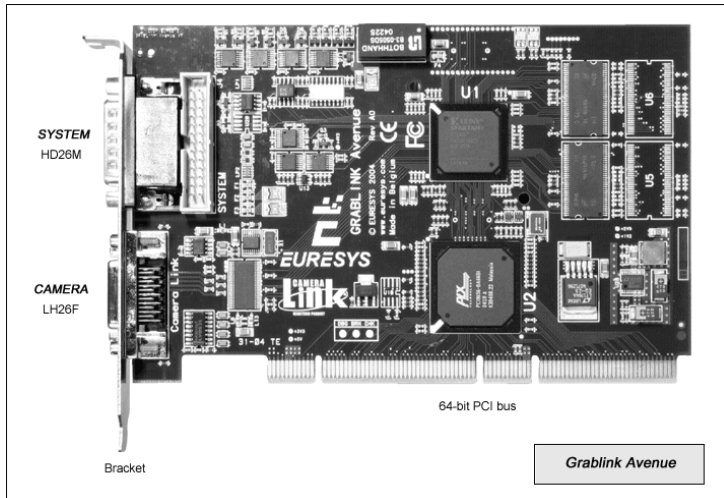

Bracket layout

The bracket attached to Grablink Avenue provides two connectors.

The upper connector is for system connection, such as external trigger, illumination control or motion encoder. It is a high density 26-pin connector. This connector is called *SYSTEM*.

The lower connector is for camera connection. It is a blade contact high-density 26-pin female connector. It complies with the Camera Link standard. Grablink Avenue fully supports the Base configuration as per the standard. This connector is called *CAMERA*.

In depth information is available in the electronic documentation coming with Euresys products. Grablink manuals are parts of Euresys MultiCam documentation.



Camera connector

Grablink Avenue offers an on-board high-density 26-pin female sub-D connector named *CAMERA* for camera connection.

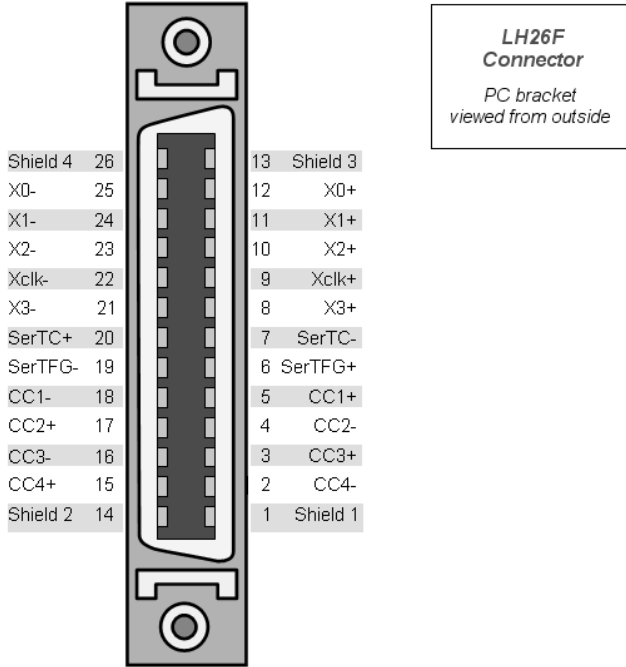

In depth information is available in the electronic documentation coming with Euresys products. Grablink manuals are parts of Euresys MultiCam documentation.

System connectors

External system connector

Grablink Avenue provides an on-board 26-pin connector named *SYSTEM* for system connection, including opto-isolated trigger and strobe lines.

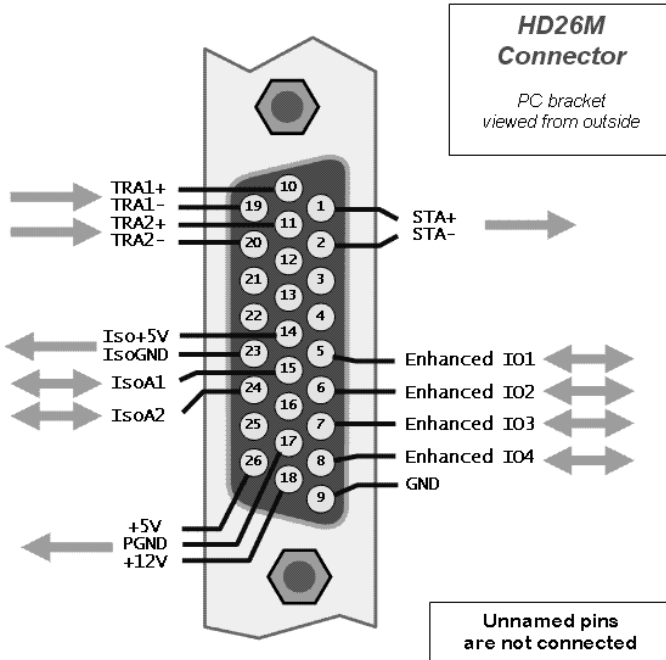

Installing interconnection cables to this connector is highly system dependent.

Internal system connector

Grablink Avenue also provides an internal 26-pin connector for system connections.

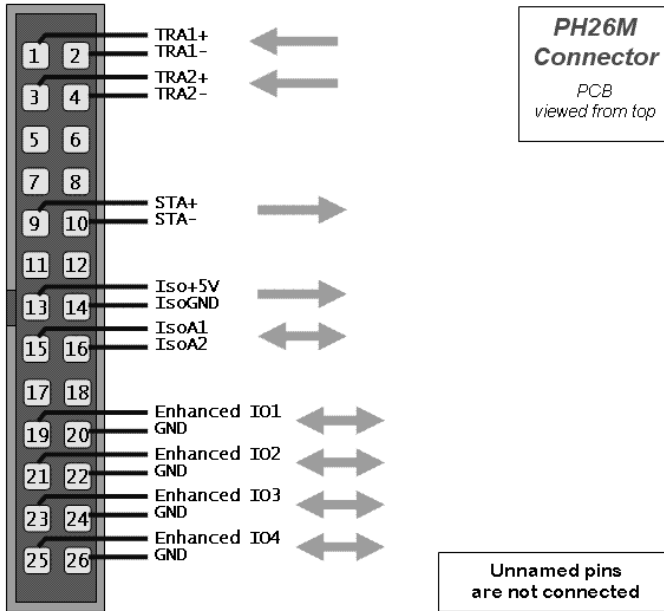

In depth information is available in the electronic documentation coming with Euresys products. Grablink manuals are parts of Euresys MultiCam documentation.

PCI requirements

PCI stands for "Peripheral Component Interconnect" and refers to standardized means to install an add-on board inside a computer.

Grablink Avenue is a short-size PCI card to be inserted in a standard PCI slot inside a PC. The PCI edge connector is compliant with the official PCI specification, revision 2.2. It is 64-bit wide, operates at 66 MHz maximum and supports both 3.3 V and 5 V signaling systems.

Grablink Avenue can be used in a 33 MHz or 66 MHz PCI slot like in a 66 MHz, 100 MHz or 133 MHz PCI-X slot. Installing the board on a PCI-X bus will restrict the bus to conventional PCI at 66 MHz for all PCI agents installed on this bus.

For more information about PCI and PCI-X, refer to the Euresys application note entitled "PCI Bus Variation".

Grablink Avenue uses the +5 V and +12 V power supply rails provided by the PCI bus. The +12 V supply is only provided to outside devices through the *SYSTEM* connector. The power consumption on this rail is therefore user dependent and is protected by a 0.5 A circuit breaker with automatic reset. On the *SYSTEM* connector, a positive 5 V voltage is also borrowed from the PC supply. A circuit breaker of 1 A with automatic reset protects the 5 V power supply. An isolated +5 V supply delivering 200 mA maximum is available.

GRABLINK Expert 2 Description

Product presentation

Grablink Expert 2 is a Camera Link frame grabber for demanding industrial applications. Supporting the Base or Medium configurations, it can be connected to one or two cameras. Grablink Expert 2 is a 64-bit, 66 MHz PCI bus frame grabber. Each camera delivers images at a maximum speed of 66 MHz over the data paths towards the on-board memory.

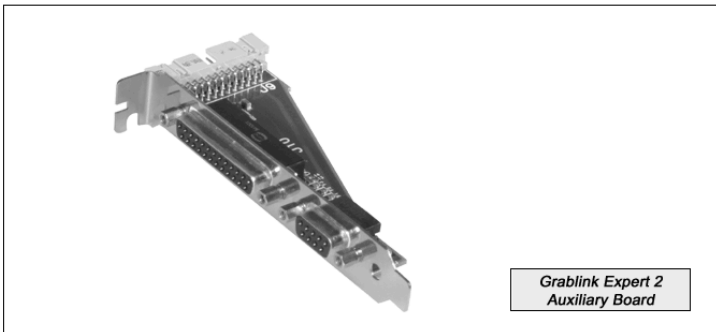
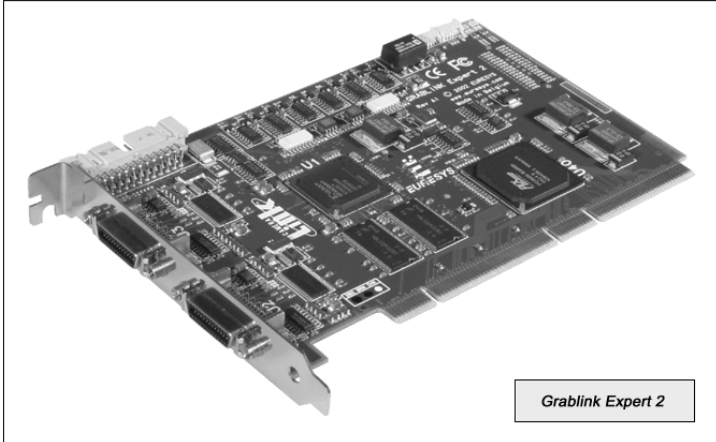

Block diagram

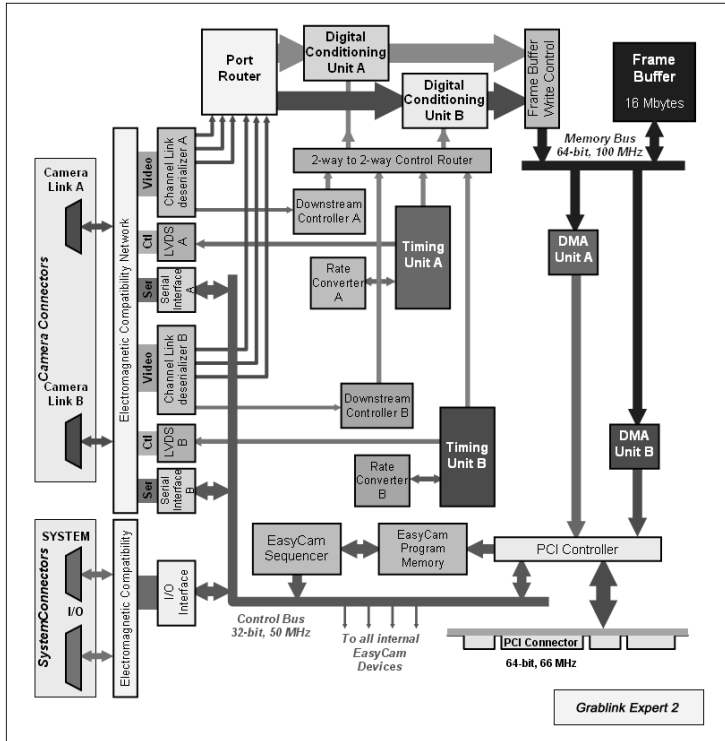

Board layout

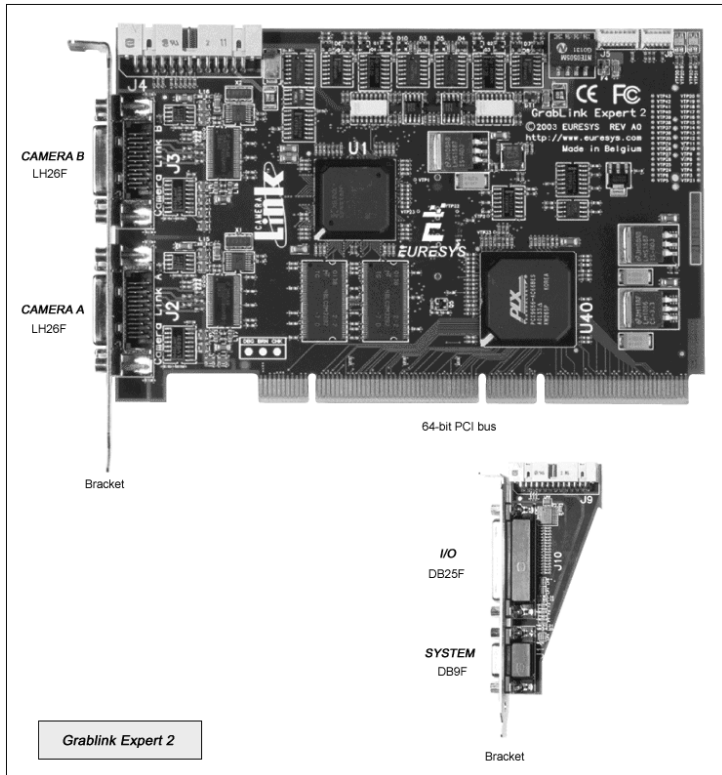

Bracket layout

The interconnection structure of Grablink Expert 2 uses two brackets.

The bracket attached to Grablink Expert 2 provides two connectors. They are both for camera connection. They are blade contact high-density 26-pin female connectors. They comply with the Camera Link standard.

The upper connector is called *CAMERA B*, while the lower one is called *CAMERA A*.

Grablink Expert 2 fully supports the Base and Medium configurations as per the standard. Refer to the following table:

Connector	Base configuration	Medium configuration	
Camera A	Used by first camera	Used by single camera	Primary
Camera B	Used by second camera		Secondary

Additional interconnection means are provided on a separate card bracket. It is attached to an auxiliary board linked to Grablink Expert 2 by a 26-wire ribbon cable.

The auxiliary bracket provides two connectors. The upper connector is for general purpose Input/Output connection. It is a sub-D 25-pin female connector. It is called *I/O*.

The lower connector is for system connection, such as external trigger, illumination control or motion encoder. It is a sub-D 9-pin female connector.

This connector is called *SYSTEM*.

In depth information is available in the electronic documentation coming with Euresys products. Grablink manuals are parts of Euresys MultiCam documentation.

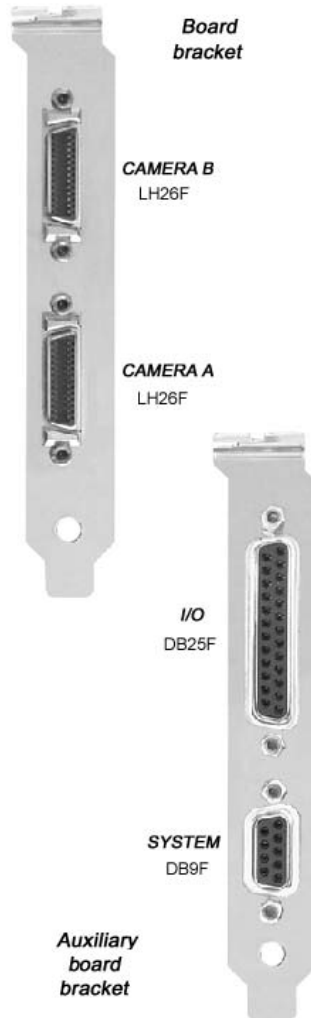

Camera connectors

Grablink Expert 2 offers two on-board high-density 26-pin female sub-D connector for camera connection. They are named *CAMERA A* and *CAMERA B*.

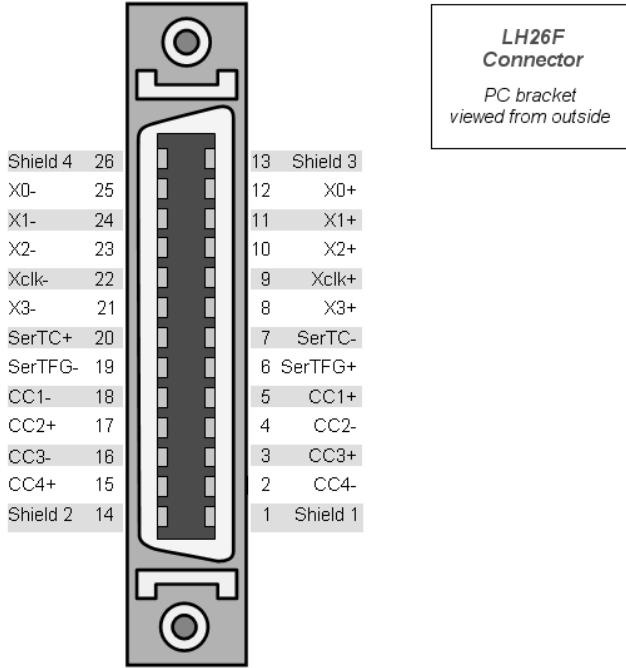

In depth information is available in the electronic documentation coming with Euresys products. Grablink manuals are parts of Euresys MultiCam documentation.

System connectors

Grablink Expert 2 provides two system connectors on a separate card bracket:

- A 9-pin female sub-D connector named *SYSTEM* for system connection, including opto-isolated trigger and strobe lines.
- A 25-pin female sub-D connector named *I/O* for general purpose Input/Output connection.

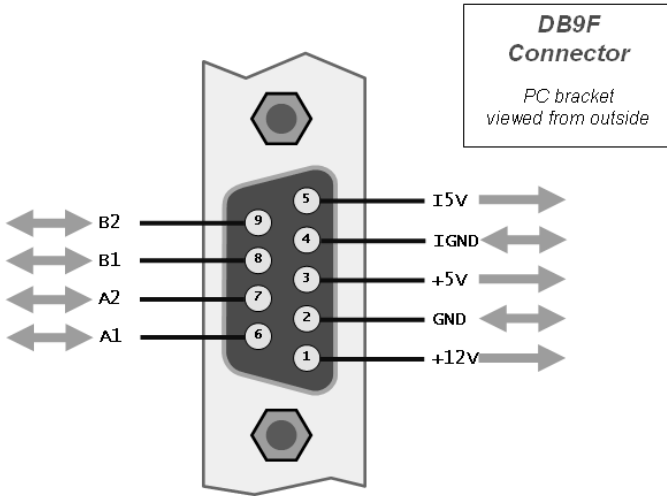

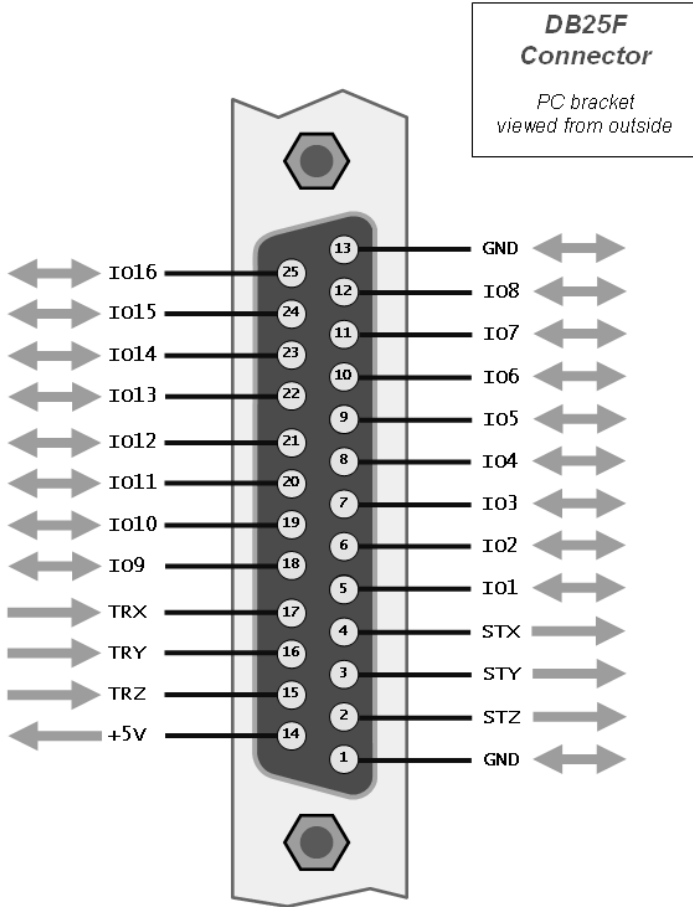

Installing interconnection cables to this connector is highly system dependent.

In depth information is available in the electronic documentation coming with Euresys products. Grablink manuals are parts of Euresys MultiCam documentation.

PCI requirements

PCI stands for "Peripheral Component Interconnect" and refers to standardized means to install an add-on board inside a computer.

Grablink Expert 2 is a medium-size PCI card to be inserted in a standard PCI slot inside a PC. The PCI edge connector is compliant with the official PCI specification, revision 2.2. It is 64-bit wide, operates at 66 MHz maximum and supports both 3.3 V or 5 V signaling systems.

Grablink Expert 2 can be used in a 33 MHz or 66-MHz PCI slot like in a 66 MHz, 100 MHz or 133 MHz PCI-X slot. Installing the board on a PCI-X bus will restrict the bus to conventional PCI at 66 MHz for all PCI agents installed on this bus.

For more information about PCI and PCI-X, refer to the Euresys application note entitled "PCI Bus Variation".

Grablink Expert 2 uses the +5 V and +12 V power supply rails provided by the PCI bus. The +12 V supply is only provided to outside devices through the *SYSTEM* connector. The power consumption on this rail is therefore user dependent and is protected by a 0.5 A circuit breaker with automatic reset. On the *SYSTEM* connector, a positive 5 V voltage is also borrowed from the PC supply. A circuit breaker of 1 A with automatic reset protects the 5 V power supply. An isolated +5 V supply delivering 200 mA maximum is available.

GRABLINK Value cPCI Description

Product presentation

Grablink Value cPCI is an affordable Camera Link frame grabber for cost-effective industrial applications. Grablink Value cPCI is recommended for single-camera systems. It acquires images at a maximum camera speed of 60 MHz over the data path towards the on-board memory.

Grablink Value cPCI is a 6U, 4HP CompactPCI card to be inserted in a standard CompactPCI slot inside an industrial PC.

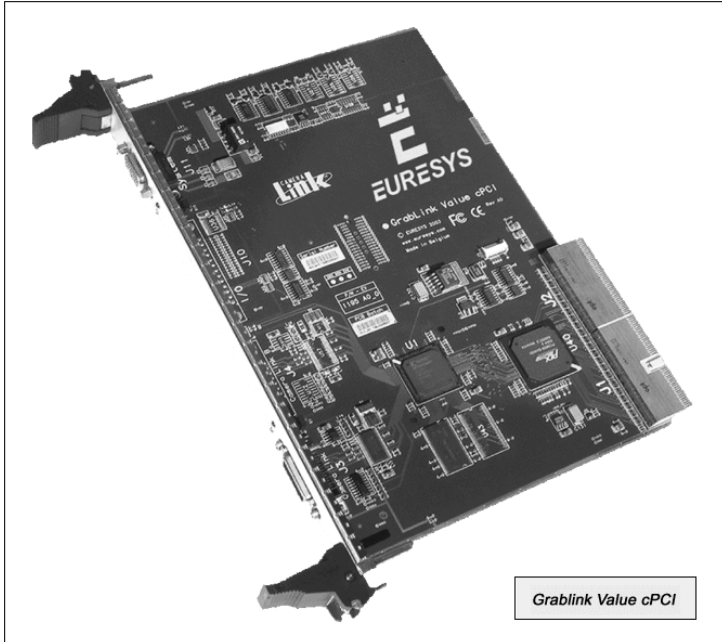

Grablink Value cPCI versus Grablink Value

Grablink Value cPCI and Grablink Value have basically identical characteristics. The physical dimensions of the respective boards are obviously different. The standard 32-bit, 33 MHz PCI connector of Grablink Value is replaced by a 64-bit, 66 MHz CompactPCI connector on Grablink Value cPCI. Other connectors are identical. Four LEDs are present only on Grablink Value cPCI. Their meaning is explained in the bracket description chapter (see following pages). All other characteristics are identical.

Block diagram

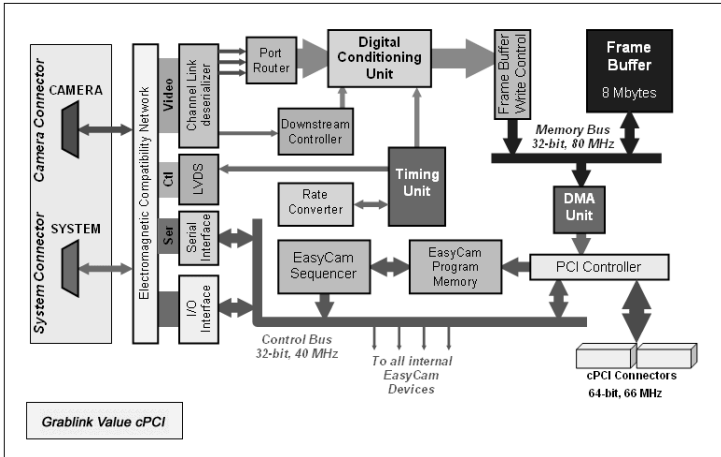

Board layout

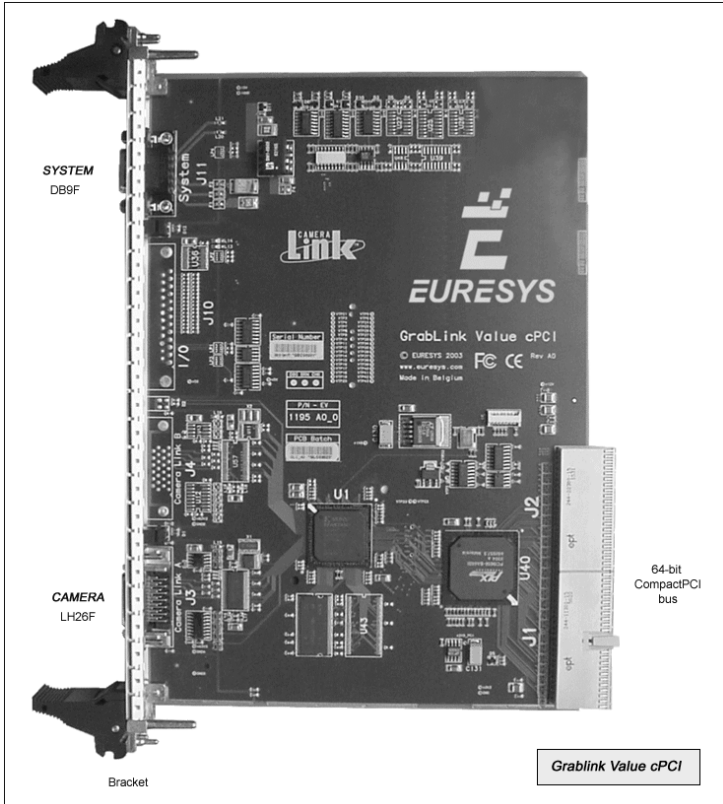

Bracket layout

The bracket attached to Grablink Value cPCI provides two connectors.

The upper connector is for system connection, such as external trigger, illumination control or motion encoder. It is a sub-D 9-pin female connector. This connector is called *SYSTEM*.

A red/green pair of LEDs called *Status LEDs* shows the global status of the frame grabber. When the green LED is lighting (ON), MultiCam is correctly started. If the red LED is lighting (ON), that is a board-wide error has appeared.

A second red/green pair of LEDs called *LEDs for CAMERA* gives information about each camera acquisition. The green LED is lighting (ON) during expose and readout phases of a sequence. If the red LED is lighting (ON), that is a channel acquisition error has appeared during the sequence.

The lower connector is for camera connection. It is a blade contact high-density 26-pin female connector. It complies with the Camera Link standard. Grablink Value cPCI fully supports the Base configuration as per the standard. This connector is called *CAMERA*.

In depth information is available in the electronic documentation coming with Euresys products. Grablink manuals are parts of Euresys MultiCam documentation.



Camera connector

Grablink Value cPCI offers an on-board high-density 26-pin female sub-D connector named *CAMERA* for camera connection.

This connector is identical to the camera connector of Grablink Value.

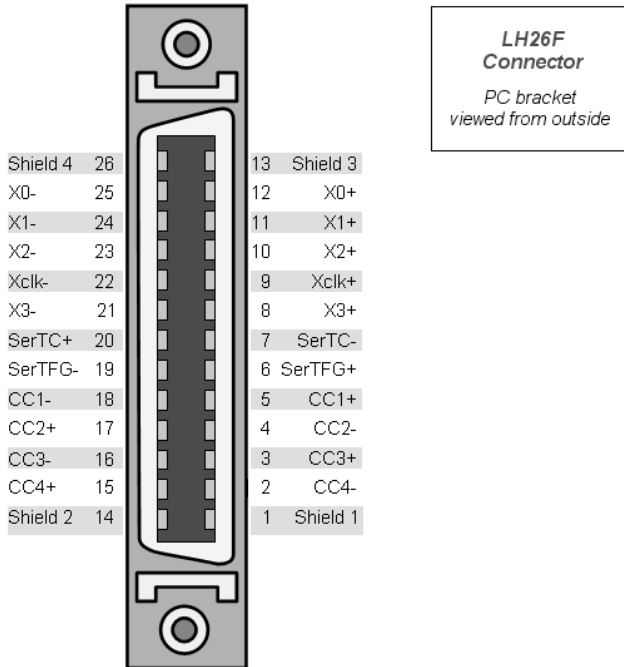

In depth information is available in the electronic documentation coming with Euresys products. Grablink manuals are parts of Euresys MultiCam documentation.

System connector

Grablink Value cPCI provides an on-board 9-pin female sub-D connector named *SYSTEM* for system connection, including opto-isolated trigger and strobe lines. This connector is identical to the system connector of Grablink Value.

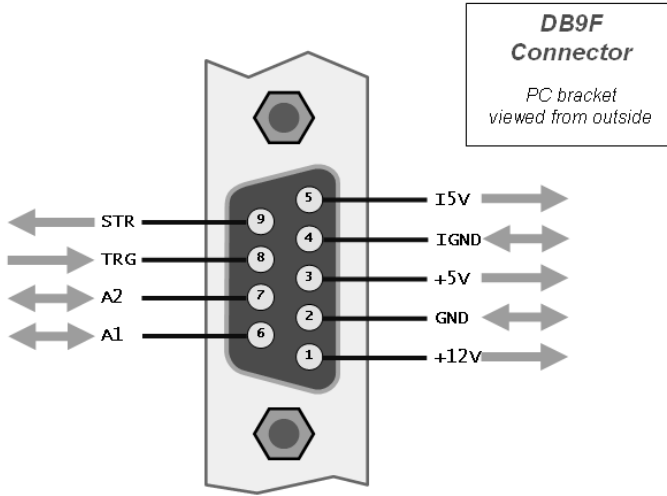

Installing interconnection cables to this connector is highly system dependent.

In depth information is available in the electronic documentation coming with Euresys products. Grablink manuals are parts of Euresys MultiCam documentation.

PCI requirements

PCI stands for "Peripheral Component Interconnect" and refers to standardized means to install an add-on board inside a computer.

Grablink Value cPCI is a 6U, 4HP CompactPCI card to be inserted in a standard CompactPCI slot inside an industrial PC. The CompactPCI connector is compliant with the official CompactPCI specification PICMG 2.0 R3.0 dated October 1, 1999. It is 64-bit wide, operates at 66 MHz maximum and supports both 3.3 V and 5 V signaling systems.

Grablink Value cPCI can be used in a 33 MHz or 66 MHz CompactPCI slot and used in a CompactPCI slot with either 32-bit or 64-bit.

For more information about PCI and PCI-X, refer to the Euresys application note entitled "PCI Bus Variation".

Grablink Value cPCI uses the +3.3 V, +5 V and +12 V power supply rails provided by the CompactPCI bus. The +12 V supply is only provided to outside devices through the *SYSTEM* connector. The power consumption on this rail is therefore user dependent and is protected by a 0.5 A circuit breaker with automatic reset. On the *SYSTEM* connector, a positive 5 V voltage is also borrowed from the PC supply. A circuit breaker of 1 A with automatic reset protects the 5 V power supply. An isolated +5 V supply delivering 150 mA maximum is available.

GRABLINK Expert 2 cPCI Description

Product presentation

Grablink Expert 2 cPCI is a Camera Link frame grabber for demanding industrial applications. Supporting the Base or Medium configurations, it can be connected to one or two cameras. Grablink Expert 2 cPCI is a 64-bit, 66 MHz PCI bus frame grabber. Each camera delivers images at a maximum speed of 66 MHz over the data paths towards the on-board memory. Grablink Expert 2 cPCI is a 6U, 4HP CompactPCI card to be inserted in a standard CompactPCI slot inside an industrial PC.

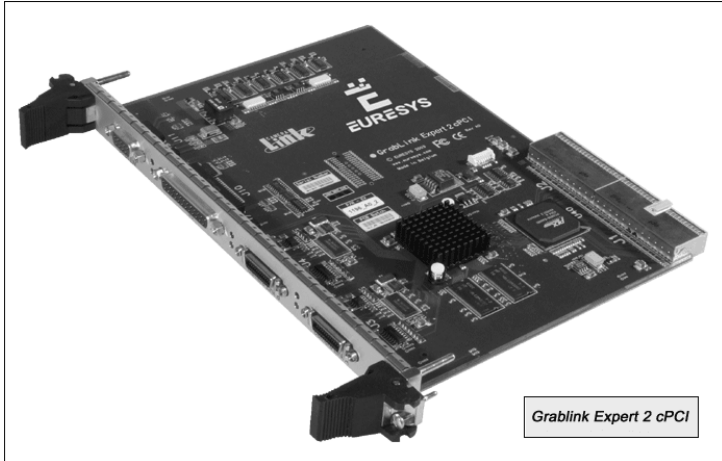

Grablink Expert 2 cPCI versus Grablink Expert 2

Grablink Expert 2 cPCI has basically the same characteristics than Grablink Expert 2 and its auxiliary board. The physical dimensions of the respective boards are obviously different. The standard 64-bit, 66 MHz PCI connector of Grablink Expert 2 is replaced by a 64-bit, 66 MHz CompactPCI connector on Grablink Expert 2 cPCI. Other connectors are identical. Therefore, Grablink Expert 2 cPCI includes I/O and SYSTEM connectors. Six LEDs are present only on Grablink Expert 2 cPCI. Their meaning is explained in the bracket description chapter (see following pages). All other characteristics are identical.

Block diagram

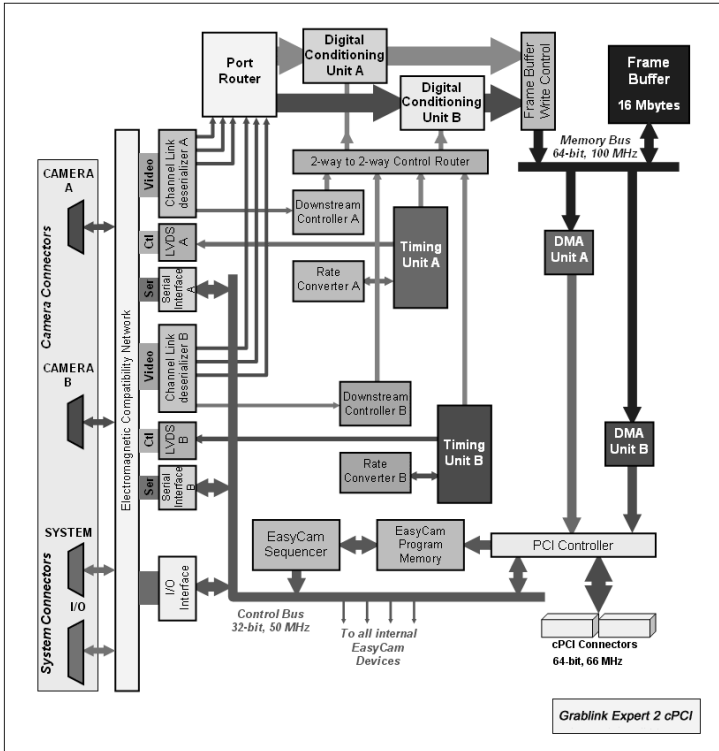

Board layout

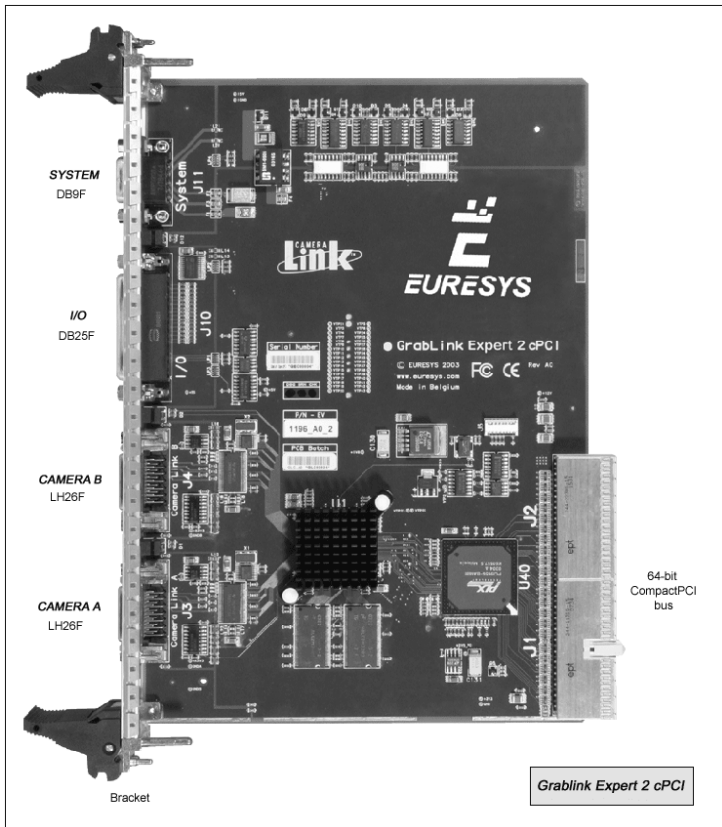

Bracket layout

The bracket attached to Grablink Expert 2 cPCI provides four connectors.

The upper connector is for system connection, such as external trigger, illumination control or motion encoder. It is a sub-D 9-pin female connector. This connector is called *SYSTEM*.

A red/green pair of LEDs called *Status LEDs* shows the global status of the frame grabber. When the green LED is lighting (ON), MultiCam is correctly started. If the red LED is lighting (ON), that is a board-wide error has appeared.

The second connector is for general purpose Input/Output connection. It is a sub-D 25-pin female connector. It is called *I/O*.

The two bottom connectors are for camera connection. They are blade contact high-density 26-pin female connectors. They comply with the Camera Link standard.

The upper connector is called *CAMERA B*, while the lower one is called *CAMERA A*.

Grablink Expert 2 cPCI fully supports the Base and Medium configurations as per the standard. Refer to the following table:

Connector	Base configuration	Medium configuration	
		Used by single camera	Primary
Camera A	Used by first camera	Used by single camera	Primary
Camera B	Used by second camera		Secondary

Two red/green pairs of LEDs called *LEDs for CAMERA B* and *LEDs for CAMERA A*, placed above the concerned connector, give information about each camera acquisition. The green LED is lighting (ON) during expose and readout phases of a sequence. If the red LED is lighting (ON), that is a channel acquisition error has appeared during the sequence.

In depth information is available in the electronic documentation coming with Euresys products. Grablink manuals are parts of Euresys MultiCam documentation.

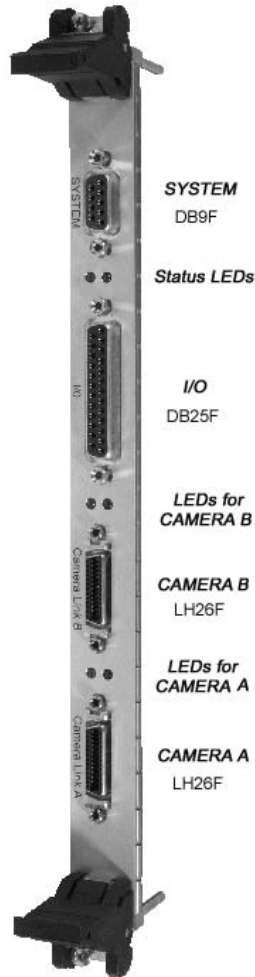

Camera connectors

Grablink Expert 2 cPCI offers two on-board high-density 26-pin female sub-D connector for camera connection. They are named *CAMERA A* and *CAMERA B*. These connectors are identical to the camera connectors of Grablink Expert 2.

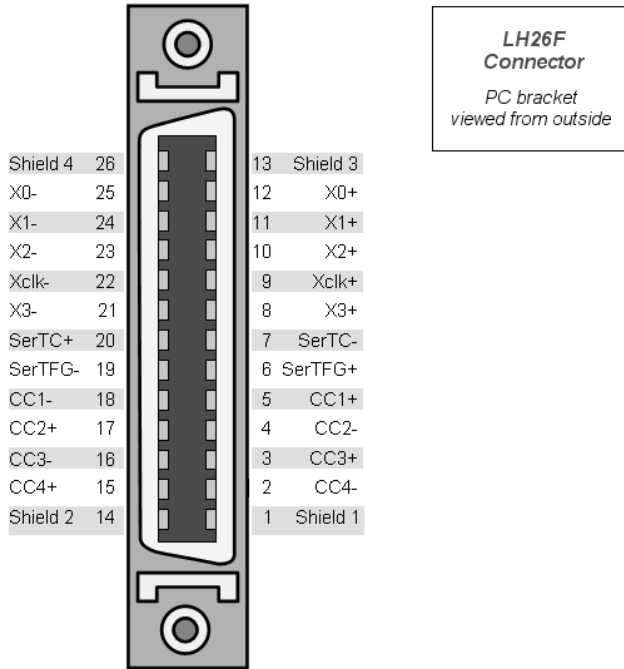

In depth information is available in the electronic documentation coming with Euresys products. Grablink manuals are parts of Euresys MultiCam documentation.

System connectors

Grablink Expert 2 cPCI provides two system connectors :

- A 9-pin female sub-D connector named *SYSTEM* for system connection, including opto-isolated trigger and strobe lines.
- A 25-pin female sub-D connector named *I/O* for general purpose Input/Output connection.

These connectors are identical to the system connectors of Grablink Expert 2.

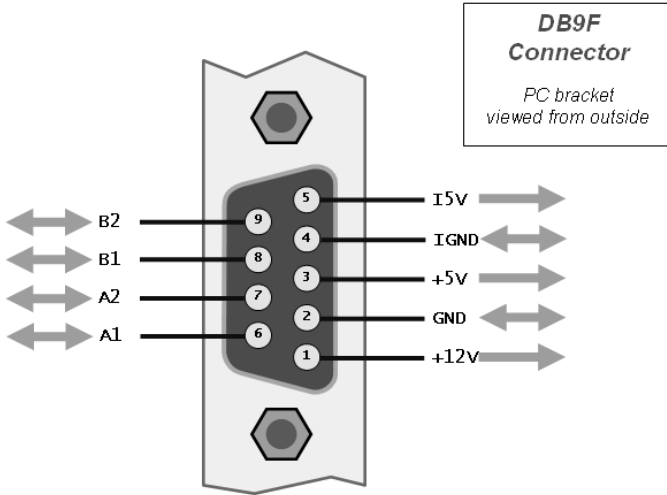

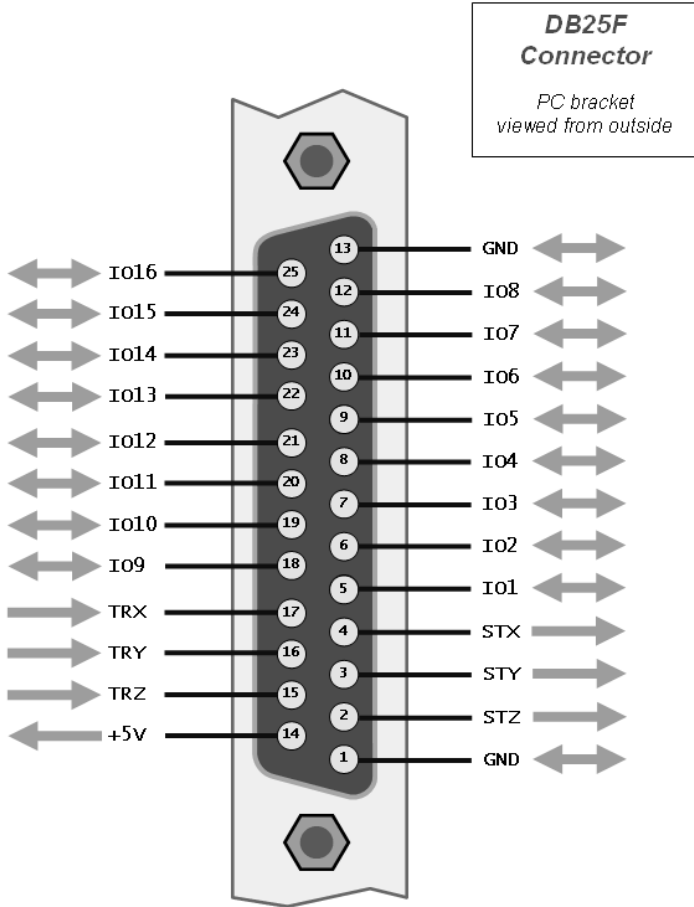

Installing interconnection cables to this connector is highly system dependent.

In depth information is available in the electronic documentation coming with Euresys products. Grablink manuals are parts of Euresys MultiCam documentation.

PCI requirements

PCI stands for "Peripheral Component Interconnect" and refers to standardized means to install an add-on board inside a computer.

Grablink Expert 2 cPCI is a 6U, 4HP CompactPCI card to be inserted in a standard CompactPCI slot inside an industrial PC. The CompactPCI connector is compliant with the official CompactPCI specification PICMG 2.0 R3.0 dated October 1, 1999. It is 64-bit wide, operates at 66 MHz maximum and supports both 3.3 V and 5 V signaling systems.

Grablink Expert 2 cPCI can be used in a 33 MHz or 66 MHz CompactPCI slot and used in a CompactPCI slot with either 32-bit or 64-bit.

For more information about PCI and PCI-X, refer to the Euresys application note entitled "PCI Bus Variation".

Grablink Expert 2 cPCI uses the +3.3 V, +5 V and +12 V power supply rails provided by the CompactPCI bus. The +12 V supply is only provided to outside devices through the *SYSTEM* connector. The power consumption on this rail is therefore user dependent and is protected by a 0.5 A circuit breaker with automatic reset. On the *SYSTEM* connector, a positive 5 V voltage is also borrowed from the PC supply. A circuit breaker of 1 A with automatic reset protects the 5 V power supply. An isolated +5 V supply delivering 200 mA maximum is available.

GRABLINK series Installation Instructions

Hardware installation procedure for Grablink Value, Grablink Avenue and Grablink Expert 2

Grablink Value, Grablink Avenue and Grablink Expert 2 are PCI add-on boards. Before operation, they must be physically inserted in an available PCI slot of your computer. Grablink Value, Grablink Avenue and Grablink Expert 2 need no hardware setup adjustment (switch or jumper). Multiple Euresys boards can be hosted in the same computer, as long as slots are available.

Recommended installation procedure:

1. Switch-off the computer and all connected peripherals (monitor, printer...).
2. Discharge any static electricity that could be accumulated on your body. You can achieve this by touching an unpainted metal part of the enclosure of your computer with a bare hand. Make sure that the computer is linked to the AC power outlet with proper earth connection.
3. Disconnect all cables from your computer, including AC power.
4. Open the computer enclosure to gain access to the PCI slots according to the manufacturer instructions.
5. Locate an available PCI slot and remove the blank bracket associated with this location. To achieve this, remove the securing screw and keep it aside for later use in the procedure. Keep the blank bracket in a known place for possible re-use.
6. Unwrap the Grablink packing, take the board and carefully hold it. Avoid any contact of the board with unnecessary items, including your clothes.
7. Gently insert the board in the targeted PCI slot, taking care to push it down fully into the slot. If you experience some resistance, remove the board and repeat the operation. You should attempt to make a perfect board-to-slot mechanical alignment for best results. Ensure that the lower part of the bracket is inserted into the corresponding enclosure fastening.
8. Secure the board with the saved screw.
9. For Grablink Expert 2, optionally install the auxiliary board (see following pages).
10. Close the computer enclosure according to the manufacturer instructions.
11. Establish the camera connection (see following pages).

Auxiliary board installation

Grablink Expert 2 comes with an auxiliary board that includes an additional card bracket. It provides highly convenient means for system connection not directly related to camera. Installing this board is optional.

The auxiliary board needs no hardware setup adjustment (switch or jumper).

The auxiliary board must be installed in a free PC bracket location, as depicted in the drawing, taking into account the length of the provided interconnecting ribbon cable.

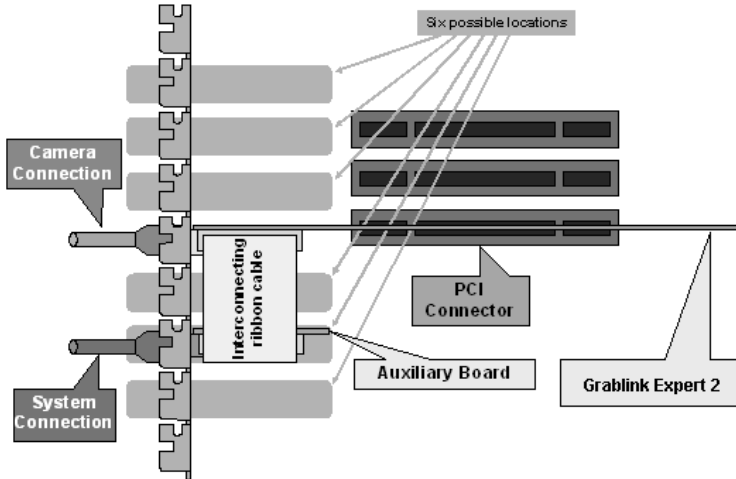

Note. Install the bracket after installing Grablink Expert 2, with the same precautions.

Auxiliary board recommended installation procedure:

1. Choose an available location and remove the associated blank bracket. To achieve this, remove the securing screw and keep it aside for later use in the procedure. Keep the blank bracket in a known place for possible re-use.
2. Place the auxiliary board in the targeted location. Ensure that the lower part of the bracket is inserting into the corresponding enclosure fastening.
3. Secure the auxiliary board with the saved screw.
4. Fasten the interconnecting ribbon cable on both sides. If necessary, bend this cable.

Hardware installation procedure for Grablink Value cPCI and Grablink Expert 2 cPCI

Grablink Value cPCI and Grablink Expert 2 cPCI are CompactPCI add-on boards. Before operation, they must be physically inserted in an available CompactPCI slot of the industrial PC. Multiple Euresys boards can be hosted in the same industrial PC, as long as slots are available.

Grablink Value cPCI and Grablink Expert 2 cPCI need no hardware setup adjustment (switch or jumper).

Recommended installation procedure:

1. Switch-off the industrial PC and all connected peripherals (monitor, printer...).
2. Discharge any static electricity that could be accumulated on your body. You can achieve this by touching an unpainted metal part of the enclosure of your industrial PC with a bare hand. Make sure that the industrial PC is linked to the AC power outlet with proper earth connection.
3. Locate an available CompactPCI slot and remove the blank front plate associated with this location. Keep the blank front plate in a known place for possible re-use.
4. Unwrap the Grablink packing, take the board and carefully hold it. Avoid any contact of the board with unnecessary items, including your clothes.
5. Prior to the installation of the board, disengage the insertion/extraction handles by first unlocking the handles and pressing them down.
6. Gently insert the board in the chosen CompactPCI slot and, using the insertion/extraction handles, ensure that it is properly seated in the backplane. The front panel should be flush with the rack front and the insertion/extraction handles should be locked.
7. Fasten the front panel retaining screws.
8. Establish the camera connection.

Recommended removal procedure:

1. Disconnect all cables that are connected to the board.
2. Loosen both of the front panel retaining screws.
3. Unlock the insertion/extraction handles.
4. Gently disengage the board from the backplane by pressing down on the insertion/extraction handles and pull the board out of the CompactPCI slot ensuring that the board does not make any contact with adjacent boards. If the insertion/extraction handles do not move, it is that they are not unlock; unlock them and try again.

Camera connection

Linking a camera to a Camera Link compliant frame grabber is very straightforward. Use a Camera Link compliant cable and connect each end to the camera and the frame grabber. Secure the connectors with provided screws.

Camera Link cable connectors are identical on both ends. The cable can be installed in either direction. However, the cable does not exhibit a pin-to-pin parallel connecting scheme.

The maximum cable length is system dependent. The cable performance as well as the transmission frequency may affect the maximum cable length. Refer to cable and camera characteristics. A cable length of 5 meters (16.4 feet) can be reached in all situations.

Power supply should be provided externally in full accordance with the camera manufacturer instructions.

In the Euresys proprietary cable designation system, the required cable is the following:

Cable Name	Cable Designation
CameraLink Standard	CL-C01-xx

"xx" is a two-digit number expressing the length of the cable in meters.

Always switch-off power to all pieces of equipment before connecting or disconnecting a camera cable. Failing to do so may result in damage to the board and/or to the camera.

Refer to the following drawings to clarify the camera connection structure according to the camera configuration.

Base configuration of Grablink Value, Grablink Avenue and Grablink Value cPCI

In accordance with the Camera Link standard, the Base configuration defines a camera linked to the frame grabber with one standard cable.

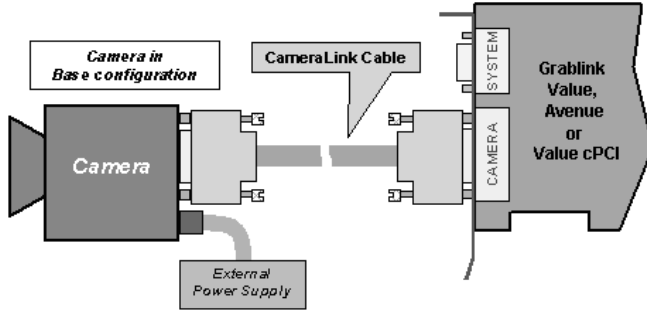

Base configurations of Grablink Expert 2 and Grablink Expert 2 cPCI

In accordance with the Camera Link standard, the Base configuration defines a camera linked to the frame grabber with one standard cable.

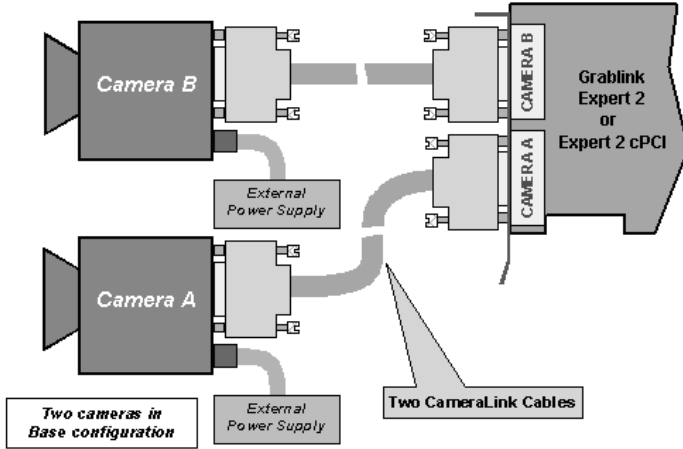

In this case, the Grablink Expert 2 board operates in the DuoCam mode, as two cameras are handled simultaneously and independently.

Medium configuration of Grablink Expert 2 and Grablink Expert 2 cPCI

In accordance with the Camera Link standard, the Medium configuration defines a camera linked to the frame grabber with two standard cables.

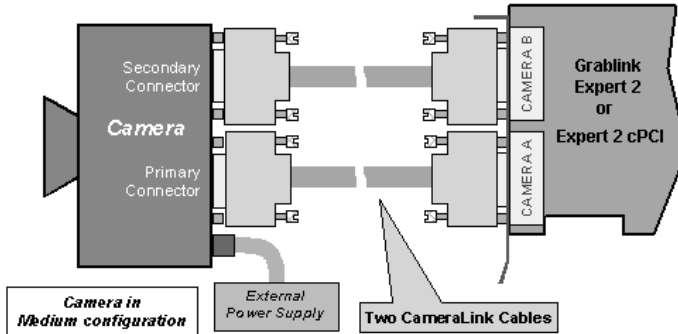

In this case, Grablink Expert 2 and Grablink Expert 2 cPCI operate in the MonoCam mode, as only one camera is handled.

MultiCam Installation Instructions

Hardware requirements

Following features are recommended to operate MultiCam:	
CPU	Pentium III Class or above
System memory	Minimum 128 MB
Hard disk drive	Minimum 150 MB free

Windows installation

Software requirements

MultiCam and Grablink boards can be operated on the following Microsoft Windows operating systems.

OS version	Additional information
Windows Server 2003	-
Windows XP Embedded	-
Windows XP	-
Windows 2000	Service Pack 2 or later

The development tools are C, C++, ActiveX and .NET* based. Thus all popular development environments can be used to develop applications using Grablink boards and MultiCam. Moreover, sample programs are provided for various development environments.

* Check the electronic documentation for details.

IDE version
In depth information about the supported development environment versions is available in the electronic documentation coming with Euresys products.

The electronic documentation coming with Euresys products is provided in Microsoft standard CHM format. Additional information can be provided as Adobe Acrobat PDF files.

Utilities	File format
Internet Explorer 4 or later *	For CHM files.
Adobe Acrobat Reader 4 or later *	For PDF files.

* For your convenience, a version is provided on most Euresys CD-ROM.

Installation instructions

1. Switch-on your computer and start Windows. Log in with administrative rights.
2. If a Grablink board was newly added in the system, Windows "Hardware Installation Wizard" will detect the board and possibly prompt for user action. Don't care about this wizard.

3. Place Euresys CD-ROM in the drive. The setup application starts automatically. If this is not the case, run 'setup.exe' directly from the CD-ROM.
4. Select the option to install MultiCam.
5. Depending on the operating system, the installation procedure may differ. Follow carefully the setup program instructions.
6. Check for proper installation: connect a camera to the Grablink board and run *eVision Evaluator*.

Linux installation

Software requirements

MultiCam and Grablink boards can be operated on the following Linux operating systems.

OS version	Additional information
RedHat 7.3	Kernel 2.4.18-3
RedHat 8.0	Kernel 2.4.18-14

The development tools are C or C++ based. Thus all popular development environments can be used to develop applications using Grablink boards and MultiCam. Moreover, sample programs are provided for various development environments.

IDE version
In depth information about the supported development environment versions is available in the electronic documentation coming with Euresys products.

The electronic documentation coming with Euresys products is provided in standard CHM format. Additional information can be provided as Adobe Acrobat PDF files.

Utilities	File format
xchm	For CHM files.
xpdf or Adobe Acrobat Reader 4 (or later)	For PDF files.

Installation instructions

1. Switch-on your computer and start Linux.
2. Place Euresys CD-ROM in the drive and mount it.
3. Copy `multicam-x.y.tar.gz` on hard disk drive where `x.y` is the release version of MultiCam.
Example: multicam-4.5.tar.gz
4. Extract the archive: `# tar -xzvf multicam-x.y.tar.gz`
5. Go into the MultiCam directory: `# cd multicam-x.y`
6. Log in as root.
7. Execute the installation script: `# ./install`
8. Check for proper installation: connect a camera to the Grablink board and run *eVision Evaluator*.

Technical Specifications

Grablink Value technical specifications

Characteristics

Dimensions	132 mm x 103 mm
Power consumption	3.5 W
PCI capability	32-bit, 33 MHz, 3.3 V or 5 V signaling
Certification	FCC class B and CE
Video connections	1 Camera Link camera in Base configuration

Operating conditions

Parameter	Symbol	Min	Typ	Max	Units
Power supply +5V	V _{+5V}	4.75	5.00	5.25	V
Ambient operating temperature	T _A	0		50	°C
Relative humidity		10		90	%

TTL input/output characteristics

Parameter	Min	Max	Units
High level output voltage	4	5	V
High level output current		15	mA
Low level output voltage	0	600	mV
Low level output current		10	mA
Input current with TR _a = +5V, if configured in TTL input, high level (*)		±1	µA
Input current with TR _a = GND, if configured in TTL input, low level (*)		-1	mA

(*) The letter "a" is G, X, Y or Z.

Isolated input/output characteristics

Parameter	Min	Max	Units
High level output voltage	4.5	5.2	V
High level output current		8	mA
Low level output voltage	0	600	mV
Low level output current		100	mA
Input current if configured in 12V input, high level		5	mA
Input current if configured in 12V input, low level		50	mA
Input current if configured in TTL input, high level		200	mA
Input current if configured in TTL input, low level		2	mA

Power supply current requirements

Parameter		Fuse	Max	Units
Frame grabber consumption	Supply current for +5V		700	mA
Alimentation of outside devices	Supply current for +5V	1		A
	Supply current for isolated +5V	150		mA
	Supply current for +12V	500		mA

Grablink Avenue technical specifications

Characteristics

Dimensions	168 mm x 107 mm
Power consumption	tbd
PCI capability	64-bit, 66 MHz, 3.3 V or 5 V signaling
Certification	FCC class B and CE
Video connections	1 Camera Link camera in Base configuration

Operating conditions

Parameter	Symbol	Min	Typ	Max	Units
Power supply +5V	V_{+5V}	4.75	5.00	5.25	V
Ambient operating temperature	T_A	0		50	°C
Relative humidity		10		90	%

TTL input/output characteristics

Parameter	Min	Max	Units
High level output voltage	4	5	V
High level output current		15	mA
Low level output voltage	0	600	mV
Low level output current		10	mA
Input current with $TR_a = +5V$, if configured in TTL input, high level (*)		± 1	μA
Input current with $TR_a = GND$, if configured in TTL input, low level (*)		-1	mA

(*) The letter "a" is G, X, Y or Z.

Isolated input/output characteristics

Parameter	Min	Max	Units
High level output voltage	4.5	5.2	V
High level output current		8	mA
Low level output voltage	0	600	mV
Low level output current		100	mA
Input current if configured in 12V input, high level		5	mA
Input current if configured in 12V input, low level		50	mA
Input current if configured in TTL input, high level		200	mA
Input current if configured in TTL input, low level		2	mA

Power supply current requirements

Parameter		Fuse	Max	Units
Frame grabber consumption	Supply current for +5V		700	mA
Alimentation of outside devices	Supply current for +5V	1		A
	Supply current for isolated +5V	150		mA
	Supply current for +12V	500		mA

Grablink Expert 2 technical specifications

Characteristics

Dimensions	210 mm x 107 mm
Power consumption	6 W
PCI capability	64-bit, 66 MHz, 3.3 V or 5 V signaling
Certification	FCC class B and CE
Video connections	1 Camera Link camera in Medium configuration or 2 Camera Link cameras in Base configuration

The auxiliary board that can be connected to Grablink Expert 2 has following characteristics:

Auxiliary board	
Dimensions	32 mm x 107 mm
Power consumption	2 mW
Certification	FCC class B and CE

Operating conditions

Parameter	Symbol	Min	Typ	Max	Units
Power supply +5V	V_{+5V}	4.75	5.00	5.25	V
Ambient operating temperature	T_A	0		50	°C
Relative humidity		10		90	%

TTL input/output characteristics

Parameter	Min	Max	Units
High level output voltage	4	5	V
High level output current		15	mA
Low level output voltage	0	600	mV
Low level output current		10	mA
Input current with $TRa = +5V$ or IO_n , if configured in TTL input, high level (*)		± 1	μA
Input current with $TRa = GND$ or IO_n , if configured in TTL input, low level (*)		-1	mA

(*) The letter "a" is G, X, Y or Z; the letter "n" is 1 to 16.

Isolated input/output characteristics

Parameter	Min	Max	Units
High level output voltage	4.5	5.2	V
High level output current		8	mA
Low level output voltage	0	600	mV
Low level output current		100	mA
Input current if configured in 12V input, high level		5	mA
Input current if configured in 12V input, low level		50	mA
Input current if configured in TTL input, high level		200	mA
Input current if configured in TTL input, low level		2	mA

Power supply current requirements

Parameter		Fuse	Max	Units
Frame grabber consumption	Supply current for +5V		1.2	A
Alimentation of outside devices	Supply current for +5V	1		A
	Supply current for isolated +5V	150		mA
	Supply current for +12V	500		mA

Grablink Value cPCI technical specifications

Characteristics

Dimensions	160 mm x 233 mm
Power consumption	4 W
PCI capability	64-bit, 66 MHz, 3.3 V or 5 V signaling
Certification	FCC class B and CE
Video connections	1 Camera Link camera in Base configuration

Operating conditions

Parameter	Symbol	Min	Typ	Max	Units
Power supply +5V	V _{+5V}	4.75	5.00	5.25	V
Power supply +3.3V	V _{+3.3V}	3.15	3.30	3.45	V
Ambient operating temperature	T _A	0		50	°C
Relative humidity		10		90	%

TTL input/output characteristics

Parameter	Min	Max	Units
High level output voltage	4	5	V
High level output current		15	mA
Low level output voltage	0	600	mV
Low level output current		10	mA
Input current with TR _a = +5V, if configured in TTL input, high level (*)		±1	µA
Input current with TR _a = GND, if configured in TTL input, low level (*)		-1	mA

(*) The letter "a" is G, X, Y or Z.

Isolated input/output characteristics

Parameter	Min	Max	Units
High level output voltage	4.5	5.2	V
High level output current		8	mA
Low level output voltage	0	600	mV
Low level output current		100	mA
Input current if configured in 12V input, high level		5	mA
Input current if configured in 12V input, low level		50	mA
Input current if configured in TTL input, high level		200	mA
Input current if configured in TTL input, low level		2	mA

Power supply current requirements

Parameter		Fuse	Max	Units
Frame grabber consumption	Supply current for +5V		tbd	A
	Supply current for +3.3V		tbd	mA
Alimentation of outside devices	Supply current for +5V	1		A
	Supply current for isolated +5V	150		mA
	Supply current for +12V	500		mA

Grablink Expert 2 cPCI technical specifications

Characteristics

Dimensions	160 mm x 233 mm
Power consumption	7 W
PCI capability	64-bit, 66 MHz, 3.3 V or 5 V signaling
Certification	FCC class B and CE
Video connections	1 Camera Link camera in Medium configuration or 2 Camera Link cameras in Base configuration

Operating conditions

Parameter	Symbol	Min	Typ	Max	Units
Power supply +5V	V _{+5V}	4.75	5.00	5.25	V
Power supply +3.3V	V _{+3.3V}	3.15	3.30	3.45	V
Ambient operating temperature	T _A	0		50	°C
Relative humidity		10		90	%

TTL input/output characteristics

Parameter	Min	Max	Units
High level output voltage	4	5	V
High level output current		15	mA
Low level output voltage	0	600	mV
Low level output current		10	mA
Input current with TR _a = +5V or I _{On} , if configured in TTL input, high level (*)		±1	µA
Input current with TR _a = GND or I _{On} , if configured in TTL input, low level (*)		-1	mA

(*) The letter "a" is G, X, Y or Z; the letter "n" is 1 to 16.

Isolated input/output characteristics

Parameter	Min	Max	Units
High level output voltage	4.5	5.2	V
High level output current		8	mA
Low level output voltage	0	600	mV
Low level output current		100	mA
Input current if configured in 12V input, high level		5	mA
Input current if configured in 12V input, low level		50	mA
Input current if configured in TTL input, high level		200	mA
Input current if configured in TTL input, low level		2	mA

Power supply current requirements

Parameter		Fuse	Max	Units
Frame grabber consumption	Supply current for +5V		tbd	A
	Supply current for +3.3V		tbd	mA
Alimentation of outside devices	Supply current for +5V	1		A
	Supply current for isolated +5V	150		mA
	Supply current for +12V	500		mA