

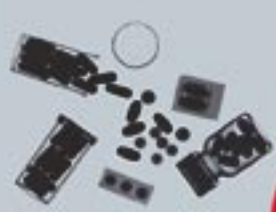

EureCard™ PICOLO™ series

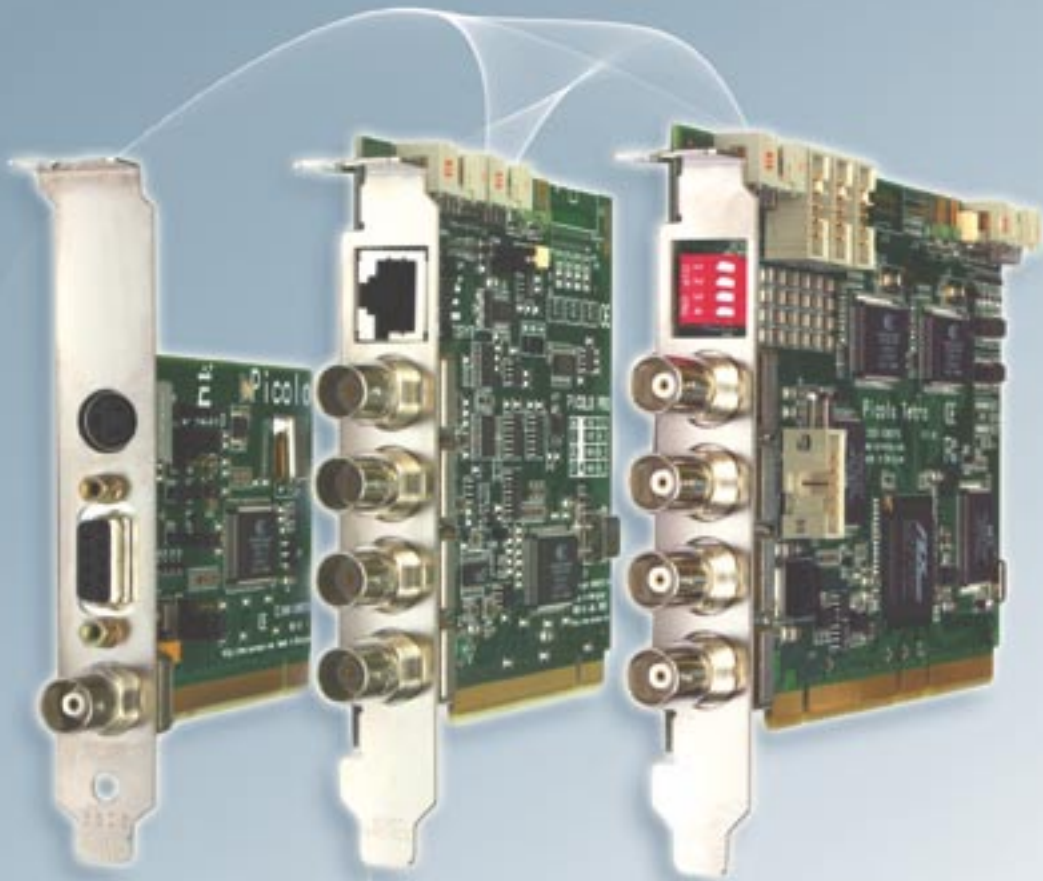

High-quality video capture boards



PICOLO™ – PICOLO Pro 2™
PICOLO Pro 3™ – PICOLO Tetra™

www.euresys.com
info@euresys.com

© Copyright 2005 Euresys s.a. Belgium. Euresys® and EureCard® are registered trademarks of Euresys s.a. Belgium. Other product and company names listed are trademarks or trade names of their respective manufacturers. Euresys reserves the right to modify product specifications and price without previous notice.



EURESYS™
Excellence in vision

EureCard™ PICOLO™ series

The **Piccolo series** are PCI video capture boards with an **outstanding price/quality ratio**. They are featured for standard composite video acquisition in color (**PAL, NTSC**) or in monochrome format (**CCIR, EIA**).

The Piccolo boards support the acquisition of **full resolution** images (640 x 480 or 768 x 576). Individual frames as well as video sequences are captured directly to the PC memory. Any image format is supported thanks to a **high-quality hardware scaler**. Arbitrary cropping to a region of interest is built-in. The Piccolo series generate bitmaps in all **popular color formats** such as RGB, YUV, planar or packed.

The Piccolo series video capture boards are designed to drastically simplify the design of video surveillance applications.

They come with the **MultiCam driver** and are compatible with **eVision**, the image analysis tools from Euresys. eVision offers C++ and ActiveX tools to read and record sequences of images using AVI files. System integrators benefit from robust and easy-to-use **standard connectors**.

- **Low-cost, high-quality**
- **Full-frame real-time acquisition from 1 to 4 cameras**
- **Quick switching acquisition up to 16 cameras**
- **Color PAL/NTSC, monochrome CCIR/EIA**
- **Video surveillance and industrial applications**

	<i>PICOLO</i>	<i>PICOLO Pro 2</i>	<i>PICOLO Pro 3</i>	<i>PICOLO Tetra</i>
Form factor	PCI	PCI	PCI	PCI
Standard	PAL / NTSC CCIR / RS170	PAL / NTSC CCIR / RS170	PAL / NTSC CCIR / RS170	PAL / NTSC CCIR / RS170
Signal	Analog	Analog	Analog	Analog
Gray scale	X	X	X	X
Color	X	X	X	X
Area scan	X	X	X	X
Nr. of real-time cameras per board	1	1	1	4
Max. cameras/board	3	4	16	16
Quick switching	-	X	X	X
Max resolution	768 x 576	768 x 576	768 x 576	768 x 576
Video output	-	-	-	4
Max I/O lines	4	13	20	13
Watchdog	-	-	X	X

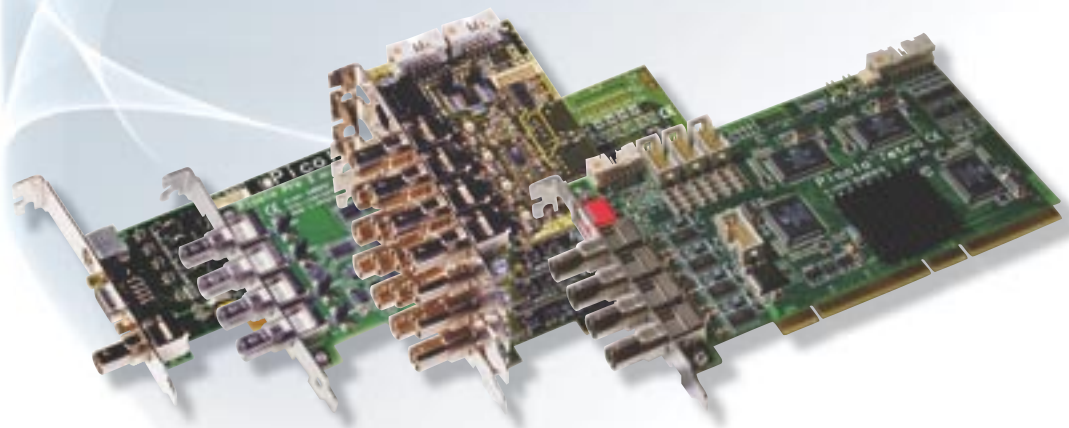

PICOLO™ series features

Video image formats

The PicoLo capture boards acquire **color or monochrome video images** from **composite interlaced video signals**. The NTSC, PAL color standards are supported. The monochrome video acquisition complies with the so-called CCIR (625 lines) and EIA (525 lines) standards.

Acquisition of **full frame (two fields)** or single field images is selectable.

Acquisition

Before PCI transfer to the PC, the acquired images can be **scaled** to any format smaller than the original one, down to 1/12. The downscaling process involves a sophisticated hardware device, performing an accurate interpolation in both the horizontal and vertical directions. The image buffer for a downscaled image is smaller in size, and its transfer needs **less PCI bandwidth**. Moreover, any part of the incoming image can be retained for further PCI transfer, allowing to **define a region of interest**.

All desirable **adjustments** can be applied to the images during acquisition, such as **video contrast, brightness, color saturation and hue** (NTSC only).



Synchronization

A fully digital technique is used to **synchronize the digitizer operation** on the incoming video signal. This ensures a **stable and robust** operation despite the varying video conditions.

Poor video signals issued by a low-end VCR are robustly supported. When using high-quality video surveillance cameras, the **acquisition performance** is exemplary, as demonstrated by a jitter figure in the **nanosecond** range.

Image fidelity

All precautions have been taken in the PicoLo series to ensure an **excellent fidelity of the grabbed bitmap** in respect of the original video signal. In particular, environmental conditions may induce common-mode noise in the signal issued by distant cameras. PicoLo Pro 2, PicoLo Pro 3 and PicoLo Tetra have special circuitry to **remove this defect**, and this is highly appreciated in the video surveillance applications.

Bitmap image formats

Before storing the acquired image into the destination memory buffer, a **pixel format conversion** takes place **in real-time**. Numerous color or monochrome formats can be chosen.

<i>PACKED</i>	<i>PACKED</i>	<i>PLANAR</i>	<i>PLANAR</i>
RGB32	YCrCb 4:2:2	YCrCb 4:2:2	YCrCb 4:1:0
RGB24	YCrCb 4:1:1	YCrCb 4:1:1	YCbCr 4:2:0
RGB16	Y8	YCrCb 4:2:0	YCbCr 4:1:0
RGB15			

Bus mastering

All PicoLo capture boards are **PCI bus mastering** agents that directly store the acquired images into the PC physical memory without CPU involvement. As a **unique feature**, the PicoLo series automatically recovers the **scatter-gather** virtual memory mapping to present the data as a regular bitmap image in a user allocated memory buffer.

Jumpers

Each PicoLo board input benefits from a **75 ohms termination resistor** enabled by a jumper or a dip-switch (PicoLo Tetra and its Video Expansion Brackets).



PICOLO™

Suitable for single camera systems
Low-cost
Industrial and video surveillance applications

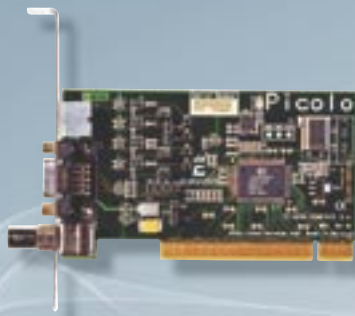

Picolo is a very **low-cost** PCI capture board optimized for **single camera applications**. It supports the acquisition and the **real-time** transfer of **full resolution color images** or sequences of images to the PC memory. Picolo captures one or two **composite** video signals and one **S-Video** signal. The square-pixel resolution (640 x 480 or 768 x 576) is achieved at full frame rate (30 or 25 fps). Picolo is the ideal capture board for **cost-sensitive applications** in the fields of machine vision, access control, x-ray inspection.

Flexible video connections

Up to three cameras can be connected. Picolo acquires images from any one of them. This table shows the allowed multiple cameras configurations.

CONNECTOR	Configuration 1	Configuration 2	Configuration 3
S-Video	1 S-Video	-	-
DB9	1 composite	2 composite	1 S-Video
BNC	1 composite	1 composite	1 composite

TTL I/O lines

Four TTL-compatible input / output lines are available on the female **DB9** connector. One line can be configured as an external acquisition trigger.

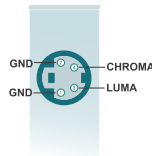

Mini DIN 4 female connector

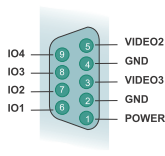

DB9 female connector

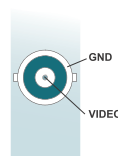

BNC

Characteristics

PCI
Size
Typical power consumption
Certification

32 bits, 33 MHz, 5 V
 121 mm x 70 mm / 4.76 in x 2.76 in
 1 W (200 mA @ 5 V)
 FCC class B and CE

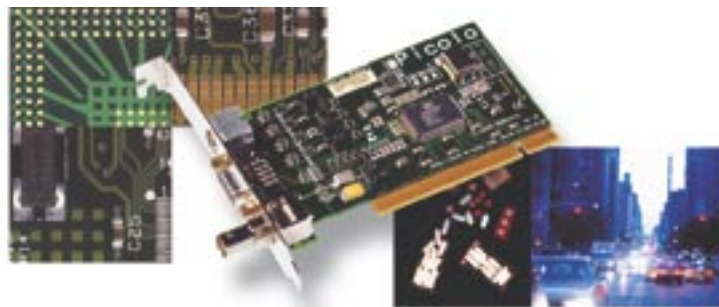

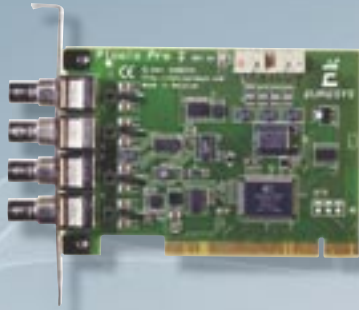

PICOLO Pro 2™

- Suitable for 4 cameras systems*
- Quick switching for superior frame rate*
- Highest image quality*
- Optimized for video surveillance*

Picolo Pro 2 is the **leading** PCI capture board specifically designed for **video surveillance** applications with **multiple cameras**. Picolo Pro 2 supports the acquisition of **full resolution color images** including the square-pixel resolution (640 x 480 or 768 x 576). **Up to 4 composite video signals** are captured directly through **standard BNC inputs**. The **quick switching** capability offers an optimized frame rate for all acquisition conditions. **TTL I/O lines** are provided for easing system integration.

Quick switching

The **multiple video inputs** of the Picolo Pro 2 are sequentially acquired using **a proprietary switching method**. The resulting switching latency for unsynchronized cameras is never more than **33 ms in NTSC** and **40 ms in PAL**. This leads to the typical following performances.

NTSC configuration	1 camera	2 cameras	3 cameras	4 cameras
Fields / Frames per second (per camera)	60 / 30	12 / 9	8 / 6	6 / 4
Fields / Frames per second (all cameras)	60 / 30	24 / 17	24 / 17	24 / 17

PAL configuration	1 camera	2 cameras	3 cameras	4 cameras
Fields / Frames per second (per camera)	50 / 25	10 / 7	7 / 5	5 / 3
Fields / Frames per second (all cameras)	50 / 25	20 / 14	20 / 14	20 / 14

Connections

Picolo Pro 2 is fitted with **four standard BNC connectors** for ruggedized camera connection. An internal **16-pin header connector** provides **13 general purpose input / output TTL lines**. They may be used for triggering image capture and interfacing to alarm system.

Characteristics

- PCI** 32 bits, 33 MHz, 5 V
- Size** 121 mm x 85 mm / 4.76 in x 3.34 in
- Typical power consumption** 1.7 W (240 mA @ 5 V, 10 mA @ +12 V, 30 mA @ -12 V)
- Certification** FCC class B and CE



PICOLO Pro 3™

Expandable architecture up to 16 cameras

Internal or external modules:

Video modules for 4 cameras or for 12 cameras in one slot

MIO isolated I/O modules

Quick switching for superior frame rate

Highest image quality

Optimized for demanding video surveillance applications

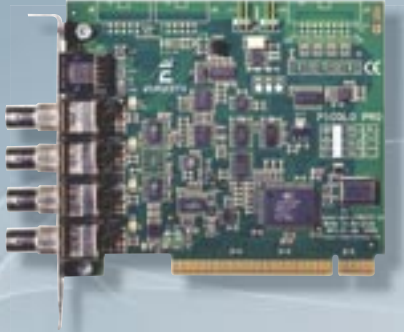

Picolo Pro 3 is a **full-featured expandable** PCI capture board designed for **multiple-camera systems** addressing **video surveillance** and **security applications**.

Picolo Pro 3 supports the acquisition of **full resolution color images** including the square-pixel resolution (640 x 480 or 768 x 576). **Up to 16 composite video signals** are captured directly through standard BNC inputs. The **quick switching** capability offers an optimized frame rate for all acquisition conditions.

A **Picolo Pro 3** solution includes one PCI board, **up to four video modules** and **up to five I/O modules**. These modules can be mounted inside or outside the PC. An **RS-485 serial line** is offered for system integration such as pan-tilt-zoom control. The **watchdog function** increases the system security.

Quick switching

The **multiple video inputs** of the Picolo Pro 3 are sequentially acquired using a **proprietary switching method**. The resulting switching latency for unsynchronized cameras is never more than **33 ms in NTSC** and **40 ms in PAL**. This leads to the typical following performances.

NTSC configuration	1 camera	4 cameras	8 cameras	12 cameras	16 cameras
Fields / Frames per second (per camera)	60 / 30	6 / 4	3 / 2	2 / 1.5	1.5 / 1
Fields / Frames per second (all cameras)	60 / 30	24 / 17	24 / 17	24 / 17	24 / 17

PAL configuration	1 camera	4 cameras	8 cameras	12 cameras	16 cameras
Fields / Frames per second (per camera)	50 / 25	5 / 3	2.5 / 2	1.5 / 1	1.2 / 0.9
Fields / Frames per second (all cameras)	50 / 25	20 / 14	20 / 14	20 / 14	20 / 14

Watchdog

A **hardware watchdog** is available on the Picolo Pro 3. Its purpose is to **monitor the software application** and to **restart the PC** after an anomalous inactivity time-out. This ensures a **reliable operation** of unattended systems.

Up to 16 BNC connectors

In an internal configuration, the Picolo Pro 3I PCI board offers **four video inputs**. Each additional internal Module Pro 3I adds four inputs. One unique additional internal Module 12 Pro 3 adds twelve inputs using one blind slot. A full 16-input external configuration consists of a Picolo Pro 3E PCI board and four external Modules Pro 3E.



Up to 20 digital TTL I/O lines and RS-485 serial line

According to the modular configuration, one to four **RJ-45 connectors** are available. Each of them offers five digital TTL I/O lines configurable as input or output. One **RS-485 half-duplex serial communication** line is bussed over all RJ-45 connectors.

Characteristics

PCI

Size

Typical power consumption

Certification

32 bits, 33 MHz, 5 V

125 mm x 107 mm / 4.92 in x 4.21 in

1.9 W (250 mA @ 5 V, 15 mA @ +12 V, 40 mA @ -12 V)

FCC class B and CE



PICOLO Pro 3™ expandable architecture

Two modular configurations are available. The **internal configuration** uses one PicoLO Pro 3I PCI board and internal video Modules Pro 3I. A more compact configuration includes one PicoLO Pro 3I capture board and one Module 12 Pro 3. The PicoLO Pro 3E PCI board associated with external video Modules Pro 3E makes up the **external configuration**.

Any application can be served with internal or external configuration with the **same performance**. Furthermore, this is **transparent to the MultiCam driver**.

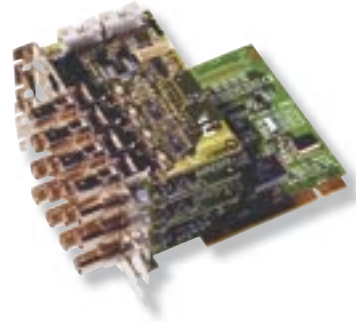

PICOLO Pro 3I™, internal configuration



Up to three Modules Pro 3I: the internal Modules Pro 3I mounted inside the PC are connected to the PicoLO Pro 3I capture board. PicoLO Pro 3I and Modules Pro 3I are **fitted each with four BNC** for video inputs and one RJ-45 connector for I/O connectivity. **Up to three Modules Pro 3I** are supported as shown in the following table.

An interconnection flat cable is provided with each Module Pro 3I.

<i>Additional internal modules connected to one PicoLO Pro 3I PCI board</i>					
	0	1	Module Pro 3I		Module 12 Pro 3
			2	3	1
Video Inputs	4	8	12	16	16
TTL I/O Lines	5	10	15	20	5



One Module 12 Pro 3: to easily add 12 video inputs using only **one** slot, connect the Module 12 Pro 3 to the PicoLO Pro 3I capture board. Therefore, the maximum number of 16 video inputs is achieved with one Module 12 Pro 3.

A spider cable is the recommended way to connect the 12 BNC video inputs to the DB25 connector. The interconnection flat cable is delivered with each Module 12 Pro 3.

PICOLO Pro 3E™, external configuration



The **external video modules** located **outside the PC** are connected to the PicoLO Pro 3E PCI board. The Modules Pro 3E are **fitted each with four BNC** for video inputs and one RJ-45 connector for I/O connectivity. PicoLO Pro 3E accepts **up to 4 external modules** leading to the following combinations.

<i>Additional Modules Pro 3E connected to one PicoLO Pro 3E PCI board</i>					
	0	1	2	3	4
Video Inputs					
PCI board	4	3	2	1	0
External modules	0	4	8	12	16
Total Video Inputs	4	7	10	13	16
TTL I/O Lines	0	5	10	15	20

Each external module acts as a four-input video switch delivering the selected video to a fifth BNC connector. The resulting video signal feeds one of the capture board video inputs through a standard coaxial cable. The RJ-45 connector located on the PicoLO Pro 3E powers and controls the external modules thanks to standard UTP cat. 5 cable.

MIO™ compatible

Each MIO module adds four optically isolated inputs and four relay outputs. A maximum of twenty isolated inputs and twenty isolated outputs is achieved with five MIO modules. For more details about MIO, see on page 10.

Characteristics

Size

63 mm x 107 mm / 2.48 in x 4.21 in

Typical power consumption

Module Pro 3I: 0.3 W (20 mA @ +12 V, 5 mA @ -12 V)
Module Pro 3E: 0.48 W (20 mA @ +12 V, 20 mA @ -12 V)
Module 12 Pro 3: 0.2 W (10 mA @ +12 V, 5 mA @ -12 V)

Module certification

Module Pro 3I: FCC class B and CE
Module 12 Pro 3: FCC class B and CE



PICOLO Tetra™



**Four color-video digitizers for video streaming and camera switching
240 fps**

64-bit, 66 MHz PCI bus

Expandable architecture:

3 Video Expansion Brackets for up to 16 camera inputs

1 Video Expansion Bracket 12 for 16 camera inputs

1 Video Expansion Bracket for 4 buffered video outputs

MIO, I/O module compatible

Picolo Tetra is a new **cost-effective** PCI capture board dedicated to high-demanding multiple cameras video surveillance applications. Picolo Tetra has a superior ability to manage streaming and switching. Thanks to its **four color video digitizers**, Picolo Tetra acquires **four real-time image sequences in parallel**. With the three video expansion brackets, this Picolo also manages efficiently **quick switching from up to sixteen cameras**.

TTL I/O lines are provided for system integration. In addition, Picolo Tetra is compatible with the **MIO module**, enabling to implement isolated inputs and outputs.

Streaming with four simultaneous video digitizers

Picolo Tetra is able to **simultaneously digitize four video signals** and to send the resulting digital data in real time into the PC memory through the PCI bus. The video streams issued from four cameras are displayed and/or recorded in parallel.

Quick switching

Adding **three Video Expansion Brackets**, Picolo Tetra provides the **four digitizers** with sixteen inputs. This maximum configuration leads to a **16-camera system**. The four digitizers of the Picolo Tetra board **are switched** between these inputs at a **very high frame rate**.

NTSC configuration	4 camera	8 cameras	12 cameras	16 cameras
Fields / Frames per second (per camera)	60 / 30	8.6 / 6.7	6 / 4.6	4.6 / 3.5
Fields / Frames per second (all cameras)	240 / 120	69 / 54	72 / 55	74 / 56
PAL configuration	4 camera	8 cameras	12 cameras	16 cameras
Fields / Frames per second (per camera)	50 / 25	7.1 / 5.6	5 / 3.8	3.8 / 2.9
Fields / Frames per second (all cameras)	200 / 100	57 / 45	60 / 46	61 / 47

64-bit, 66 MHz PCI bus

The Picolo Tetra bus capability is 64 bits at 66 MHz making this capture board compatible with the **most recent PC architectures**. This wide PCI bus supports a peak data transfer rate of **528 Mbytes/s**. Picolo Tetra is compatible with conventional PCI architecture, including **32 bits and 33 MHz**. Signaling voltage compliance is **3.3 V and 5 V** for maximum versatility.

Maximizing performance

With a top performance 64-bit 66 MHz PCI bus, Picolo Tetra is able to **simultaneously acquire full size video images in real time**. System consideration may lead to functional trade-off. In order to reach the targeted performance, the user will consider downsizing images (SIF or CIF), operating in parallel of less than four digitizers or tailoring the bitmap image format. In particular, YCrCb 4:2:2 and RGB16 formats are highly recommended.

PICOLO Tetra-RC

Picolo Tetra-RC provides a solution to customize all the 16 connections of the video inputs. The Picolo Tetra-RC performances are identical to Picolo Tetra. The suffix -RC stands for "**Remote Connection**". Picolo Tetra-RC features a blank bracket and allows to connect the 16 video inputs to a customer patchpanel.



On-board TTL I/O lines

TTL I/O lines are provided for easing system integration. An internal **16-pin header connector** provides **13 general purpose input / output TTL lines** usable for triggering image capture and interfacing to alarm system. This connector is pin to pin compatible with the Pico Pro 2 solution.

Video image formats

Picolo Tetra supports the acquisition of **full resolution images** or **any smaller-size format**, such as **SIF**. Acquisition of **full frame** (two fields) or single field images is selectable. Individual fields or frames as well as video sequences are captured directly to the PC memory. Picolo Tetra ensures an **excellent fidelity** of the grabbed bitmap in respect of the original video signal.

Watchdog

A **hardware watchdog** is available on Picolo Tetra. Its purpose is to **monitor the software application** and to **restart the PC** after an anomalous inactivity time-out. This ensures a **reliable operation** of unattended systems. This watchdog implementation is identical to the Picolo Pro 3 solution.

Expandable architecture

Video Expansion Bracket as input

Picolo Tetra is designed to receive up to three video input modules fitted each with four BNC connectors leading to a maximum configuration of sixteen connected cameras.

Video Expansion Bracket 12 as input

As an alternative, Picolo Tetra can receive **one** Video Expansion Bracket 12. It offers twelve video inputs through one DB25 connector. The maximum configuration of sixteen connected cameras is achieved with one Video Expansion Bracket 12.

The spider cable is the recommended way to connect the 12 BNC video inputs to the DB25 connector. It is provided with each Video Expansion Bracket 12 (picture on page 6).

Video Expansion Bracket as output

Four buffered video outputs are offered on an additional four-BNC module as an alternative to loop-through connecting the video sources.

These video signals represent the image applied to each internal video color digitizer.

MIO™ compatible

Each MIO module adds four optically isolated inputs and four relay outputs. A maximum of twenty isolated inputs and twenty isolated outputs is achieved with five MIO modules. For more details about MIO, see on page 10.

Dip-switch

Picolo Tetra and the Video Extension Brackets are equipped with a dip-switch to conveniently enable the 75 ohms termination resistors from outside the PC.



Characteristics

PCI

Size

Typical power consumption

Certification

64 bits, 66 MHz, 3.3 V and 5 V compliant

168 mm x 107 mm / 6.61 in x 4.21 in

8 W (1,2 A @ 5 V, 120 mA @ + 12 V, 5 mA @ - 12 V)

FCC class B and CE



MIO™

Input/Output expansion module for PICOLO Pro 3 and PICOLO Tetra

- 4 input and 4 output isolated lines**
- Alarm or Watchdog signaling features**
- Removable screw-terminal block**
- Monitoring LEDs**



MIO is a new element of the **Piccolo Pro 3 and Piccolo Tetra** modular architecture serving both the internal and external configurations. MIO brings flexible isolated logic inputs and outputs.

4 input and 4 output isolated lines

MIO offers **four opto-isolated input** and **four reed relay output lines**. They are natively supported by the MultiCam driver. Each input line is interrupt-capable, with independent edge sensitivity control. The status of the lines is monitored by eight dedicated **LEDs**.

Alarm or Watchdog signaling features

The **fourth** relay output can be configured as an **alarm, a watchdog or a standard output**. In alarm mode, as long as the application is not started, the relay remains open. Once operating correctly, the application closes the relay. In watchdog mode, as long as the application is not started, the relay remains open. Once operating correctly, the application resets regularly the watchdog timer. If a watchdog time out occurs, the relay is closed.

Removable screw-terminal block

Each line is available as a pair of electrical wires on the removable sixteen terminal block.

Characteristics

- Size**
- Typical power consumption**
- Certification**

58 mm x 107 mm / 2.28 in x 4.21 in
 1.8 W (150 mA @ +12 V)
 FCC class B and CE

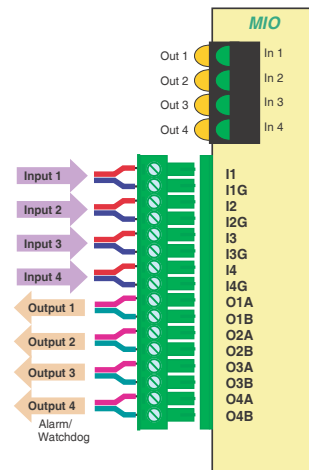

MIO Connector



PICOLO™ series software support

MultiCam™

The **MultiCam driver** enables the consistent control of several PicoLo capture boards, using an arbitrary **number of cameras**, from **one or several software applications**.

MultiCam allows defining **channels** linking cameras to buffers in the PC memory. The MultiCam channel **identifies all parameters** ruling the acquisition process from a camera. The camera features, such as its video standard, are reported through **simple parameters**. Other parameters control the acquisition conditions, such as image contrast, downscaling or acquisition rate.

The channels can be activated simultaneously. The MultiCam driver automatically manages the switching among cameras and capture boards to **optimize the acquisition speed** and the **display refresh rate**. The channel concept considerably **eases the management of video surveillance applications** using multiple cameras. Image processing applications immediately benefit from the **multitrading environment** offered by MultiCam.

MultiCam complies with most development environments. The native API is **standard C. ActiveX controls** enable the use of **Visual Basic**.



MultiCam™ for Windows and Linux



The MultiCam driver runs under Windows 98SE, Me, NT, 2000 and XP and now Linux allowing EureSYS customers to combine the ease-of use of the MultiCam driver and the eVision software tools with the cost-effectiveness of Linux. MultiCam is available under Linux RedHat 7.3 and RedHat 8.0.

EasyMultiCam™

Offered as a part of the **eVision** tools suite, **EasyMultiCam** is a **set of powerful C++ classes** embedding the whole MultiCam functionality. The **object oriented** eVision functions define image containers suitable for **image handling, display, processing and analysis**. The image objects inherit acquisition methods from EasyMultiCam. Implementing the image capture code into a video surveillance application is now straightforward.

EasyDisplay™

EureSYS offers the **EasyDisplay library**, which optimizes the transfer of captured image into the display adapter memory. This drastically **improves the display performance**. EasyDisplay manages non-destructive flicker-free overlay issued by the application.

Ordering Information

PRODUCT	NAME PRODUCT DESCRIPTION	PART NUMBER
PCI capture boards		
EureCard PICOLO	Standard video capture board	1155
EureCard PICOLO Pro 2	Pro 2 CCTV capture board with four inputs	1157
EureCard PICOLO Pro 3I	Pro 3I CCTV capture board with internal expandability	1158-I
EureCard PICOLO Pro 3E*	Pro 3E CCTV capture board with external expandability	1158-E
EureCard PICOLO Tetra	Tetra CCTV capture board with four digitizers	1303
EureCard PICOLO Tetra-RC*	Tetra CCTV capture board with four digitizers full customer connection	1303-RC
Video modules		
Module Pro 3I (cable included)	Picolo Pro 3 Internal video module with four inputs	1201-I
Module 12 Pro 3* (cables included)	Picolo Pro 3 Internal video module with twelve inputs	1205
Module Pro 3E*	Picolo Pro 3 External video module with four inputs	1201-E
Video Expansion Bracket (cable included)	Four-way Picolo Tetra Video Expansion Bracket	1203
Video Expansion Bracket 12* (cable included)	Twelve-way Picolo Tetra Video Expansion Bracket	1204
I/O modules		
MIO Module (cable included)	Isolated input / output module	1202

*products upon customer order

America, Euresys Inc.
500 Park Boulevard, suite 525, Itasca, Illinois 60143
Toll free: 1-866-EURESYS - Phone: 630-250-2300 - Fax: 630-250-2301

Asia, Euresys Pte. Ltd.
627A Aljunied Road, #08-09 BizTech Centre, Singapore 389842
Phone: +65 6748 0085 - Fax: +65 6841 2137

Japan, Euresys s.a. Japan Representative Office
AIOS Hiroo Building 8F, Hiroo 1-11-2, Shibuya-ku, Tokyo 150-0012
Phone: +81 3 5447-1256 - Fax: +81 3 5447-0529

Europe, Euresys s.a., Corporate Headquarters
14, Avenue du Pré-Ailly, B-4031 Angleur, Belgium
Phone: +32 4 367 72 88 - Fax: +32 4 367 74 66



www.euresys.com

info@euresys.com

Your distributor