

**GigE Dual Line Scan Camera**

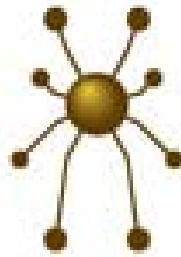

**spyder GigE**

**Spyder 3 Camera User's Manual**

**SG-10-01k80**

**SG-10-02k80**

**SG-10-01k40**

**SG-10-02k40**



30-May-07  
03-032-10158-06  
138Hwww.dalsa.com

© 2007 DALSA. All information provided in this manual is believed to be accurate and reliable. No responsibility is assumed by DALSA for its use. DALSA reserves the right to make changes to this information without notice. Reproduction of this manual in whole or in part, by any means, is prohibited without prior permission having been obtained from DALSA.

## About DALSA

DALSA is an international high performance semiconductor and electronics company that designs, develops, manufactures, and markets digital imaging products and solutions, in addition to providing semiconductor products and services. DALSA's core competencies are in specialized integrated circuit and electronics technology, software, and highly engineered semiconductor wafer processing. Products and services include image sensor components; electronic digital cameras; vision processors; image processing software; and semiconductor wafer foundry services for use in MEMS, high-voltage semiconductors, image sensors and mixed-signal CMOS chips. DALSA is listed on the Toronto Stock Exchange under the symbol "DSA". The Company has its corporate offices in Waterloo, ON and over 1000 employees worldwide.

For further information not included in this manual, or for information on DALSA's extensive line of image sensing products, please call:

## DALSA Sales Offices

| Waterloo   | Europe  | Asia Pacific  |
|--|---|---|
| 605 McMurray Rd<br>Waterloo, ON N2V 2E9<br>Canada<br>Tel: 519 886 6000<br>Fax: 519 886 8023<br>www.dalsa.com<br>sales.americas@dalsa.com | Breslauer Str. 34<br>D-82194 Gröbenzell (Munich)<br>Germany<br>Tel: +49 - 8142 - 46770<br>Fax: +49 - 8142 - 467746<br>www.dalsa.com<br>sales.europe@dalsa.com | Ikebukuro East 13F<br>3-4-3 Higashi-Ikebukuro<br>Toshima-ku, Tokyo 170-0013<br>Japan<br>Tel: 81 3 5960 6353<br>Fax: 81 3 5960 6354 (fax)<br>www.dalsa.com<br>sales.asia@dalsa.com |

# Contents

|   |           |
|---|-----------|
| <b>Introduction to the Spyder 3 GigE Camera</b>           | <b>5</b>  |
| 1.1 Camera Highlights                                     | 6         |
| 1.2 Camera Performance Specifications                     | 7         |
| 1.3 Image Sensor  | 10        |
| 1.4 Responsivity  | 13        |
| 1.5 Derating Curves                                       | 13        |
| <b>Setting Up the Camera</b>                              | <b>17</b> |
| 2.1 Installation Overview                                 | 18        |
| 2.2 Equipment Recommendations                             | 20        |
| 2.3 Drivers: Overview                                     | 22        |
| 2.4 Camera Connectors                                     | 23        |
| 2.4.1 Ethernet Connector                                  | 24        |
| 2.4.2 Power Connector                                     | 25        |
| 2.4.3 GPIO Connector                                      | 25        |
| 2.5 Camera LED  | 27        |
| 2.6 Camera Timing   | 28        |
| <b>Controlling the Camera</b>                             | <b>31</b> |
| 3.1 QuickCam Interface                                    | 32        |
| 3.2 Using ASCII Commands                                  | 33        |
| 3.3 First Power Up Camera Settings                        | 35        |
| <b>Optical, Mechanical, and Electrical Considerations</b> | <b>37</b> |
| 4.1 Mechanical Interface                                  | 38        |
| 4.2 Optical Interface                                     | 39        |
| 4.3 Electrical Interface                                  | 40        |
| <b>CCD Handling Instructions</b>                          | <b>43</b> |
| 5.1 Electrostatic Discharge and the CCD Sensor            | 44        |
| 5.2 Protecting Against Dust, Oil and Scratches            | 44        |
| 5.3 Cleaning the Sensor Window                            | 45        |
| <b>Troubleshooting</b>                                    | <b>47</b> |
| <b>6.1 Troubleshooting</b>                                | <b>48</b> |
| 6.2 Specific Solutions                                    | 50        |

|   |            |
|---|------------|
| 6.3 Product Support.....  | 52         |
| <b>Spyder 3 GigE ASCII Commands</b> .....                           | <b>53</b>  |
| A1 Sensor Output Format.....  | 56         |
| A1.1 Sensitivity Mode.....  | 56         |
| A1.2 CCD Shift Direction .....                                      | 56         |
| A1.3 Setting the Bit Depth and Data Mode .....                      | 57         |
| A1.4 Exposure Mode, Readout Mode, Line Rate and Exposure Time ..... | 57         |
| A1.5 Configuring the GPIO Connector .....                           | 63         |
| A2 Data Processing.....   | 65         |
| A2.1 Setting a Region of Interest (ROI).....                        | 65         |
| A2.2 Analog and Digital Signal Processing Chain.....                | 66         |
| A2.3 End-of-line Sequence .....                                     | 80         |
| A3 Saving and Restoring Settings .....                              | 82         |
| A3.1 Saving and Restoring PRNU and FPN Coefficients.....            | 83         |
| A3.2 Rebooting the Camera.....                                      | 84         |
| A4 Diagnostics .....  | 84         |
| A4.1 Generating a Test Pattern .....                                | 84         |
| A4.1.1 Ethernet Test Pattern.....                                   | 85         |
| A4.2 Returning Video Information .....                              | 86         |
| A4.3 Temperature Measurement.....                                   | 87         |
| A4.4 Voltage Measurement.....                                       | 87         |
| A4.5 Camera Frequency Measurement.....                              | 88         |
| A4.6 Returning the LED Status.....                                  | 88         |
| A4.7 Returning Camera Settings .....                                | 89         |
| A5 Error Handling .....   | 103        |
| A6 Clearing Dark Current.....                                       | 105        |
| Immediate read out mode (default, srm 2).....                       | 106        |
| Gate dark current clear mode (always on, srm 1) .....               | 106        |
| Auto Mode (srm 0).....  | 107        |
| <b>EMC Declaration of Conformity</b> .....                          | <b>113</b> |
| <b>Revision History</b> .....                                       | <b>115</b> |
| <b>Index</b> .....  | <b>117</b> |

# 1

---

## Introduction to the Spyder 3 GigE Camera

### *Chapter Contents*

|  |           |
|--|-----------|
| <b>1.1 Camera Highlights</b>                 | <b>6</b>  |
| Features .....                               | 6         |
| Programmability .....                        | 6         |
| Description .....                            | 6         |
| Applications .....                           | 6         |
| Models .....                                 | 7         |
| <b>1.2 Camera Performance Specifications</b> | <b>7</b>  |
| <b>1.3 Image Sensor</b>                      | <b>10</b> |
| Sensitivity Mode and Pixel Readout .....     | 10        |
| Sensor Shift Direction .....                 | 12        |
| <b>1.4 Responsivity</b>                      | <b>13</b> |

# 1.1 Camera Highlights

## *Features*

- Broadband responsivity up to  $408 \pm 16 \text{DN}(\text{nJ}/\text{cm}^2)$  @10dB gain
- 1024 or 2048 pixels,  $14\mu\text{m} \times 14\mu\text{m}$  pixel pitch, 100% fill factor
- High or low speed (40 or 80MHz)
- Up to 68KHz line rates
- Dynamic range up to 1400 : 1
- Data transmission up to 100m
- $\pm 50\mu\text{m}$  x, y sensor alignment

## *Programmability*

- Easy to use graphical user interface
- Serial interface (ASCII, 9600 baud, adjustable to 19200, 57600, 115200), through virtual serial port through Ethernet
- Programmable gain, offset, exposure time and line rate, trigger mode, test pattern output, and camera diagnostics
- Tall pixel, high sensitivity, or low sensitivity mode available.
- Flat-field correction – minimizes lens vignetting, non-uniform lighting, and sensor FPN and PRNU.

## *Description*

The Spyder 3 GigE camera is DALSA's first GigE camera. With a GigE interface, you no longer need a frame grabber which means significant system cost savings.

The Spyder 3 GigE is also DALSA's first dual line scan camera. When operating in high sensitivity (dual line scan) mode, the Spyder 3 GigE camera has 3x the responsivity of a DALSA's Spyder2 line scan camera.

## *Applications*

The Spyder 3 GigE camera is ideal for:

- FPD inspection
- Pick and place
- Container inspection
- Wood/tile/steel inspection

- 100% print inspection (lottery tickets, stamps, bank notes, paychecks)
- Postal sorting
- Glass bottle inspection
- Industrial metrology
- Food inspection
- Web inspection

*Models*

The Spyder 3 GigE camera is available in these models.

**Table 1: Spyder 3 GigE Camera Models Overview**

| Model Number | Description                                   |
|--------------|---|
| SG-10-01K80  | 1k resolution, 2 sensor taps, 80MHz data rate |
| SG-10-02K80  | 2k resolution, 2 sensor taps, 80MHz data rate |
| SG-10-01K40  | 1k resolution, 1 sensor tap, 40MHz data rate  |
| SG-10-02K40  | 2k resolution, 1 sensor tap, 40MHz data rate  |

## 1.2 Camera Performance Specifications

**Table 2: Spyder 3 GigE Camera Performance Specifications**

| Feature / Specification   | Units    | 1k                        | 2k                        | Notes  |
|---------------------------|----------|---------------------------|---------------------------|--|
| Imager Format             |          | dual line scan            | dual line scan            |  |
| Resolution                | pixels   | 1024                      | 2048                      |  |
| Pixel Fill Factor         | %        | 100                       | 100                       |  |
| Pixel Size                | µm       | 14x14                     | 14x14                     |  |
| Output Format (# of taps) |          | 1 or 2 depending on model | 1 or 2 depending on model |  |
| Sensitivity Mode          |          | High, low, or tall pixel  | High, low, or tall pixel  |  |
| Antiblooming              |          | 100x                      | 100x                      |  |
| Gain Range                | dB       | ±10                       | ±10                       |  |
| Optical Interface         | Units    |                           |                           | Notes  |
| Back Focal Distance       | M42x1 mm | 6.56±0.25                 |                           | Lens mount adapters are available. Contact Sales for more information. |
| Sensor Alignment          | x µm     | ±50                       |                           |  |
|                           | y µm     | ±50                       |                           |  |
|                           | z mm     | ±0.25                     |                           |  |
|                           | θz °     | ±0.2                      |                           |  |

| Feature / Specification     | Units | 1k                          | 2k        | Notes                             |
|-----------------------------|-------|-----------------------------|-----------|-----------------------------------|
| <b>Mechanical Interface</b> |       |                             |           | <b>Notes</b>                      |
| Camera Size                 | mm    | 72(h) x 60(l) x 50(w)       |           |                                   |
| Mass                        | g     | <300                        |           |                                   |
| Connectors                  |       |                             |           |                                   |
| power connector             |       | 6 pin male Hirose           |           |                                   |
| GigE connector              |       | RJ45                        |           |                                   |
| GPI/O connector             |       | High density dsub           |           |                                   |
| <b>Electrical Interface</b> |       |                             |           | <b>Notes</b>                      |
| Input Voltage               | Volts | +12 to +15                  |           |                                   |
| Power Dissipation           | W     | <8.5                        |           |                                   |
| Operating Temperature       | °C    | 0 to 50                     |           |                                   |
| Bit Width                   | Bits  | 8 or 12 bit user selectable |           |                                   |
| Output Data Configuration   |       | GigE                        |           |                                   |
| <b>Speed</b>                |       | <b>1k</b>                   | <b>2k</b> | <b>Notes</b>                      |
| Minimum Line Rate           | kHz   | 1                           | 1         |                                   |
| Maximum Line Rate           | kHz   | 80MHz model                 | 36        |                                   |
|                             |       | 40MHz model                 | 18.5      |                                   |
| Data Rate                   | MHz   | 40 or 80                    | 40 or 80  | Data rate depends on camera model |

| Operating Specifications (12 bit values, Flat Field Correction enabled) |                       |       |        |      |       |       |     |       |       |      |       |
|---|-----------------------|-------|--------|------|-------|-------|-----|-------|-------|------|-------|
| Specification   | Unit                  | -10dB |        |      | 0dB   |       |     | +10dB |       |      | Notes |
|   |                       | Min   | Typ    | Max  | Min   | Typ   | Max | Min   | Typ   | Max  |       |
| Broadband Responsivity (dual line)                                      | DN/nJ/cm <sup>2</sup> | 38.8  | 40.8   | 42.8 | 124   | 129   | 134 | 392   | 408   | 424  |       |
| Broadband Responsivity (single line)                                    | DN/nJ/cm <sup>2</sup> |       | 20.4   |      |       | 62    |     |       | 204   |      |       |
| Random Noise rms  | DN                    |       |        | 8    |       | 19.2  | 24  |       | 60    | 76.8 |       |
| Dynamic Range (Dual Line)   | ratio                 | 500:1 | 1400:1 |      | 203:1 | 324:1 |     | 59:1  | 108:1 |      |       |
| Dynamic Range (Single Line)   | ratio                 | 500:1 | 1400:1 |      | 203:1 | 324:1 |     | 59:1  | 108:1 |      |       |
| FPN Global  |                       |       |        |      |       |       |     |       |       |      |       |
| Uncorrected   | DN                    |       |        | 52.8 |       |       |     |       |       | 536  |       |
| Corrected   | DN                    |       |        | 32   |       |       | 32  |       |       | 64   |       |

| Operating Specifications (12 bit values, Flat Field Correction enabled) |                    |       |      |      |     |         |      |       |      |      |       |
|---|--------------------|-------|------|------|-----|---------|------|-------|------|------|-------|
| Specification   | Unit               | -10dB |      |      | 0dB |         |      | +10dB |      |      | Notes |
|   |                    | Min   | Typ  | Max  | Min | Typ     | Max  | Min   | Typ  | Max  |       |
| PRNU ECD  |                    |       |      |      |     |         |      |       |      |      |       |
| Uncorrected Local   | %                  |       |      | 8.5% |     |         | 8.5% |       |      | 8.5% | 1     |
| Uncorrected Global  | %                  |       |      | 10%  |     |         | 10%  |       |      | 10%  |       |
| Corrected Local   | DN p-p             |       |      | 32   |     |         | 32   |       |      | 64   |       |
| Corrected Global  | DN p-p             |       |      | 32   |     |         | 32   |       |      | 64   |       |
| PRNU ECE  |                    |       |      |      |     |         |      |       |      |      |       |
| Uncorrected Local   | %                  |       |      | 8.5% |     |         | 12%  |       |      | 37%  |       |
| Uncorrected Global  | %                  |       |      | 10%  |     |         | 12%  |       |      | 37%  |       |
| Corrected Local   | DN p-p             |       |      | 80   |     |         | 208  |       |      | 752  |       |
| Corrected Global  | DN p-p             |       |      | 80   |     |         | 208  |       |      | 752  |       |
| SEE (calculated)  |                    |       |      |      |     |         |      |       |      |      |       |
| Dual line   | nJ/cm <sup>2</sup> |       | 6.75 |      |     | 2.14    |      |       | 0.68 |      |       |
| Single line   |                    |       | 13.5 |      |     | 4.29    |      |       | 1.35 |      |       |
| NEE (calculated)  |                    |       |      |      |     |         |      |       |      |      |       |
| Dual line   |                    |       | 13.6 |      |     | 10.3    |      |       | 10.2 |      |       |
| Single line   |                    |       | 27.2 |      |     | 20.8    |      |       | 20.4 |      |       |
| Sat. Output Amplitude   | DN                 |       |      |      |     | 3968±80 |      |       |      |      |       |
| DC Offset   | DN                 |       |      | 96   |     |         | 160  |       |      | 336  |       |

**Test conditions unless otherwise noted:**

- CCD Pixel Rate: 40 MHz per sensor tap
- Line Rate: 5000 Hz
- Nominal Gain setting unless otherwise specified
- Light Source: Broadband Quartz Halogen, 3250k, with 750 nm highpass filter installed
- Ambient test temperature 25 °C
- Unless specified, all values are referenced at 12 bit
- Exposure mode disabled.
- Unless specified, dual line mode.

**Notes**

1. PRNU measured at 50% SAT.

## 1.3 Image Sensor

The camera uses DALSA's dual line scan sensor. The camera can be configured to read out in either high or low sensitivity mode, tall pixel mode, and forward or reverse shift direction.

**Figure 1: 2 Tap Sensor Block Diagram (SG-10-01K80, SG-10-02K80)**

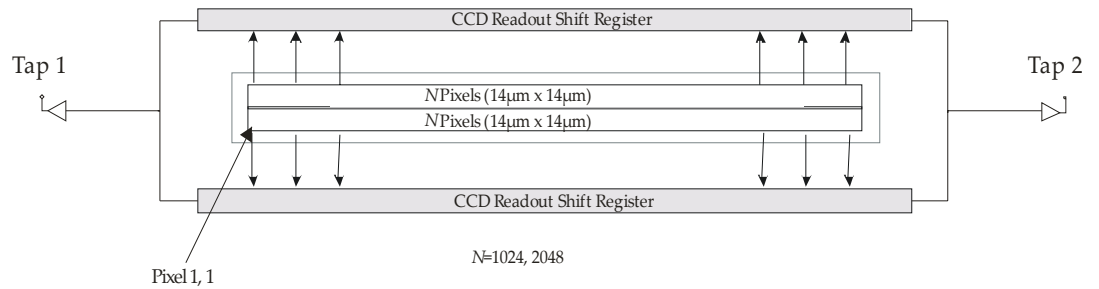

**Figure 2: 1 Tap Sensor Block Diagram (SG-10-01K40, SG-10-02K40)**

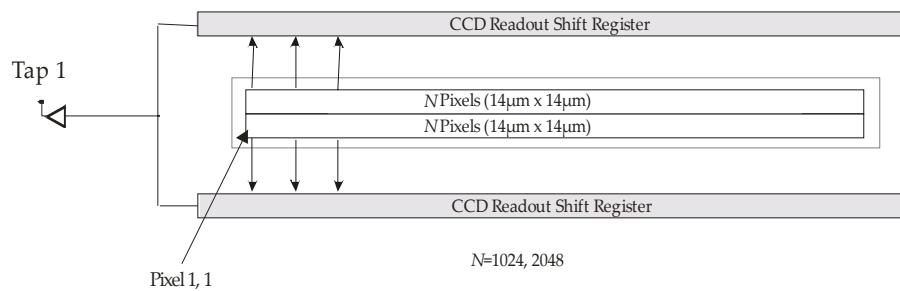

### Sensitivity Mode and Pixel Readout

The camera has the option to operate in either high sensitivity or low sensitivity mode or in tall pixel mode. When in high sensitivity mode, the camera uses both line scan sensors and its responsivity increases accordingly. When in low sensitivity mode, the camera uses the bottom sensor. When operating in tall pixel mode, the camera operates using both sensors, creating a  $28\mu\text{m} \times 14\mu\text{m}$  pixel. The sensitivity mode is software controlled through QuickCam or through the ASCII command **ssm**.

**Figure 3: High Sensitivity Mode**

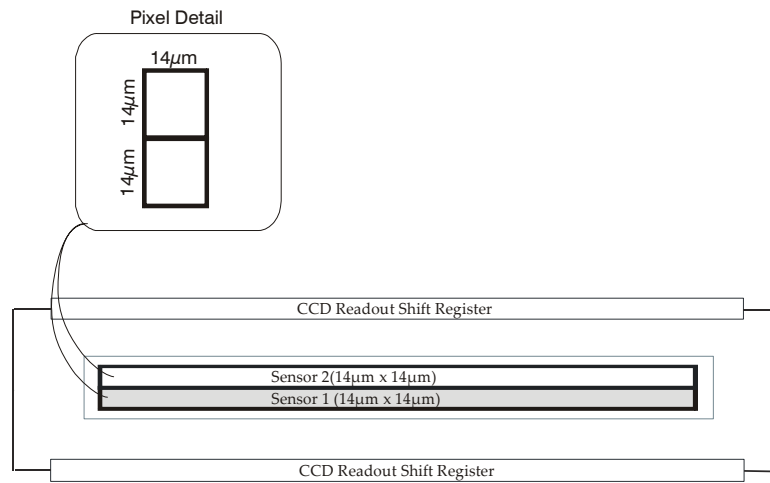

In high sensitivity mode, the camera uses a 14µm x 14µm pixel and captures the same image twice, creating a brighter image.

**Figure 4: Low Sensitivity Mode**

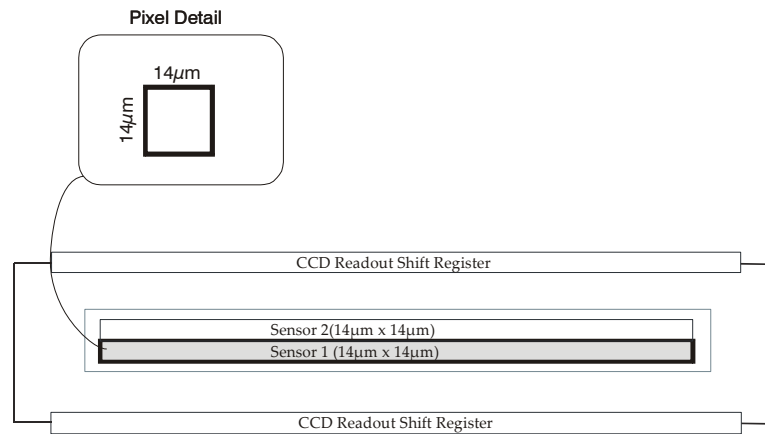

In low sensitivity mode, the camera uses a 14µm x 14µm pixel and captures the image using one sensor (Sensor 1).

**Figure 5: Tall Pixel Mode**

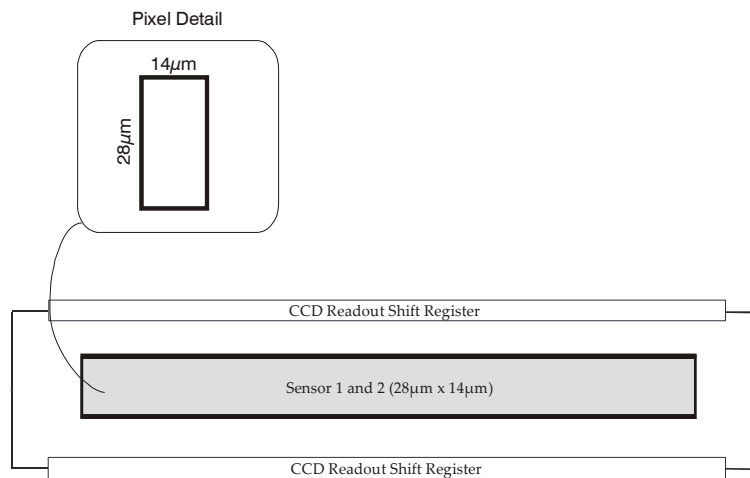

In tall pixel mode, the camera uses a 28µm x 14µm pixel and captures an image two times taller than in high or low sensitivity mode, creating a taller image.

## Sensor Shift Direction

When in high sensitivity mode, you can select either forward or reverse CCD shift direction. This accommodates object direction change on a web and allows you to mount the camera "upside down".

**Figure 6: Object Movement and Camera Direction Example using an Inverting Lens**

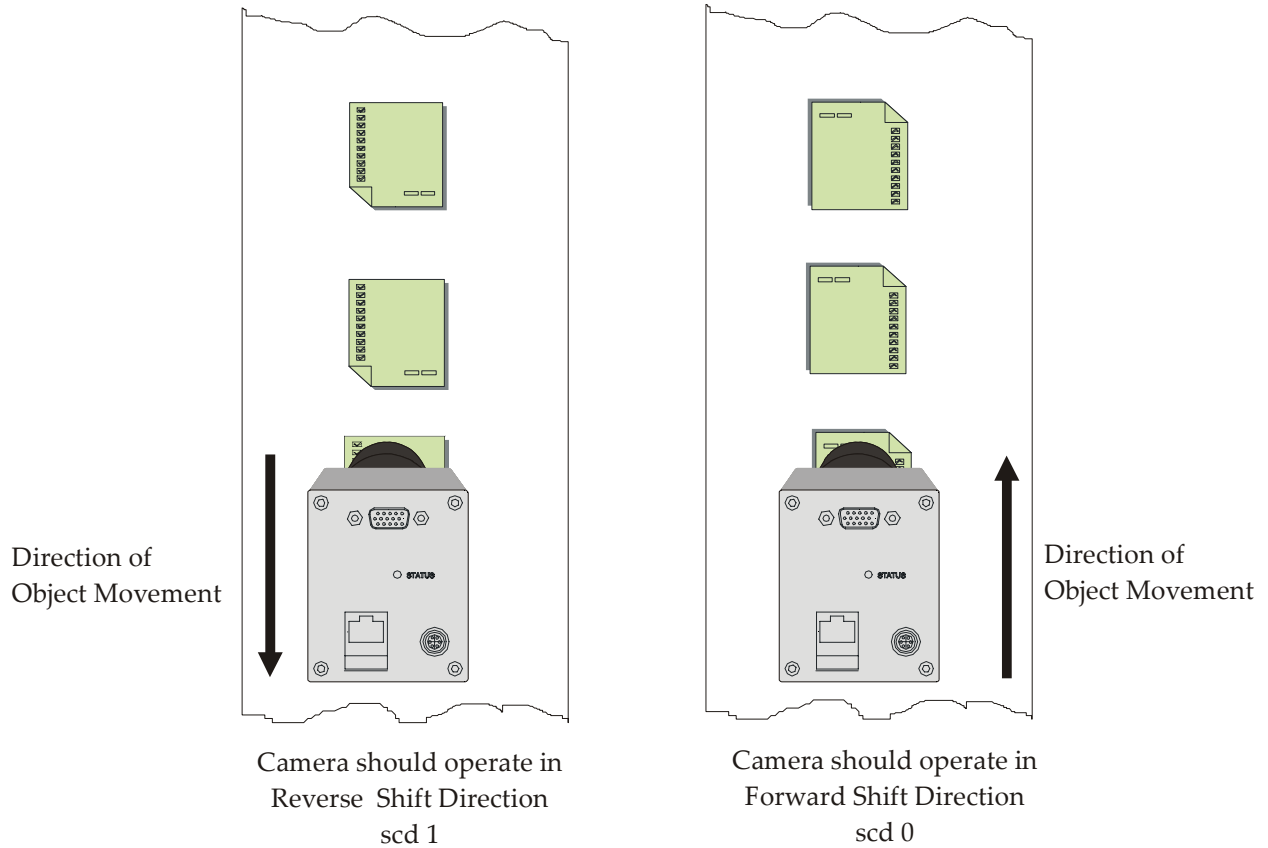

# 1.4 Responsivity

Figure 7: Spyder 3 GigE Responsivity

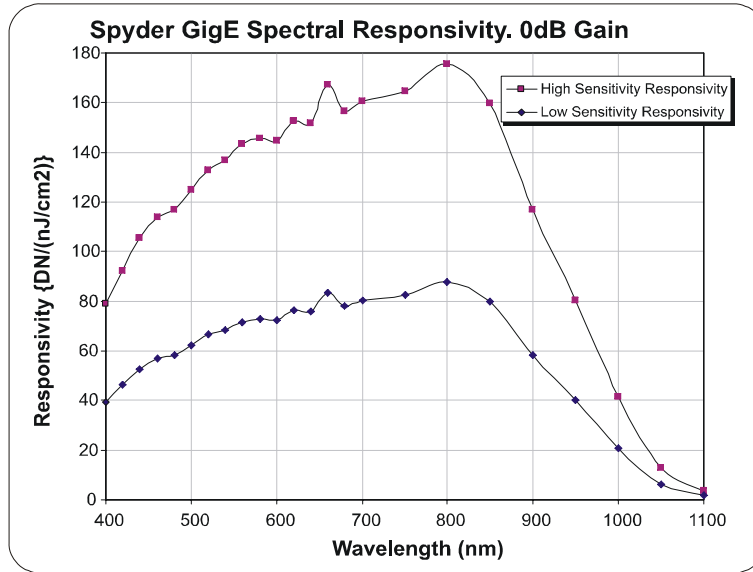

Refer to section 1.3 Image Sensor for a description of high and low sensitivity modes.

# 1.5 Derating Curves

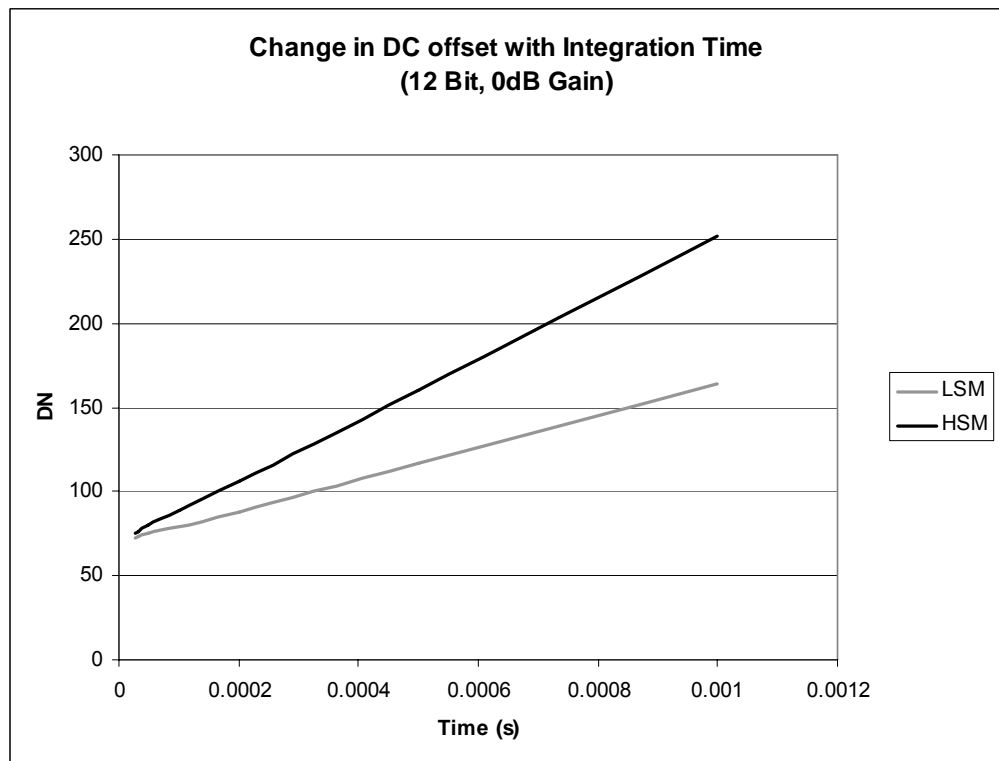

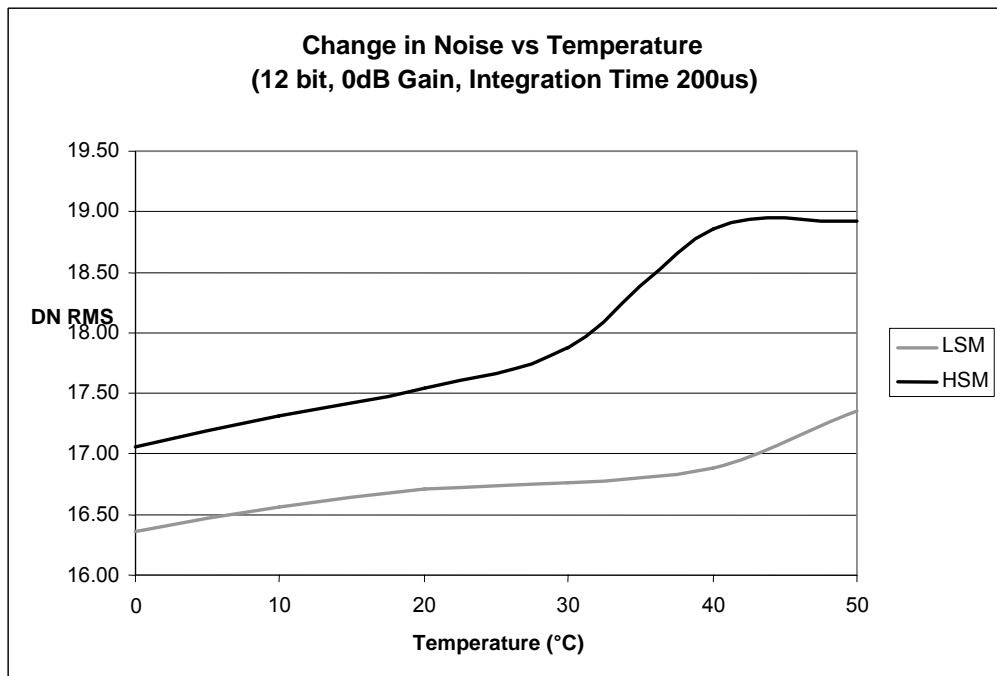
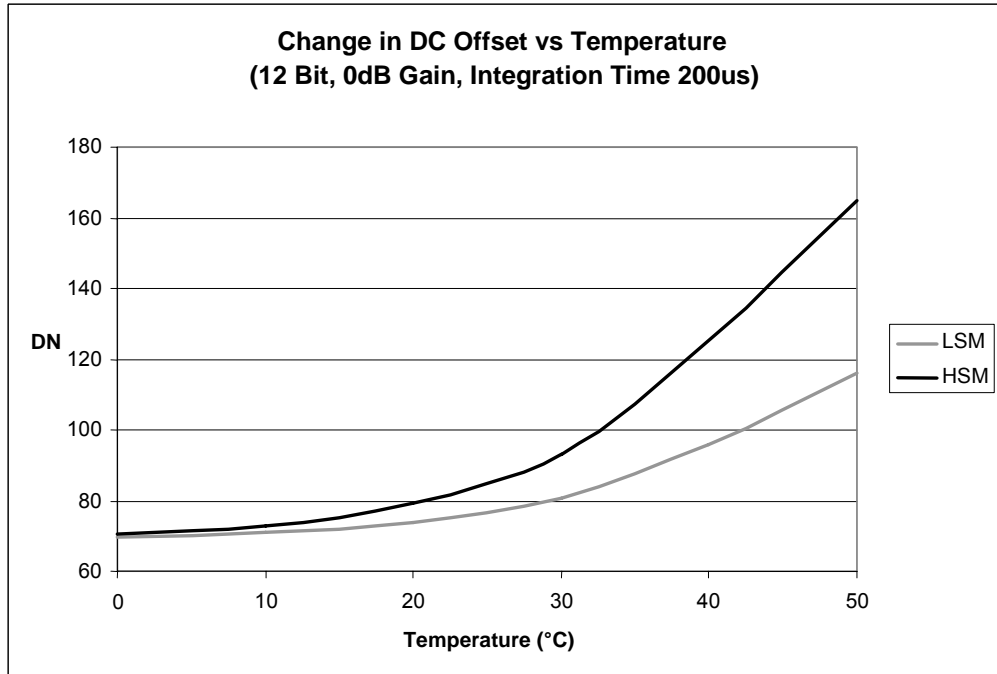

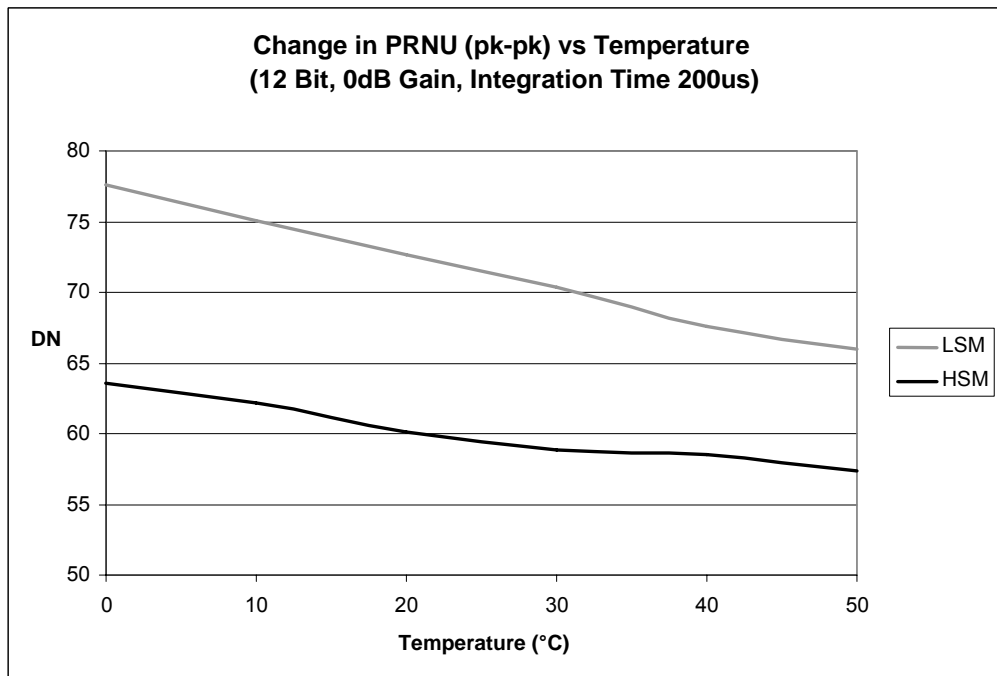
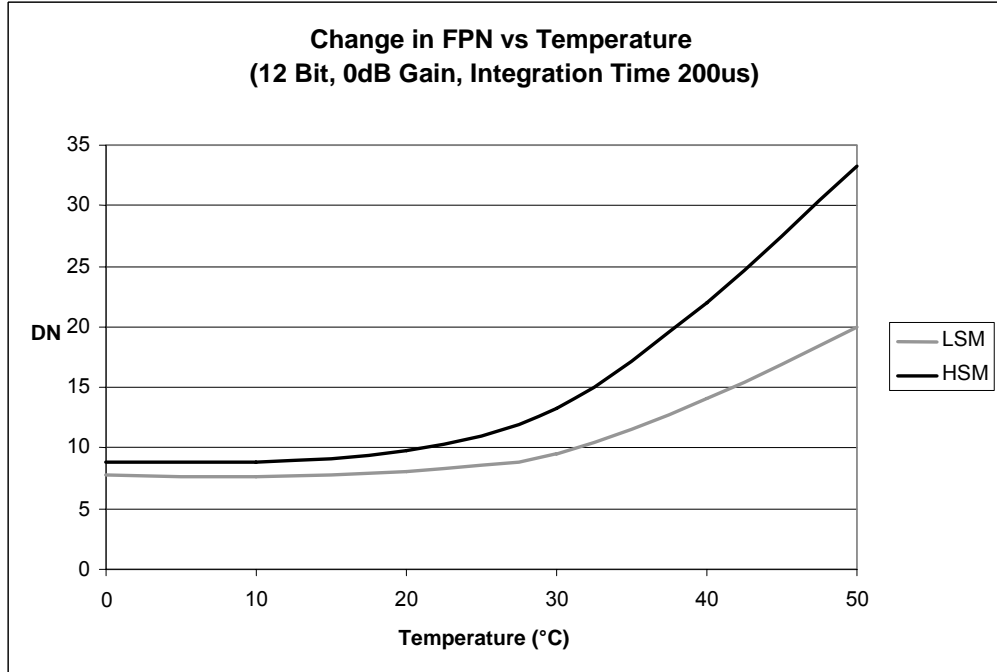



# 2

---

## Setting Up the Camera

### *Chapter Contents*

|   |           |
|---|-----------|
| <b>2.1 Hardware Installation Overview</b>           | <b>18</b> |
| <b>2.2 Equipment Recommendations</b>                | <b>20</b> |
| PC Requirements .....                               | 20        |
| Network Adapter Requirements .....                  | 20        |
| Ethernet Switch Requirements.....                   | 21        |
| Fiber-Optic Interface Requirements .....            | 21        |
| <b>2.3 Drivers: Overview</b>                        | <b>22</b> |
| High Performance Driver Mode.....                   | 22        |
| Standard Driver Mode .....                          | 22        |
| DALSA NetLink Universal IP Filter Driver Mode ..... | 23        |
| Driver Comparison.....                              | 23        |
| <b>2.4 Camera Connectors</b>                        | <b>23</b> |
| TTL Inputs and Outputs .....                        | 26        |
| LVDS Inputs and Outputs .....                       | 27        |
| Programming the GPIO Connector.....                 | 27        |
| <b>2.5 Camera LED</b>                               | <b>27</b> |
| <b>2.6 Camera Timing</b>                            | <b>30</b> |

## 2.1 Installation Overview



1

### Install Ethernet card.

Following the manufacturer's instructions, install an Ethernet card. For Gigabit performance, you must install an Intel PRO/1000 Ethernet card.

**⚠ Do not install the manufacturer's driver.** You will install the appropriate QuickCam driver in step 3.

2

### Install QuickCam GUI.

Insert the **Spyder3 GigE CD** into your CD-ROM and follow the online instructions to install the QuickCam GUI.



3

### Install QuickCam driver.

1. **Open the Driver Installation Tool.** On the Windows task bar click **Start**, point to **Programs—DALSA QuickCam—Tools—Launch Driver Installation Tool**.
2. If you are using an **Intel PRO/1000 adapter**:

- a) On the **Pro 1000 Adapters** tab, right-click on an Intel PRO/1000 network interface card adapter with no installed driver (i.e. when the Device Class is Ethernet Controller).

The following context menu appears:

|   |
|---|
| Install High Performance IP Device Driver...<br>Install Intel Network Driver... |
|---|

- b) Choose **Install High Performance IP Device Driver** to install the QuickCam High Performance IP Device Driver.

If you are **NOT** using an **Intel PRO/1000 adapter**:

- a) On the **Universal IP Filter Driver** tab, click, **Install Filter Driver...** This button installs the QuickCam Universal IP Filter Driver on ALL network adapters installed on the system that are using a network driver. This excludes PRO/1000 adapters on which the QuickCam High-Performance Driver has been installed.



4

**GPIO Connector**

If using an external sync, external direction control or any other external signals, connect the GPIO.



5

**Connect Ethernet cable.**

Connect Cat 5 or Cat 6 cable from camera to computer Ethernet jack.

6

**Connect power cable.**

Connect power cable from camera to +12 V to +15 V power supply.

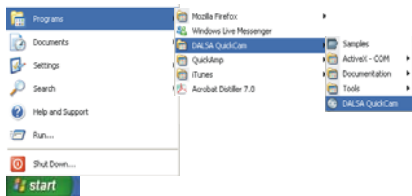

7

**Open QuickCam.**

On the Windows task bar click , **Start** point to **Programs—DALSA QuickCam—DALSA QuickCam.**

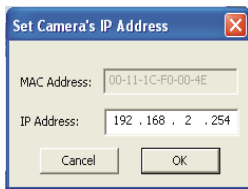

8

**Confirm or enter your IP Address.**

In the **Set Camera's IP Address** dialog box, confirm or enter the camera's IP Address. Click **OK**.



9

**Start acquiring images.**

On the QuickCam toolbar, click the **Continuous Grab** icon. The image should be visible in the Image Output window.

**Note: Refer to the following sections for details on equipment recommendations and camera connector information.**

## 2.2 Equipment Recommendations

### PC Requirements

To achieve best performance, the following minimum requirements are recommended:

- Processor: AMD Athlon XP 2000+ or Intel P4 2.0GHz
- Memory: 512MB DDR-RAM PC2700
- Motherboard: Mid-end without embedded graphic card. Avoid using onboard video cards as they may compete with other components for shared memory.
- VGA card: Nvidia GForce 2 or better (ATI not recommended). Some ATI video cards will use a high amount of the PCI bandwidth and compete with other components, such as the GigE network card. This may lower the expected data rate of applications.
- GigE network adapter (either PCI card or LOM): For high performance, you must use a Intel PRO/1000 MT adapter
- Operating system: Windows 2000 (SP4), Windows XP Professional

### Network Adapter Requirements

The Spyder 3 GigE camera works only with network adapters based on the Intel 82546, 82541, and 82540 network chips. The driver will also function with adapters based on the Intel 82544 chip, but these are not recommended due to bugs in the chip that can cause control packets to be lost if sent while data is streaming.

The PCI ID for some OEM network adapters may not be automatically recognized by the Spyder 3 GigE camera. If this occurs, contact DALSA to obtain an updated INF file.

The following four Intel network adapters are recommended and are the only adapters that are compatible with the high performance driver:

1. Intel® Pro/1000 GT Desktop Adapter (33-MHz, 32-bit PCI):  
[http://www.intel.com/network/connectivity/products/pro1000gt\\_desktop\\_adapter.htm](http://www.intel.com/network/connectivity/products/pro1000gt_desktop_adapter.htm)  
Order Code: PWLA8391GT (single packs)
2. Intel PRO/1000 MT Server Adapter (up to 133-MHz, up to 64-bit PCI-X) Family:  
[http://www.intel.com/network/connectivity/products/server\\_adapters.htm](http://www.intel.com/network/connectivity/products/server_adapters.htm)  
Order Code: PWLA8490MT (single packs)  
Order Code: PWLA8490MTBLK5 (five packs)
3. Intel® PRO/1000 MT Dual Port Server Adapter  
Order Code: PWLA8492MT (Single Packs)  
Order Code: PWLA8492MTBLK5 (Five Packs)

4. Intel® PRO/1000 GT Quad Port Server Adapter  
[http://www.intel.com/network/connectivity/products/pro1000gt\\_quadport\\_server\\_adapter.htm](http://www.intel.com/network/connectivity/products/pro1000gt_quadport_server_adapter.htm)

Order Code:PWLA849GT (Single Packs)

LAN on the motherboard (LOM) chips from Intel are also supported. Contact DALSA for information on how to use these network chips with the DALSA QuickCam High-Performance IP Device Driver.

## Ethernet Switch Requirements

When you require more than one device on the same network or a camera-to-PC separation of more than 100 metres, you can use an Ethernet switch. Since the Spyder 3 GigE camera complies with the Internet Protocol, the camera should work with all standard Ethernet switches. However, switches offer a range of functions and performance grades, so care must be taken to choose the right switch for a particular application. The following switches are expected to work with the camera:

- SMC ([www.smc.com](http://www.smc.com)) TigerSwitch 86xxT family  
Features: Layer 2 with IGMP v2.0 managed switch that supports jumbo frames and multicast
- 3COM ([www.3com.com](http://www.3com.com)) 3C1740x (3800 Family):  
Features: Layer 2 with IGMP v2.0 managed switch that supports multicast
- Dlink ([www.dlink.com](http://www.dlink.com)) DGS-10xxTx 10/100/1000 family:  
Features: Layer 2 unmanaged switch that converts multicast into a broadcast
- 3COM ([www.3com.com](http://www.3com.com)) 3C1770x (4900 Family):  
Features: Layer 2 non-blocking switch that converts multicast into a broadcast
- Dlink ([www.dlink.com](http://www.dlink.com)) DGS-3308FG & DGS-3308-TG  
Features: Layer 3 non-blocking switch that supports multicast
- Cisco ([www.cisco.com](http://www.cisco.com)) WS-C3750G-12S-S:  
Features: Layer 3 switch that supports multicast

## Fiber-Optic Interface Requirements

In cases where no intervening switch is desired and camera-to-PC separations of more than 100 meters are required, a fiber-optic media converter can be used with the Spyder 3 GigE camera.

The FlexPoint GX from Omnitron Systems ([www.omnitron-systems.com](http://www.omnitron-systems.com)) converts GigE to fiber and vice versa. It supports multimode (MM) fiber over distances of up to 220 m (720 ft.) and single-mode (SM) fiber up to 65 km (40 mi.) with SC, MT-RJ, or LC connector types.

**Note:** Although these products are known to work with the Spyder 3 GigE camera, their inclusion in this manual does not guarantee they will meet specific application requirements.

## Shielded Ethernet Cable Requirements

In order to achieve EMC compliance, the Spyder 3 camera requires the use of shielded CAT5e or CAT6 Ethernet cables.

## 2.3 Drivers: Overview

### High Performance Driver Mode

In high-performance mode, the Spyder 3 GigE works with the High-Performance IP Device Driver to transfer data between cameras and PCs with very low, predictable latency at rates of up to 1 Gb/s (100 MB/s). The video data is streamed directly into PC memory using almost no PC CPU resources. This leaves the CPU free to process applications.

To achieve this performance level, PCs must be equipped with a GigE network interface (also referred to as a network adapter) based on Intel's 82540 chip. Many motherboard manufacturers are designing this chip directly into their board in "LAN on the motherboard (LOM)" implementations. Alternately, an Intel 82540-based network adapter, also known as a network interface card, can be slotted into a PC.

**Note:** For more information and instructions on installing the drive, refer to the Spyder 3 GigE Driver Manual. To view the manual, point to **Programs** → **DALSA QuickCam** → **Documentation** → **Spyder 3 GigE Driver Manual**

**Note:** The DALSA NetLink IP Device Driver supports LOM implementations, but the PCI identification number for these may be different. Contact DALSA to obtain a driver installation file compatible with LOMs.

### Standard Driver Mode

In standard mode, the Spyder 3 GigE operates with any vendor's Ethernet network adapter. The driver shipped with the adapter transfers the data to the Windows network stack, which handles IP communications tasks.

Standard mode is recommended for applications where flexibility is more important than performance. The Windows network stack uses significant levels of CPU processing power to transfer data to memory, which can result in lost packets, severely degrading performance.

Standard mode is thus suitable for applications that require bandwidths of only 100 Mb/s or less. If this mode is used with bandwidths of 1 Gb/s, application performance will greatly degrade when CPU usage hits 100%. Additionally, at high rates like these, insufficient CPU resources may be available to process or even display images.

**Note:** For more information and instructions on installing the drive, refer to the Spyder 3 GigE Driver Manual. To view the manual, point to **Programs** → **DALSA QuickCam** → **Documentation** → **Spyder 3 GigE Driver Manual**

## DALSA NetLink Universal IP Filter Driver Mode

The Universal IP Filter Driver mode is recommended for applications where flexibility is more important than performance, but more performance is required than can be achieved using only the Windows network stack.

Similar to the drivers used in standard mode, the Universal IP Filter Driver interoperates with any vendor's Ethernet network adapter. The driver shipped with the adapter is still employed, but it communicates with the Filter Driver, instead of with the Windows network stack.

All packets related to imaging are processed with high efficiency by the Universal IP Filter Driver. Other packets are forwarded to the Windows stack. In this way, a single network adapter can support both an imaging application and normal corporate LAN functions, such as web browsing and email.

**Note:** For more information and instructions on installing the drive, refer to the Spyder 3 GigE Driver Manual. To view the manual, point to **Programs** → **DALSA QuickCam** → **Documentation** → **Spyder 3 GigE Driver Manual**

## Driver Comparison

The performance metrics in Table 3 may help you determine which driver mode best suits your application requirements. The measurements were taken using an Intel P4 2.8 GHz-based PC with hyperthreading, 512 MB of memory, and Windows XP.

Although CPU performance and data transfer rates vary with PC configuration, relative performance is roughly equivalent, independent of the PC.

**Table 3: Driver Performance Comparison**

|                    | High-Performance IP Device Driver | Universal IP Filter Driver | Native Windows Stack |
|--------------------|-----------------------------------|----------------------------|----------------------|
| Maximum Throughput | 108 MB/s                          | 82 MB/s                    | 68 MB/s              |
| CPU Usage          | < 1%                              | < 15%                      | 50%                  |

With the hyper threading CPU used in these tests, the 50% CPU usage measured for the Native Windows stack indicates that one complete processing thread was employed to transfer the data. This leaves only one thread available for processing applications. By contrast, with the DALSA NetLink Universal IP Filter Driver and the DALSA NetLink High-Performance IP Device Driver, one complete thread and most of the second thread are available for applications processing.

## 2.4 Camera Connectors

The camera uses:

- An RJ-45 connector for Gigabit Ethernet signals, data signals, and serial communications. Refer to section 2.4.1 Ethernet Connector for details.
- One 6-pin Hirose connector for power. Refer to section 2.4.2 Power Connector for details.

- One 15-pin general purpose input/output (GPIO) connector. Refer to section 2.4.3 GPIO Connector for details.

**Figure 8: Spyder 3 GigE Input and Output Connectors**

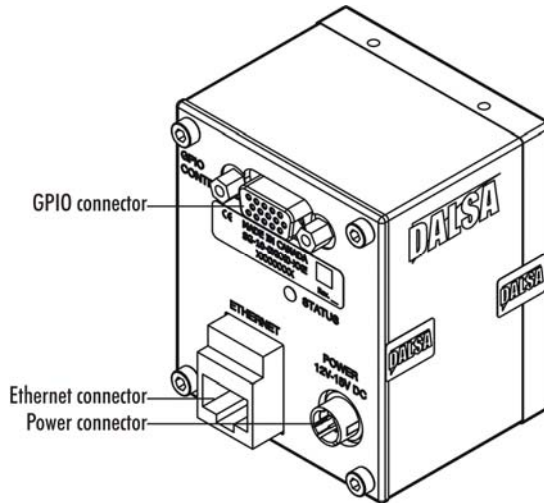

**WARNING:** It is extremely important that you apply the appropriate voltages to your camera. Incorrect voltages may damage the camera. See section 2.4 for more details.

## 2.4.1 Ethernet Connector

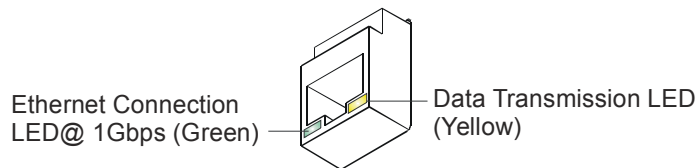

### Ethernet Connection LED

Steady green indicated that an Ethernet connection is successfully established at 1Gbps.

### Data Transmission LED

Steady yellow indicates that the camera is ready for data transmission.

Flashing yellow indicates that the camera is transmitting or receiving data.

### EMC Compliance

In order to achieve EMC compliance, the Spyder 3 camera requires the use of shielded CAT5e or CAT6 Ethernet cables.

## 2.4.2 Power Connector

**Figure 9: Hirose 6-pin Circular Male—Power Connector**

Hirose 6-pin Circular Male



**Table 4: Hirose Pin Description**

| Pin | Description         | Pin | Description |
|-----|---------------------|-----|-------------|
| 1   | Min +12 to Max +15V | 4   | GND         |
| 2   | Min +12 to Max +15V | 5   | GND         |
| 3   | Min +12 to Max +15V | 6   | GND         |

The camera requires a single voltage input (+12 to +15V). The camera meets all performance specifications using standard switching power supplies, although well-regulated linear supplies provide optimum performance.



**WARNING:** When setting up the camera's power supplies follow these guidelines:

- Apply the appropriate voltages
- Protect the camera with a **fast-blow fuse** between power supply and camera.
- Do not use the shield on a multi-conductor cable for ground.
- Keep leads as short as possible to reduce voltage drop.
- Use high-quality **linear** supplies to minimize noise.

**Note:** Camera performance specifications are not guaranteed if your power supply does not meet these requirements.

DALSA offers a power supply with attached 6' power cable that meets the Spyder 3 GigE camera's requirements, but it should not be considered the only choice. Many high quality supplies are available from other vendors. Visit the [www.dalsa.com](http://www.dalsa.com) Web site for a list of companies that make power supplies that meet the camera's requirements. The companies listed should not be considered the only choices.

## 2.4.3 GPIO Connector

The GPIO connector is used to control external signals. For example, the GPIO connector can be used to control EXSYNC, PRIN (pixel reset), and direction signals.

**Figure 10: GPIO Connector and Pin Numbers**

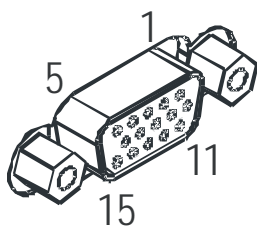

**Table 5: GPIO Connector Pinout**

| Pin | Signal   | Description                |
|-----|----------|----------------------------|
| 1   | INPUT_0+ | LVDS/TTL format (positive) |

| Pin | Signal    | Description  |
|-----|-----------|--|
| 2   | INPUT_0-  | Negative component when LVDS signal is arriving on Pin 1 |
| 3   | INPUT_1+  | LVDS/TTL format (positive)                               |
| 4   | INPUT_1-  | LVDS signal is arriving on Pin 3                         |
| 5   | GND       |  |
| 6   | INPUT_2+  | LVDS/TTL format (positive)                               |
| 7   | INPUT_2-  | LVDS signal  |
| 8   | INPUT_3   | TTL auxiliary input                                      |
| 9   | OUTPUT_3  | TTL auxiliary output                                     |
| 10  | OUTPUT_2+ | LVDS/TTL auxiliary output                                |
| 11  | OUTPUT_0+ | LVDS/TTL auxiliary output                                |
| 12  | OUTPUT_0- | LVDS negative component                                  |
| 13  | OUTPUT_1+ | LVDS/TTL auxiliary output                                |
| 14  | OUTPUT_1- | LVDS negative component                                  |
| 15  | OUTPUT_2- | LVDS negative component                                  |

A schematic of the TTL input circuitry is shown in Figure 11: TTL Input Schematic. The input signals are fed into the engine from external sources via the GPIO connector.

### TTL Inputs and Outputs

**Figure 11: TTL Input Schematic**

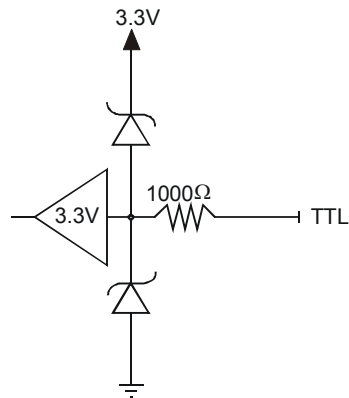

- Termination: 1000  $\Omega$  serial
- Input current: minimum 0 nA; maximum 2 mA
- Input voltage: maximum of low 0.9 V; minimum of high 2.1 V
- TTL inputs are 5V and 3.3V logic tolerant

**Figure 12: TTL Output Schematic**

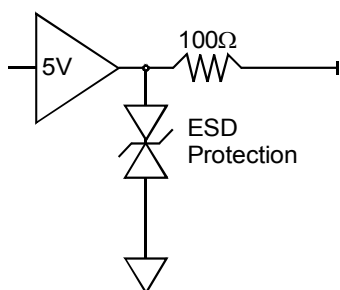

- Termination: 100 Ω serial
- Output current: sink 50 mA; source 50 mA
- Output voltage: maximum of low 0.44 V; minimum of high 2.48 V

*LVDS Inputs and Outputs*

**Figure 13: LVDS Input**

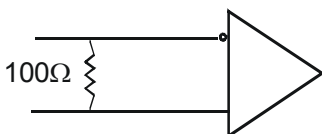

**Figure 14: LVDS Output**

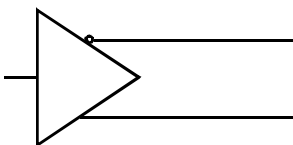

## Programming the GPIO Connector

The connector is programmed through the QuickCam application or through the QuickCam SDK. After you have installed the QuickCam program, refer to the QuickCam User's Manual or the QuickCam help topic, GPIO Control, for more information on programming the connector. Refer to section 3.1 QuickCam Interface for more information on installing QuickCam.

## 2.5 Camera LED

The camera is equipped with a red/green LED used to display the operational status of the camera. The table below summarizes the operating states of the camera and the corresponding LED states.

When more than one condition is active, the LED indicates the condition with the highest priority. Error and warning states are accompanied by corresponding messages further describing the current camera status.

**Table 6: Diagnostic LED**

| Priority | Color of Status LED | Meaning   |
|----------|---------------------|---|
| 1        | Flashing Red        | Fatal Error. For example, camera temperature is too |

| Priority | Color of Status LED | Meaning  |
|----------|---------------------|--|
| 1        | Flashing Red        | Camera initialization failed or camera thermal shutdown has occurred.  |
| 2        | Flashing Green      | Camera initialization or executing a long command (e.g., flat field correction commands <b>ccp</b> or <b>ccf</b> ) |
| 3        | Solid Green         | Camera is operational and functioning correctly  |

## 2.6 Camera Timing

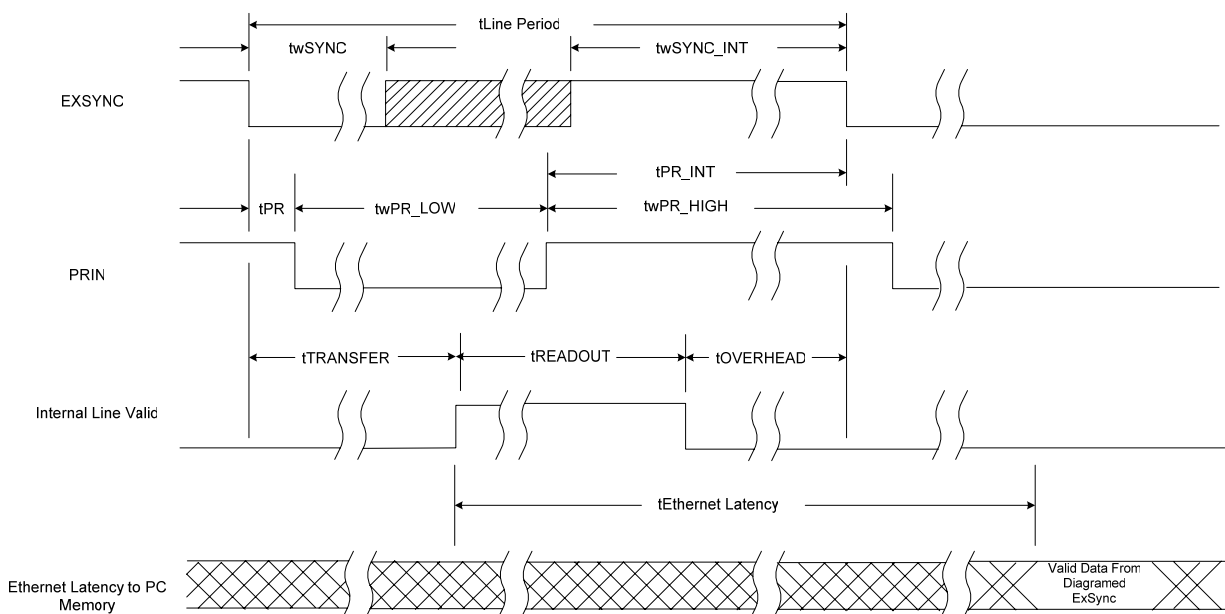

**Table 7: Camera Link Timing Parameter Table**

|                    | Units   | Min.           | Typ. | Max. | Notes  |
|--------------------|---------|----------------|------|------|--|
| $t_{Line\_Period}$ | $\mu s$ | 27.78          |      | 1000 | 1K 1 Tap   |
|                    |         | 14.71          |      | 1000 | 1K 2 Tap   |
|                    |         | 54.1           |      | 1000 | 2K 1 Tap   |
|                    |         | 27.78          |      | 1000 | 2K 2 Tap   |
| $t_{wSync}$        | ns      | 100            |      |      |  |
| $t_{wSYNCR\_INT}$  | ns      | 100<br>(3000*) |      |      | For exposure mode 4 this value needs to be >3000ns other wise >100ns |
| $t_{PR}$           | ns      | 0              |      |      |  |
| $t_{wPR\_LOW}$     | ns      | 3000           |      |      |  |
| $t_{wPR\_HIGH}$    | ns      | 3000           |      |      |  |
| $t_{PR\_INT}$      | ns      | 3000           |      |      |  |

**Table 8: tReadout Values**

| <b>tREADOUT</b> |        |              |
|-----------------|--------|--------------|
| Sensor Size     | # Taps | Readout Time |
| 1024            | 1      | 25600ns      |
| 1024            | 2      | 12800ns      |
| 2048            | 1      | 51200ns      |
| 2048            | 2      | 25600ns      |

**Table 9: tOverhead Values**

| tOVERHEAD   |        |              |
|-------------|--------|--------------|
| Sensor Size | # Taps | Readout Time |
| 1024        | 1      | 725ns        |
| 1024        | 2      | 450ns        |
| 2048        | 1      | 1400ns       |
| 2048        | 2      | 725ns        |

*Latency Calculation*

$$Latency = Ethernet\_Aquisition\_Time + LAN\_Preparation\_Time + LAN\_Transfer\_Time + Overhead\_Delay$$

**Ethernet Acquisition Time**

If pkt\_payload\_size equals line size use the following equation

$$Ethernet\_Acquisition\_Time = (pkt\_payload\_size / (clk\_freq * num\_taps * round\_up(pixel\_width / 8))) + (interline\_delay * INT(pkt\_payload\_size / line\_size))$$

If pkt\_payload\_size does not equal line size use the following equation

$$Ethernet\_Acquisition\_Time = (pkt\_payload\_size / (clk\_freq * num\_taps * round\_up(pixel\_width / 8)))$$

**Table 10**

|                      |          |                |
|----------------------|----------|----------------|
| pkt_payload_size     |          | 8128 (default) |
| pkt_header_size      |          | 64             |
| clk_freq (MHz)       |          | 40             |
| LAN_clk_freq (MHz)   |          | 33             |
| num_taps             |          | 1 or 2         |
| pixel_width          |          | 8 or 12        |
| interline_delay (µs) | 1k 1 tap | 1600           |
|                      | 1k 2 tap | 1325           |
|                      | 2k 1 tap | 2275           |
|                      | 2k 2 tap | 1600           |
| line_size            |          | 1024 or 2048   |

**LAN Preparation Time**

$$LAN\_Preparation\_Time = (pkt\_payload\_size + pkt\_header\_size) / (LAN\_clk\_freq * 4)$$

**LAN Transfer Time**

$$LAN\_Transfer\_Time = (pkt\_payload\_size + pkt\_header\_size) / 125MB/s$$

**Overhead Delay**

Overhead\_Delay can range from 5 to 6µs and is dependent upon the internal operations of your computer.



# 3

---

## Controlling the Camera

|  |           |
|--|-----------|
| <b>3.1 QuickCam Interface</b>                              | <b>32</b> |
| Installing and Running QuickCam and the QuickCam SDK ..... | 32        |
| Getting Help .....   | 32        |
| <b>3.2 Using ASCII Commands</b>                            | <b>33</b> |
| <b>3.4 First Power Up Camera Settings</b>                  | <b>35</b> |

**To control the Spyder 3 GigE camera, you have a choice of using:**

- The DALSA QuickCam graphical user interface (GUI). QuickCam provides you with a quick and easy way to start imaging with the camera. All camera functionality can be controlled with the QuickCam application. QuickCam is available on the Spyder 3 GigE CD. Refer to section 3.1 QuickCam Interface for instructions on installing and running QuickCam.
- The DALSA QuickCam SDK. All that is possible through QuickCam is also possible in custom built applications created through the Camera Interface Application SDK. You can also use the SDK to create a new camera specific interface. The SDK is available on the Spyder 3 GigE CD. Refer to section 3.1 QuickCam Interface for instructions on installing and running the QuickCam SDK
- ASCII commands. All of the camera's functionality is also accessible through its serial interface. Refer to section 3.2 Using ASCII Commands for more information on how to use ASCII commands,

## 3.1 QuickCam Interface

### Installing and Running the DALSA QuickCam GUI and the DALSA QuickCam SDK

If you have not already installed the DALSA QuickCam GUI, refer to section 2.1 Installation Overview for details on installing and running the software.

### Getting Help

The QuickCam application provides context-sensitive help on all dialog boxes, providing descriptions of specific fields as well as conceptual information related to those fields.

You can find help directly from the QuickCam Help or from the QuickCam User's Manual. Both are installed with the QuickCam application.

- For context sensitive help, place your cursor in the field where you want more help and press **F1**.

or

Click the **Help** button on the tab in QuickCam where you want more information.

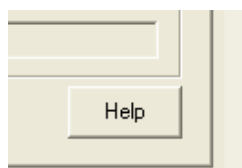

- For the complete Help, select **Help→QuickCam Help** on the QuickCam menu bar. You can find topics from the Help by using the table of contents and search tool.

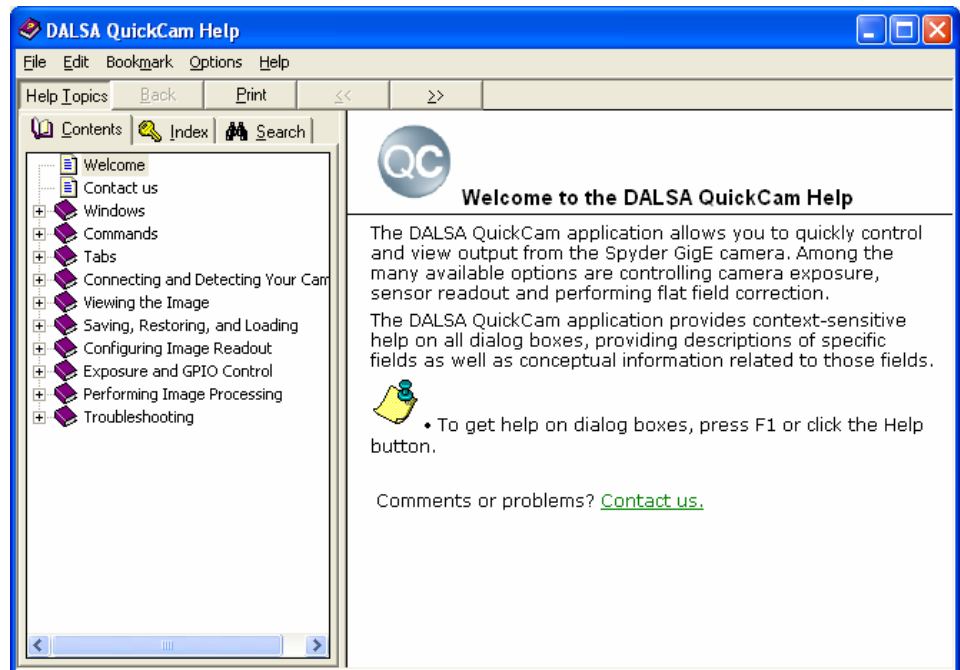

- To view the QuickCam User's Manual, point to **Programs → QuickCam → QuickCam User's Manual**

## 3.2 Using ASCII Commands

All functionality available through the QuickCam GUI is also available through the serial interface using the camera-specific three letter commands.

There are three ways to enter ASCII commands: through the QuickCam Command tab, through the Configuration window, or through the virtual serial port. Entering commands through the QuickCam Command window is the simplest method.

### Command Window Method:

1. Open QuickCam. Refer to section 3.1 QuickCam Interface for details on installing and running the application.

#### In the Message Window:

2. Open the **Command** tab.
3. At the **OK>** prompt, enter the ASCII command. Refer to Appendix A for details on all of the camera's available ASCII commands.
4. Press **Enter**.

The camera responds with **OK>** if the command was successful or an error or warning message as appropriate.

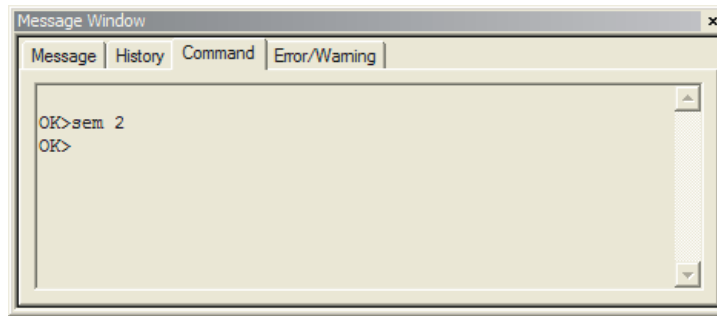
**Figure 15: Command Tab after Sending the sem (Set Exposure Mode) Command****Configuration Window Method:**

1. Open QuickCam. Refer to section 3.1 QuickCam Interface for details on installing and running the application.

In the **Camera Configuration Window**:

2. Open the **Exposure/GPIO tab**.
3. Click **Advanced...**
4. Open the **Port Communication tab**.

The Port Communication tab provides an ASCII interface. In order to comply with DALSA camera command protocol, you must send and receive as ASCII and ensure that the CR checkbox is checked (default).

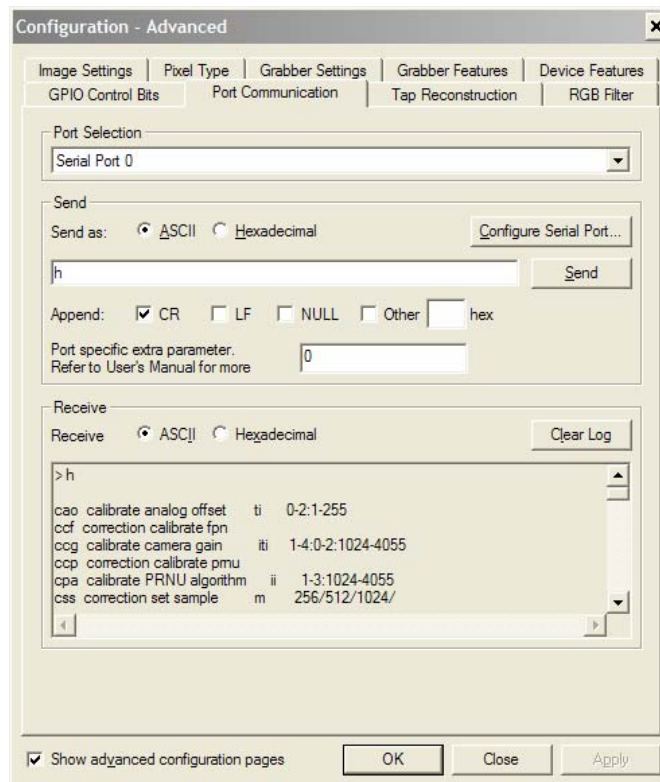
**Figure 16: Port Communication Tab after Sending the h (Help) Command**

### Virtual Serial Port Method

1. Open QuickCam. Refer to section 3.1 QuickCam Interface for details on installing and running the application.
2. Select **Configure** → **Virtual Serial Port** to enable or disable the virtual serial port.

Some camera control tools can connect only to a Windows system serial port. To avoid asking for changes from camera manufacturers, two serial COM ports in the PC can be linked together to share the serial channel to the IP engine. Through their linkage, data written to one port can be read by the other port, and vice-versa.

These linked serial COM ports can be either "virtual" or physical. To set up virtual ports, use a virtual serial port driver. Some good virtual serial port drivers are available at: <http://www.softinfinity.com/> or <http://www.virtual-serial-port.com/>.

Alternatively, if a PC has two free physical serial ports, they can be connected together and used as a pair, in the same manner as a virtual serial port driver.

The Serial Port Configuration dialog box allows you to attach the serial channel in QuickCam to one port in a serial port pair, whether a physical pair or virtual pair. Therefore, an external application needs simply to connect to the other serial port of the pair to communicate with the camera.

## 3.3 First Power Up Camera Settings

When the camera is powered up for the first time, it operates using the following factory settings:

- High sensitivity mode
- Forward CCD shift direction
- No binning
- Exposure mode 7 (Programmable line rate & max exposure time).
- 5000 Hz line rate
- Factory calibrated analog gain and offset
- Factory calibrated FPN and PRNU coefficients using the following process: line rate of 5000 Hz, analog gain calibrated to an average pixel value of 248 DN, fpn calibration, prnu calibration, 12 bit output, 9600 baud rate, exposure mode 2.

Notes: The FPN and PRNU coefficients are factory calibrated at a 5 kHz line rate and 0dB gain setting. While the factory setting baud rate is 9600, QuickCam sets the baud rate to 57600 at startup.



# 4

---

## Optical, Mechanical, and Electrical Considerations

*Chapter Contents*

|                                 |           |
|---------------------------------|-----------|
| <b>4.1 Mechanical Interface</b> | <b>38</b> |
| <b>4.2 Optical</b>              | <b>39</b> |
| Illumination .....              | 39        |
| Light Sources .....             | 39        |
| Filters .....                   | 39        |
| Lens Modeling .....             | 39        |
| Magnification .....             | 40        |
| <b>4.3 Electrical</b>           | <b>40</b> |

# 4.1 Mechanical Interface

**Figure 17: Spyder 3 GigE Camera Mechanical Dimensions**

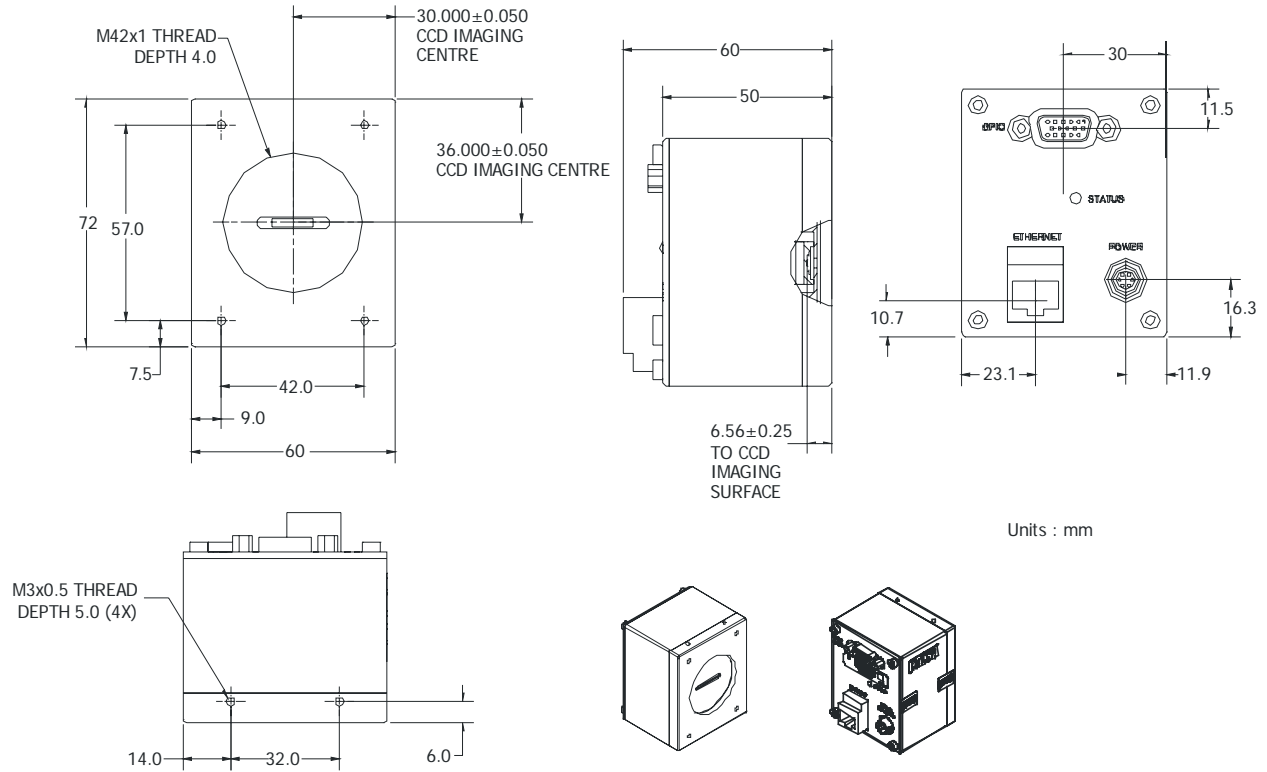

**Figure 18: Spyder 3 GigE Heatsink Mechanical Dimensions**

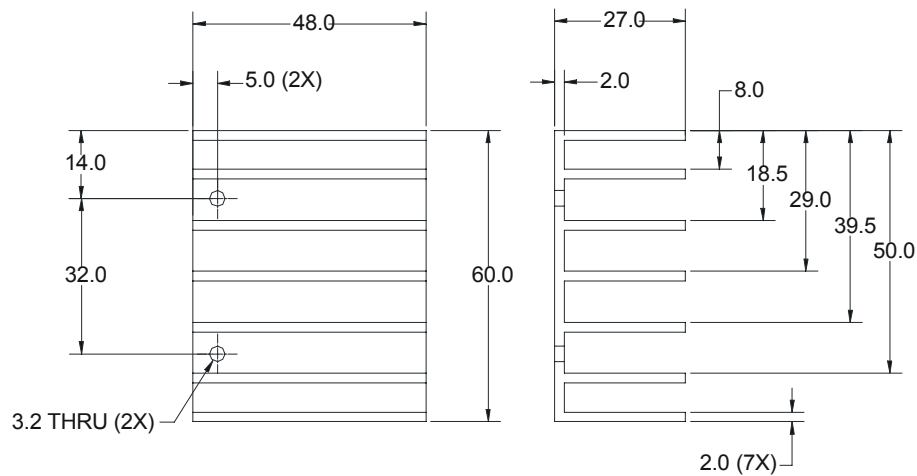

## 4.2 Optical Interface

### Illumination

The amount and wavelengths of light required to capture useful images depend on the particular application. Factors include the nature, speed, and spectral characteristics of objects being imaged, exposure times, light source characteristics, environmental and acquisition system specifics, and more. DALSA's Web site, <http://vfm.dalsa.com/>, provides an introduction to this potentially complicated issue. See "Radiometry and Photo Responsivity" and "Sensitivities in Photometric Units" in the CCD Technology Primer found under the Application Support link.

It is often more important to consider exposure than illumination. The total amount of energy (which is related to the total number of photons reaching the sensor) is more important than the rate at which it arrives. For example,  $5\mu\text{J}/\text{cm}^2$  can be achieved by exposing  $5\text{mW}/\text{cm}^2$  for 1ms just the same as exposing an intensity of  $5\text{W}/\text{cm}^2$  for  $1\mu\text{s}$ .

### Light Sources

Keep these guidelines in mind when setting up your light source:

- LED light sources are relatively inexpensive, provide a uniform field, and longer life span compared to other light sources. However, they also require a camera with excellent sensitivity, such as the Spyder 3 GigE camera.
- Halogen light sources generally provide very little blue relative to infrared light (IR).
- Fiber-optic light distribution systems generally transmit very little blue relative to IR.
- Some light sources age; over their life span they produce less light. This aging may not be uniform – a light source may produce progressively less light in some areas of the spectrum but not others.

### Filters

CCD cameras are extremely responsive to infrared (IR) wavelengths of light. To prevent infrared from distorting the images you scan, use a "hot mirror" or IR cutoff filter that transmits visible wavelengths but does not transmit wavelengths over 750nm. Examples are the Schneider Optics™ B+W 489, which includes a mounting ring, the CORION™ LS-750, which does not include a mounting ring, and the CORION™ HR-750 series hot mirror.

### Lens Modeling

Any lens surrounded by air can be modeled for camera purposes using three primary points: the first and second principal points and the second focal point. The primary points for a lens should be available from the lens data sheet or from the lens manufacturer. Primed quantities denote characteristics of the image side of the lens. That is,  $h$  is the object height and  $h'$  is the image height.

The *focal point* is the point at which the image of an infinitely distant object is brought to focus. The *effective focal length* ( $f'$ ) is the distance from the second principal point to the second focal point. The *back focal length* (BFL) is the distance from the image side of the lens surface to the second focal point. The *object distance* (OD) is the distance from the first principal point to the object.

**Figure 19: Primary Points in a Lens System**

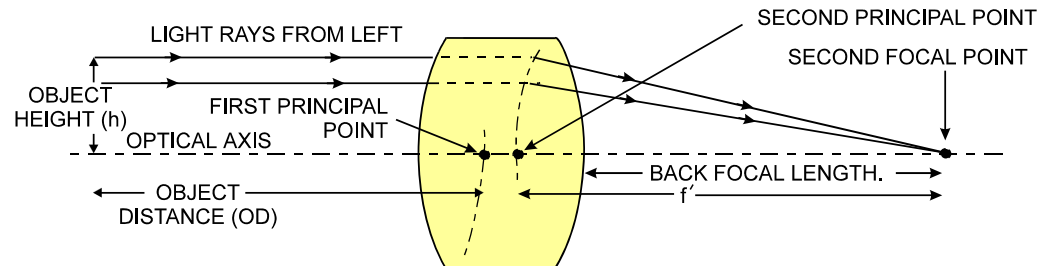

## Magnification and Resolution

The magnification of a lens is the ratio of the image size to the object size:

$$m = \frac{h'}{h} \quad \text{where } m \text{ is the magnification, } h' \text{ is the image height (pixel size) and } h \text{ is the object height (desired object resolution size).}$$

By similar triangles, the magnification is alternatively given by:

$$m = \frac{f'}{OD}$$

These equations can be combined to give their most useful form:

$$\frac{h'}{h} = \frac{f'}{OD} \quad \text{This is the governing equation for many object and image plane parameters.}$$

Example: An acquisition system has a 512 x 512 element, 10 $\mu$ m pixel pitch area scan camera, a lens with an effective focal length of 45mm, and requires that 100 $\mu$ m in the object space correspond to each pixel in the image sensor. Using the preceding equation, the object distance must be 450mm (0.450m).

$$\frac{10\mu\text{m}}{100\mu\text{m}} = \frac{45\text{mm}}{OD} \quad OD = 450\text{mm} (0.450\text{m})$$

## 4.3 Electrical Interface

The Spyder 3 GigE cameras have been designed for EMC compliance. The test setup has been verified to the following EMC standards:

- CISPR-11:2004
- EN 55011:2003
- EN 61326:2002

To achieve EMC compliance, follow these specific guidelines:

- Ensure that all cable shields have 360° electrical connection to the connector.
- Fasten and secure all connectors.

The EMC compliance is achieved with the use of shielded CAT5e or CAT6 Ethernet cables

## **Shielded cable suppliers**

The following is a partial list of cable suppliers carrying cables that meet the compliance requirements:

- <http://www.systemax.com/divisions.htm>
- <http://www.cablestogo.com>
- <http://www.globalsources.com>



# 5

---

## CCD Handling Instructions

### *Chapter Contents*

|   |           |
|---|-----------|
| <b>5.1 Electrostatic Discharge and the CCD Sensor</b> | <b>44</b> |
| <b>5.2 Protecting Against Dust, Oil and Scratches</b> | <b>44</b> |
| <b>5.3 Cleaning the Sensor Window</b>                 | <b>45</b> |

## 5.1 Electrostatic Discharge and the CCD Sensor

Cameras contain charge-coupled device (CCD) image sensors, which are metal oxide semiconductor (MOS) devices and are susceptible to damage from electrostatic discharge (ESD).

Electrostatic charge introduced to the sensor window surface can induce charge buildup on the underside of the window that cannot be readily dissipated by the dry nitrogen gas in the sensor package cavity. When charge buildup occurs, surface-gated photodiodes (SGPDs) may exhibit higher image lag. Some SGPD sensors, such as the IL-P4 and the IT-P4 used in the Spyder 3 GigE cameras, may also exhibit a highly non-uniform response when affected by charge buildup, with some pixels displaying a much higher response when the sensor is exposed to uniform illumination. The charge normally dissipates within 24 hours and the sensor returns to normal operation.



**WARNING: Charge buildup will affect the camera's flat-field correction calibration. To avoid an erroneous calibration, ensure that you perform flat-field correction only after a charge buildup has dissipated over 24 hours.**

## 5.2 Protecting Against Dust, Oil and Scratches

The CCD window is part of the optical path and should be handled like other optical components, with extreme care.

Dust can obscure pixels, producing dark patches on the sensor response. Dust is most visible when the illumination is collimated. The dark patches shift position as the angle of illumination changes. Dust is normally not visible when the sensor is positioned at the exit port of an integrating sphere, where the illumination is diffuse.

Dust can normally be removed by blowing the window surface using a compressed air blower, unless the dust particles are being held by an electrostatic charge, in which case either an ionized air blower or wet cleaning is necessary.

Oil is usually introduced during handling. Touching the surface of the window barehanded will leave oily residues. Using rubber fingercots and rubber gloves can prevent oil contamination. However, the friction between the rubber and the window may produce electrostatic charge that may damage the sensor. To avoid ESD damage and to avoid introducing oily residues, only hold the sensor from the edges of the ceramic package and avoid touching the sensor pins and the window.

Scratches can be caused by improper handling, cleaning or storage of the sensor. Vacuum picking tools should not come in contact with the window surface. CCDs should not be stored in containers where they are not properly secured and can slide against the container.

Scratches diffract incident illumination. When exposed to uniform illumination, a sensor with a scratched window will normally have brighter pixels adjacent to darker pixels. The location of these pixels changes with the angle of illumination.

## 5.3 Cleaning the Sensor Window

1. Use compressed air to blow off loose particles. This step alone is usually sufficient to clean the sensor window.
2. If further cleaning is required, use a lens wiper moistened with alcohol or acetone.
3. We recommend using lint-free ESD-safe cloth wipers that do not contain particles that can scratch the window. The Anticon Gold 9" x 9" wiper made by Milliken is both ESD safe and suitable for class 100 environments. Another ESD acceptable wiper is the TX4025 from Texwipe.
4. An alternative to ESD-safe cloth wipers is Transplex swabs that have desirable ESD properties. There are several varieties available from Texwipe. Do not use regular cotton swabs, since these can introduce charge to the window surface.
5. Wipe the window carefully and slowly.
6. When cleaning long linear sensors, it may be easier to wipe along the width (i.e. as opposed to the length) of the sensor.



# 6

---

## Troubleshooting

### *Chapter Contents*

|   |           |
|---|-----------|
| <b>6.1 Troubleshooting</b>                  | <b>48</b> |
| LED .....                                   | 48        |
| Connections.....                            | 48        |
| Cable Length/Type.....                      | 48        |
| Equipment Requirements .....                | 48        |
| Power Supply Voltages .....                 | 48        |
| EXSYNC .....                                | 48        |
| Camera Operation and Test Patterns .....    | 49        |
| Communications and Verify Parameters .....  | 49        |
| Verify Voltage .....                        | 49        |
| Verify Temperature.....                     | 49        |
| QuickCam Message Window .....               | 49        |
| Create an Error Report .....                | 49        |
| <b>6.2 Specific Solutions</b>               | <b>50</b> |
| No Output or Erratic Behavior .....         | 50        |
| Line Dropout.....                           | 50        |
| Noisy Output.....                           | 50        |
| Dark Patches.....                           | 50        |
| Horizontal Lines or Patterns in Image ..... | 51        |
| <b>6.3 Product Support</b>                  | <b>52</b> |

---

# 6.1 Troubleshooting

The information in this chapter can help you solve problems that may occur during the setup of your camera. Remember that the camera is part of the entire acquisition system. You may have to troubleshoot any or all of the following:

- power supplies
- Ethernet hardware & software
- light sources
- operating environment
- cabling
- host computer
- optics
- encoder

## LED

When the camera is first powered up, the LED will glow on the back of the camera. Refer to section 2.4.1 for information on the LED.

## Connections

The first step in troubleshooting is to verify that your camera has all the correct connections. Refer to section 2.4 Camera Connectors for more information on the proper connectors.

## Cable Length/Type

Ensure that cable lengths are no longer than 100m.

## Equipment Requirements

Ensure that you are using compatible equipment as outlined in section 2.2 Equipment Recommendations.

## Power Supply Voltages

Check for the presence of all voltages at the camera power connector. Verify that all grounds are connected. Refer to the Diagnostics tab in QuickCam to verify your voltage level.

## EXSYNC

When the camera is received from the factory, it defaults (no external input required) to exposure mode 7 (5000 Hz line rate, internal Sync to trigger readout). After a user has saved settings, the camera powers up with the saved settings.

If you change to an exposure mode that requires an external sync, ensure that you properly providing an external sync

## Camera Operation and Test Patterns

To validate camera and Ethernet connections, have the camera send out a test pattern and verify it is being properly received.

To send a test pattern:

Under **Test Pattern** on the **Diagnostics** tab in QuickCam:

1. Select a test pattern from the **Camera** dropdown box to confirm camera functionality
2. Select a test pattern from the **Ethernet** dropdown box to confirm your Ethernet connection.

## Communications and Verify Parameters

To quickly verify serial communications, check the **Diagnostics tab** in QuickCam. Communication is working properly if the camera settings are properly displayed in the **Camera Settings** section.

## Verify Voltage

To check the camera's input voltage, refer to the **Temperature/Voltage** section on the **Diagnostics tab** in QuickCam.

## Verify Temperature

To check the internal temperature of the camera, refer to the **Temperature/Voltage** section on the **Diagnostics tab** in QuickCam. The camera will shut itself down if the internal temperature exceeds 75°C.

## QuickCam Message Window

Refer to the Message Window in QuickCam for a list of messages sent from the camera and a list of all commands sent to the camera.

## Create an Error Report

You can create an error report in order to review test patterns and xml log files sent from the camera. This is useful for your own information as well as when you have to contact Product Support.

To create an error report:

1. Click the  button on QuickCam toolbar.  
In the **Save As** dialog box:
2. Select the location on your computer to save the file.
3. In the **File name** text box, enter a name for the error report.

4. Click **Save**.

**To view the error report:**

1. Select **View** → **Error Report**.

In the Open dialog box:

2. In the **Look in** list, click the drive or folder that contains the error report you want to open.
3. In the folder list, locate and open the folder that contains the error report.
4. Click the error report, and then click **Open**.

## 6.2 Specific Solutions

### No Output or Erratic Behavior

If your camera provides no output or behaves erratically, it may be picking up random noise from long cables acting as antennae. Do not attach wires to unused pins. Verify that the camera is not receiving spurious inputs (e.g. EXSYNC if camera is in exposure mode that requires external signals).

### Line Dropout, Bright Lines, or Incorrect Line Rate

Verify that the frequency of the internal sync is set correctly, or when the camera is set to external sync that the EXSYNC signal supplied to the camera does not exceed the camera's useable Line rate under the current operating conditions.

### Noisy Output

Check your power supply voltage outputs for noise. Noise present on these lines can result in poor video quality.

### Dark Patches

If dark patches appear in your output the optics path may have become contaminated. Clean your lenses and sensor windows with extreme care.

1. Take standard ESD precautions.
2. Wear latex gloves or finger cots
3. Blow off dust using a filtered blow bottle or dry, filtered compressed air.
4. Fold a piece of optical lens cleaning tissue (approx. 3" x 5") to make a square pad that
5. is approximately one finger-width
6. Moisten the pad on one edge with 2-3 drops of clean solvent—either alcohol or acetone. Do not saturate the entire pad with solvent.
7. Wipe across the length of the window in one direction with the moistened end first, followed by the rest of the pad. The dry part of the pad should follow the moistened

end. The goal is to prevent solvent from evaporating from the window surface, as this will end up leaving residue and streaking behind.

8. Repeat steps 2-4 using a clean tissue until the entire window has been cleaned.
9. Blow off any adhering fibers or particles using dry, filtered compressed air.

## **Horizontal Lines or Patterns in Image**

A faulty or irregular encoder signal may result in horizontal lines due to exposure time fluctuations; ensure that your exposure time is regular. If you have verified that your exposure time is consistent and patterns of low frequency intensity variations still occur, ensure that you are using a DC or high frequency light source.

## 6.3 Product Support

If there is a problem with your camera, collect the following data about your application and situation and call your DALSA representative.

**Note:** You may also want to photocopy this page to fax to DALSA.

|  |  |
|--|--|
| Customer name  |  |
| Organization name  |  |
| Customer phone number<br>fax number<br>email   |  |
| Complete Product Model Number<br>(e.g. SG-10-01k40...)                                       |  |
| Complete Serial Number   |  |
| Your DALSA Agent or Dealer   |  |
| Acquisition System hardware<br>(frame grabber, host computer,<br>light sources, etc.)        |  |
| Power supply setting and<br>current draw   |  |
| Data rate used   |  |
| Control signals used in your<br>application, and their frequency<br>or state (if applicable) | <input type="checkbox"/> EXSYNC <input type="checkbox"/> BIN<br><input type="checkbox"/> LVDS/TTL <input type="checkbox"/> Other _____ |
| Results when you run an error<br>report  | <i>please attach text received from the camera after initiating<br/>an error report</i>  |
| Detailed description of problem<br>encountered.  | <i>please attach description with as much detail as appropriate</i>  |

In addition to your local DALSA representative, you may need to call DALSA Technical Sales Support:

|               | North America     | Europe            | Asia              |
|---------------|-------------------|-------------------|-------------------|
| <b>Voice:</b> | 519-886-6000      | +49-8142-46770    | 519-886-6000      |
| <b>Fax:</b>   | 519-886-8023      | +49-8142-467746   | 519-886-8023      |
| <b>Email:</b> | support@dalsa.com | support@dalsa.com | support@dalsa.com |

# Appendix A

---

## Spyder 3 GigE ASCII Commands

### *Serial Protocol Defaults*

- 8 data bits
- 1 stop bit
- No parity
- No flow control
- 9.6kbps
- Camera does not echo characters

### *Command Format*

When entering commands, remember that:

- A carriage return <CR> ends each command.
- The camera will answer each command with either <CR><LF> "OK >" or <CR><LF>"Error xx: Error Message >" or "Warning xx: Warning Message". The ">" is always the last character sent by the camera.

The following parameter conventions are used in the manual:

- *i* = integer value
- *f* = real number
- *m* = member of a set
- *s* = string
- *t* = tap id
- *x* = pixel column number
- *y* = pixel row number

### **Example: to return the current camera settings**

```
gcp <CR>
```

## Setting Baud Rate

|                  |   |
|------------------|---|
| Purpose:         | Sets the speed in bps of the serial communication port.   |
| Syntax:          | <code>sbr m</code>  |
| Syntax Elements: | <code>m</code>  |
|                  | Baud rate. Available baud rates are: <b>9600</b> (Default), <b>19200</b> , <b>57600</b> , and <b>115200</b> .   |
| Notes:           | <ul style="list-style-type: none"> <li>• Power-on rate is always 9600 baud.</li> <li>• The <a href="#">rc</a> (reset camera) command will <i>not</i> reset the camera to the power-on baud rate and will reboot using the last used baud rate.</li> </ul> |
| Example:         | <code>sbr 57600</code>  |

## Camera ASCII Command Help

For quick help, the camera can return all available commands and parameters through the serial interface.

There are two different help screens available. One lists all of the available commands to configure camera operation. The other help screen lists all of the commands available for retrieving camera parameters (these are called “get” commands).

**To view the help screen listing all of the camera configuration commands, use the command:**

Syntax: `h`

**To view a help screen listing all of the “get” commands, use the command:**

Syntax: `gh`

Notes: For more information on the camera’s “get” commands, refer to section A4.7 Returning Camera Settings.

The camera configuration command help screen lists all commands available. Parameter ranges displayed are the extreme ranges available. Depending on the current camera operating conditions, you may not be able to obtain these values. If this occurs, values are clipped and the camera returns a warning message.

Some commands may not be available in your current operating mode. The help screen displays NA in this case.

### Example ASCII Command Help Screen (1k 2 Tap Model)

|  |
|--|
| <p>Parameters<br/> i = integer<br/> f = floating point number<br/> m = member of a set<br/> s = string<br/> t = tap<br/> x = pixel column number<br/> y = pixel row number</p> |
|--|

```

cao  calibrate analog offset      ti      0-2:1-255
ccf  correction calibrate fpn
ccg  calibrate camera gain       iti     1-4:0-2:1024-4055
ccp  correction calibrate prnu
cpa  calibrate PRNU algorithm     ii      1-3:1024-4055
css  correction set sample        m       256/512/1024/
dgc  display gpio configuration
dpc  display pixel coeffs         xx      1-1024:1-1024
els  end of line sequence         i       0-1
epc  enable pixel coefficients     ii      0-1:0-1
gcm  get camera model
gcp  get camera parameters
gcs  get camera serial
gcv  get camera version
get  get values                   s
gfc  get fpn coeff                x       1-1024
gh   get help
gl   get line                     xx      1-1024:1-1024
gla  get line average             xx      1-1024:1-1024
gpc  get prnu coeff              x       1-1024
gsf  get signal frequency         i       1-4
gsl  get status led
h    help
lpc  load pixel coefficients       i       0-4
rc   reset camera
rfs  restore factory settings
roi  region of interest           xyxy    1-1024:1-1:1-1024:1-1
rpc  reset pixel coeffs
rus  restore user settings
sag  set analog gain             tf      0-2:-10.0-+10.0
sao  set analog offset           ti      0-2:0-255
sbh  set binning horizontal       m       1/2/
sbr  set baud rate               m       9600/19200/57600/115200/
scd  set ccd direction            i       0-2
sdm  set data mode               m       2/3
sdo  set digital offset          ti      0-2:0-2048
sem  set exposure mode           m       2/3/4/5/6/7/8/
set  set exposure time           f       3-1000
sfc  set fpn coeff               xi      1-1024:0-2047
sgi  set gpio input              ii      0-3:0-2
sgo  set gpio output             ii      0-3:0-2
slt  set lower threshold         i       0-4095
spc  set prnu coeff              xi      1-1024:0-28671
srm  set readout mode            i       0-2
ssb  set subtract background      ti      0-2:0-4095
ssf  set sync frequency          f       300-68000
ssg  set system gain             ti      0-2:0-65535
ssm  set sensitivity mode        i       0-2
sut  set upper threshold         i       0-4095
svm  set video mode              i       0-2
ugr  update gain reference
vt   verify temperature
vv   verify voltage
wfc  write FPN coefficients       i       1-4
wpc  write PRNU coefficients     i       1-4
wus  write user settings
    
```

# A1 Sensor Output Format

## A1.1 Sensitivity Mode

|                  |  |
|------------------|--|
| Purpose:         | Sets the camera's sensitivity mode. When using high sensitivity mode, the camera's responsivity increases. High sensitivity mode permits much greater scanning speeds in low light, or allows reduced lighting levels.   |
| Syntax:          | <code>ssm i</code>   |
| Syntax Elements: | <code>i</code><br>Sensitivity mode to use.<br>0 = Low sensitivity mode<br>1 = High sensitivity mode<br>2 = Tall pixel mode   |
| Notes:           | <ul style="list-style-type: none"> <li>To obtain the current sensitivity mode, use the command <a href="#">gcp</a> or <a href="#">get ssm</a>.</li> <li>The <code>scd</code> (set ccd direction) command is not available in low sensitivity mode or tall pixel mode.</li> </ul> |
| Example:         | <code>ssm 0</code>   |

## A1.2 CCD Shift Direction

|                   |   |
|-------------------|---|
| Purpose:          | When in high sensitivity mode, selects the forward or reverse CCD shift direction or external direction control. This accommodates object direction change on a web and allows you to mount the camera "upside down".   |
| Syntax:           | <code>scd i</code>  |
| Syntax Elements:  | <code>i</code><br>Shift direction. Allowable values are:<br>0 = Forward CCD shift direction.<br>1 = Reverse CCD shift direction.<br>2 = Externally controlled direction control via Camera Link control CC3 (CC3=1 forward, CC3=0 reverse).   |
| Notes:            | <ul style="list-style-type: none"> <li>To obtain the current value of the exposure mode, use the command <a href="#">gcp</a> or <a href="#">get scd</a>.</li> <li>Available in high sensitivity mode only.</li> <li>Refer to Figure 6: Object Movement and Camera Direction Example using an Inverting Lens for an illustration of when you should use forward or reverse shift direction.</li> </ul> |
| Related Commands: | <a href="#">ssm</a>   |
| Example:          | <code>scd 0</code>  |

## A1.3 Setting the Bit Depth and Data Mode

|                  |  |
|------------------|--|
| Purpose:         | Selects the camera's bit depth, number of taps, and data rate. |
| Syntax:          | <b>sdm i</b>   |
| Syntax Elements: | <b>i</b>   |
|                  | Camera bit depth. Allowable values are:                        |
|                  | <i>For SG-10-01K40 and SG-10-02K40</i>                         |
|                  | <b>0</b> = 8 bits, 1 tap, 40MHz data rate                      |
|                  | <b>1</b> = 12 bits, 1 tap, 40MHz data rate                     |
|                  | <i>For SG-10-01K80 and SG-10-02K80</i>                         |
|                  | <b>2</b> = 8 bits, 2 taps, 80Mhz data rate                     |
|                  | <b>3</b> = 12 bits, 2 taps, 80MHz data rate                    |
| Example:         | <b>sdm 0</b>   |

## A1.4 Exposure Mode, Readout Mode, Line Rate and Exposure Time

### Overview

You have a choice of operating in one of seven modes. The camera's line rate (synchronization) can be generated internally through the software command **ssf** or set externally with an EXSYNC signal, depending on your mode of operation. To select how you want the camera's line rate to be generated:

1. You must first set the camera mode using the [sem](#) command.
2. Next, if using mode 2, 7 or 8 use the commands [ssf](#) and/or [set](#) to set the line rate and exposure time.

### Setting the Exposure Mode

|                   |   |
|-------------------|---|
| Purpose:          | Sets the camera's exposure mode allowing you to control your sync, exposure time, and line rate generation.   |
| Syntax:           | <b>sem i</b>  |
| Syntax Elements:  | <b>i</b>  |
|                   | Exposure mode to use. Factory setting is 7.   |
| Notes:            | <ul style="list-style-type: none"> <li>• Refer to Table 11: Spyder 3 GigE Exposure Modes for a quick list of available modes or to the following sections for a more detailed explanation.</li> <li>• To obtain the current value of the exposure mode, use the command <a href="#">gcp</a> or <b>get sem</b>.</li> </ul> |
| Related Commands: | <a href="#">ssf</a> , <a href="#">set</a>   |
| Example:          | <b>sem 3</b>  |

**Table 11: Spyder 3 GigE Exposure Modes**

| Mode | Programmable Line Rate |          | Programmable Exposure Time |     | Description   |
|------|------------------------|----------|----------------------------|-----|---|
|      | SYNC                   | PRIN     | ↓                          | ↓   |   |
| 2    | Internal               | Internal | Yes                        | Yes | Internal frame rate and exposure time. Exposure mode enabled (ECE). |
| 3    | External               | Internal | No                         | No  | Maximum exposure time. Exposure control disabled (ECD).             |
| 4    | External               | Internal | No                         | No  | Smart EXSYNC. ECE.  |
| 5    | External               | External | No                         | No  | External sync, external pixel reset. ECE.                           |
| 6    | External               | Internal | No                         | Yes | Fixed integration time. ECE.  |
| 7    | Internal               | Internal | Yes                        | No  | Internal line rate, maximum exposure time. ECD.                     |
| 8    | Internal               | Internal | No                         | Yes | Maximum line rate for exposure time. ECE.                           |

**Note:** When setting the camera to external signal modes, EXSYNC and/or PRIN must be supplied.

### Exposure Modes in Detail

#### Mode 2: Internally Programmable Line Rate and Exposure Time (Factory Setting)

Mode 2 operates at a maximum line rate and exposure time.

- When setting the line rate (using the [ssf](#) command), exposure time will be reduced, if necessary, to accommodate the new line rate. The exposure time will always be set to the maximum time (line period – line transfer time – pixel reset time) for that line rate when a new line rate requiring reduced exposure time is entered.
- When setting the exposure time (using the [set](#) command), line time will be increased, if necessary, to accommodate the exposure time. Under this condition, the line time will equal the exposure time + line transfer time.

#### Example 1: Exposure Time less than Line Period

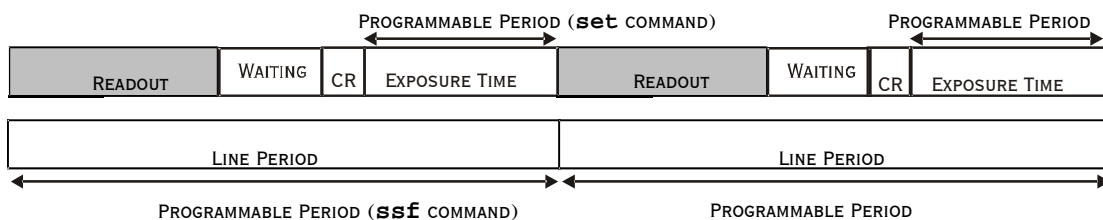

CR=CHARGE RESET

### Mode 3: External Trigger with Maximum Exposure

Line rate is set by the period of the external trigger pulses. The falling edge of the external trigger marks the beginning of the exposure.

#### Example 2: Line Rate is set by External Trigger Pulses.

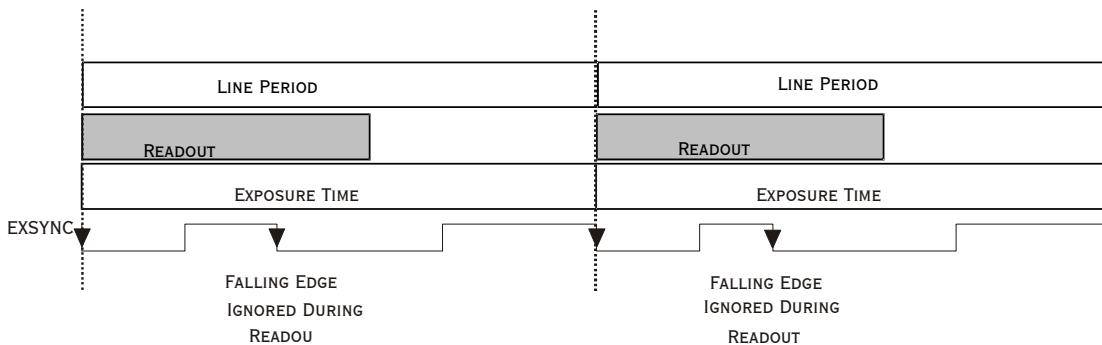

### Mode 4: Smart EXSYNC, External Line Rate and Exposure Time

In this mode, EXSYNC sets both the line period and the exposure time. The rising edge of EXSYNC marks the beginning of the exposure and the falling edge initiates readout.

#### Example 3: Trigger Period is Repetitive and Greater than Read Out Time.

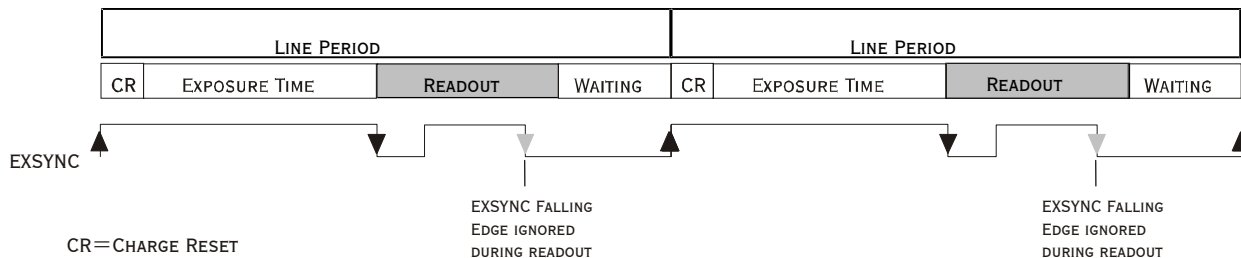

### Mode 5: External Line Rate (EXSYNC) and External Pixel Reset (PRIN)

In this mode, the falling edge of EXSYNC sets the line period and the rising edge of PRIN sets the start of exposure time.

Figure 20: EXSYNC controls Line Period and PRIN controls Exposure Time

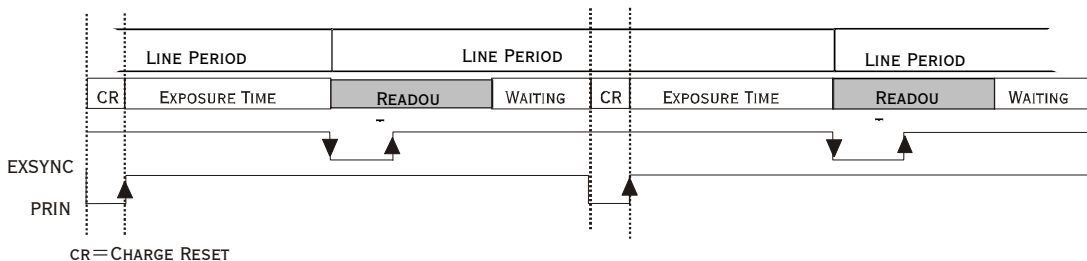

**Mode 6: External Line Rate and Internally Programmable Exposure Time**

**Figure 21: EXSYNC controls Line Period with Internally controlled Exposure Time**

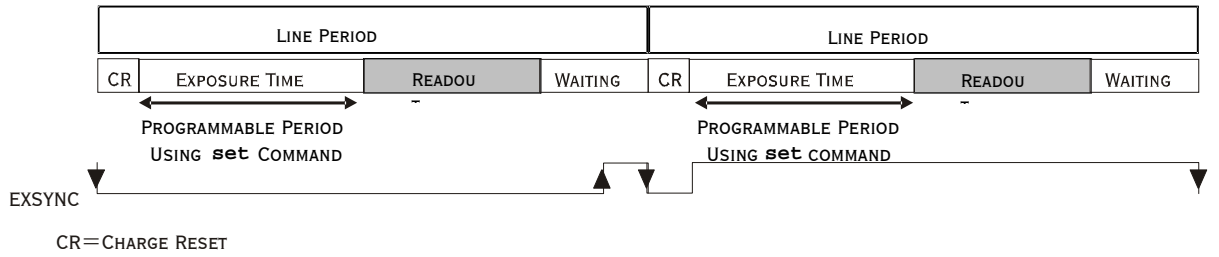

**Mode 7: Internally Programmable Line Rate, Maximum Exposure Time**

In this mode, the line rate is set internally with a maximum exposure time.

**Figure 22: Mode 7 Camera Timing**

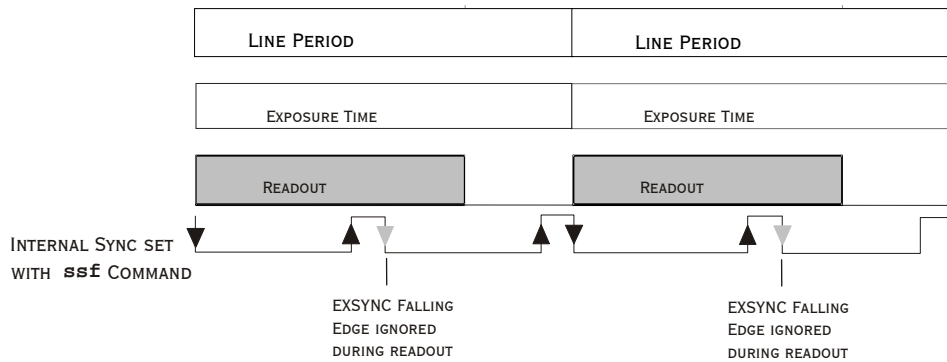

**Mode 8: Maximum Line Rate, Programmable Exposure Time**

In this mode, the exposure time is set internally with a maximum line rate.

**Figure 23: Mode 8 Timing**

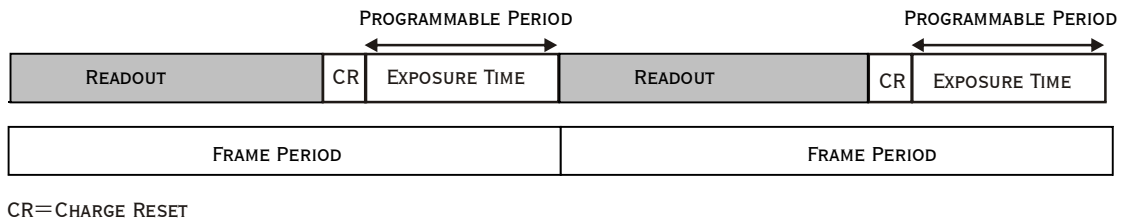

## Setting the Readout Mode

See also, Appendix C: Clearing Dark Current for more information on this mode.

|                   |  |
|-------------------|--|
| Purpose:          | Use this command to clear out dark current charge in the vertical transfer gates immediately before the sensor is read out.  |
| Syntax:           | <b>srm</b>   |
| Syntax Elements:  | <b>i</b>   |
|                   | <p><b>0:</b> Auto. Clears dark current below ~ 45% of the maximum line rate.</p> <p><b>1:</b> Dark current clear. Always clears dark. Reduces the maximum line rate.</p> <p><b>2:</b> Immediate readout. Does not clear dark current. (Default mode.)</p>  |
| Notes:            | <ul style="list-style-type: none"> <li>• The vertical transfer gates collect dark current during the line period. This collected current is added to the pixel charge. The middle two red taps have more vertical transfer gates and, therefore, more charge. This additional charge is especially noticeable at slower line rates.</li> <li>• If the user is in <b>sem 2</b> or <b>7</b> and <b>srm 2</b>, with <b>ssf</b> at 45% of the maximum, and then <b>srm 1</b> is selected, the following warning will be displayed, but the <b>ssf</b> value will not be changed:<br/>Warning 09: Internal line rate inconsistent with readout time&gt;<br/>The effect in both internal and external line rate modes is that an EXSYNC is skipped and, therefore, the output will be at least twice as bright.</li> <li>• This value is saved with the camera settings.</li> <li>• This value may be viewed using either the <b>gcp</b> command or the get <b>srm</b> command.</li> </ul> |
| Related Commands: | <b>sem, ssf</b>  |
| Example:          | <b>srm 0</b>   |



Applies to Modes 2 and 7

## Setting the Line Rate

**Purpose:** Sets the camera's line rate in Hz. Camera must be operating in exposure mode 2 or 7.

**Syntax:** `ssf f`

**Syntax Elements:** `i`

Desired line rate in Hz. Allowable values are:

1k 1 tap: 300-36000 Hz

1k 2 tap: 300-68000 Hz

2k 1 tap: 300-18500 Hz

2k 2 tap: 300-36000 Hz

**Notes:**

- To read the current line frequency, use the command [gcp](#) or [get ssf](#).
- If you enter an invalid line rate frequency, an error message is returned.

**Related Commands:** [sem](#), [set](#)

**Example:** `ssf 10000`



Applies to Modes 2 and 8

## Setting the Exposure Time

**Purpose:** Sets the camera's exposure time in  $\mu$ s. Camera must be operating in mode 2, 6, or 8.

**Syntax:** `set f`

**Syntax Elements:** `i`

Desired exposure time in  $\mu$ s. Allowable range is 3 to 3300 $\mu$ s.\*

**Notes:**

- To read the current line frequency, use the command [gcp](#) or [get set](#).
- If you enter an invalid line rate frequency, an error message is returned.
- \*The exposure time range is based on the current line rate.
- To determine the maximum exposure time allowed for the current line rate, use the command [get ger](#).

**Related Commands:** [sem](#), [ssf](#)

**Example:** `set 400.5`

## A1.5 Configuring the GPIO Connector

### Overview

The following commands provide a connection between the GPIO controller and the Spyder 3 GigE camera's internal functions.

```
sgd p i
p
i
,
sgd 0 0
```

### Setting the GPIO Output Signal

Purpose: Sets the signal type for the selected output.

Syntax: **sgo i i**

Syntax Elements: **i**

Output to set.

0 = Output 0, pin 11 (TTL) or 11 and 12 (LVDS)

1 = Output 1, pin 13 (TTL) or 13 and 14 (LVDS)

2 = Output 2, pin 15 (TTL) or 15 and 10 (LVDS)

3 = Output 3, pin 9 (TTL)

**i**

Signal type.

0 = High impedance (high z)

1 = TTL

2 = LVDS

Notes:

- To read the current configuration, use the command **dgc** or **get sgo i** where **i** is the output signal.
- If you enter an invalid configuration, an error message is returned.

Related Commands: [sgi](#)

Example: **sgo 0 1**

## Setting the GPIO Input Signal

|                   |   |
|-------------------|---|
| Purpose:          | Sets the signal type for the selected input.  |
| Syntax:           | <code>sgi i i</code>  |
| Syntax Elements:  | <p><code>i</code></p> <p>Input to set.</p> <p>0 = Input 0, Pin 1 (TTL) or 1 and 2 (LVDS)<br/> 1 = Input 1, Pin 3 (TTL) or 3 and 4 (LVDS)<br/> 2 = Input 2, Pin 6 (TTL) or 6 and 7 (LVDS)<br/> 3 = Input 3, Pin 8 (TTL)</p> <p><code>i</code></p> <p>Signal type.</p> <p>0 = Disabled<br/> 1 = TTL<br/> 2 = LVDS</p> |
| Notes:            | <ul style="list-style-type: none"> <li>To read the current configuration, use the command <code>dgc</code> or <code>get sgi i</code> where <code>i</code> is the input signal.</li> <li>If you enter an invalid configuration, an error message is returned.</li> </ul>   |
| Related Commands: | <a href="#">sgo</a>   |
| Example:          | <pre>sgi 3 1  sgs p i  p i  sgs 0 0</pre>   |

## A2 Data Processing

### A2.1 Setting a Region of Interest (ROI)

|                  |  |
|------------------|--|
| Purpose:         | <p>Sets the pixel range used to collect the end-of-line statistics and sets the region of pixels used in the <a href="#">ccg</a>, <a href="#">cao</a>, <a href="#">gl</a>, <a href="#">gla</a>, <a href="#">ccf</a>, and <a href="#">ccp</a> commands.</p> <p>In most applications, the field of view exceeds the required object size and these extraneous areas should be ignored. It is recommended that you set the region of interest a few pixels inside the actual useable image.</p>             |
| Syntax:          | <code>roi x1 y1 x2 y2</code>   |
| Syntax Elements: | <p><b>x1</b></p> <p>Pixel start number. Must be less than the pixel end number in a range from 1 to <b>sensor resolution</b>.</p> <p><b>y1</b></p> <p>Column start number. Since the Spyder 3 GigE is a line scan camera, this value must be 1.</p> <p><b>x2</b></p> <p>Pixel end number. Must be greater than the pixel start number in a range from 1 to <b>sensor resolution</b>.</p> <p><b>y2</b></p> <p>Column end number. Since the Spyder 3 GigE is a line scan camera, this value must be 1.</p> |
| Notes:           | <ul style="list-style-type: none"> <li>To return the current region of interest, use the commands <a href="#">gcp</a> or <a href="#">get roi</a>.</li> </ul>   |
| Related Commands | <a href="#">ccg</a> , <a href="#">cao</a> , <a href="#">gl</a> , <a href="#">gla</a> , <a href="#">ccf</a> , <a href="#">ccp</a> , <a href="#">cpa</a> , <a href="#">els</a>   |
| Example:         | <code>roi 10 1 50 1</code>   |

## A2.2 Analog and Digital Signal Processing Chain

### Processing Chain Overview and Description

The following diagram shows a simplified block diagram of the camera's analog and digital processing chain. The analog processing chain begins with an analog gain adjustment, followed by an analog offset adjustment. These adjustments are applied to the video analog signal prior to its digitization by an A/D converter.

The digital processing chain contains the FPN correction, the PRNU correction, the background subtract, and the digital gain and offset. All of these elements are user programmable.

Figure 24: Signal Processing Chain

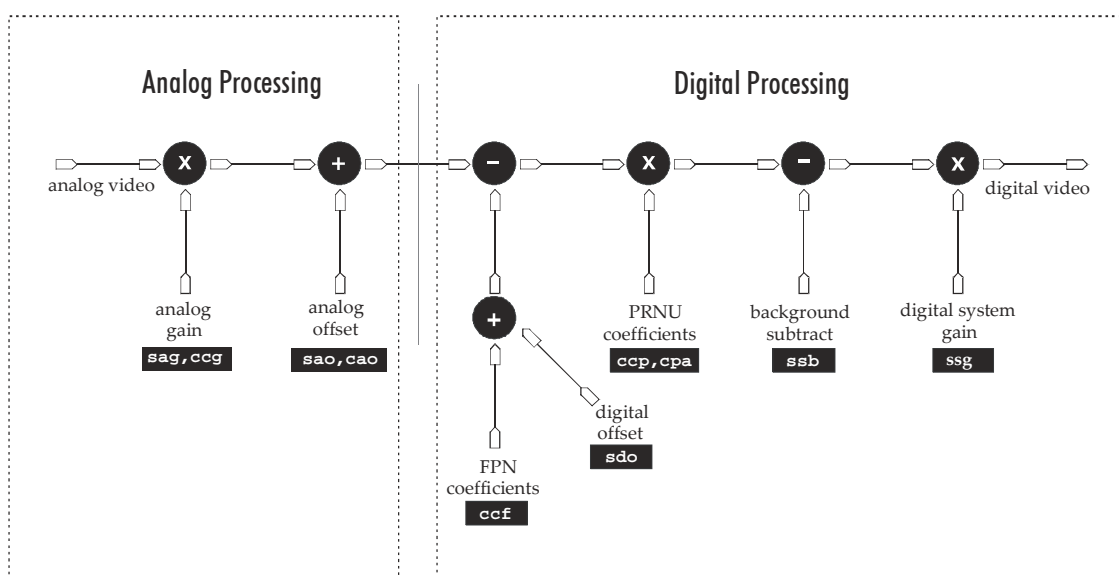

#### Analog Processing

Optimizing offset performance and gain in the analog domain allows you to achieve a better signal-to-noise ratio and dynamic range than you would achieve by trying to optimize the offset in the digital domain. As a result, perform all analog adjustments prior to any digital adjustments.

1. Analog gain ([sag](#) or [ccg](#) command) is multiplied by the analog signal to increase the signal strength before the A/D conversion. It is used to take advantage of the full dynamic range of the A/D converter. For example, in a low light situation the brightest part of the image may be consistently coming in at only 50% of the DN. An analog gain of 6 dB (2x) will ensure full use of the dynamic range of the A/D converter. Of course the noise is also increased.
2. The analog offset ([sao](#) or [cao](#) command) or black level is an “artificial” offset introduced into the video path to ensure that the A/D is functioning properly. The analog offset should be set so that it is at least 3 times the rms noise value at the current gain.

#### Digital Processing

To optimize camera performance, digital signal processing should be completed after any analog adjustments.

1. Fixed pattern noise (FPN) calibration (calculated using the [ccf](#) command) is used to subtract away individual pixel dark current.
2. The digital offset ([sdo](#) command) enables the subtraction of the “artificial” A/D offset (the analog offset) so that application of the PRNU coefficient doesn't result in artifacts at low light levels due to the offset value. You may want to set the [sdo](#) value if you are not using FPN correction but want to perform PRNU correction.
3. Photo-Response Non-Uniformity (PRNU) coefficients (calculated using the [ccp](#) or [cpa](#) commands) are used to correct the difference in responsivity of individual pixels (i.e. given the same amount of light different pixels will charge up at different rates) and the change in light intensity across the image either because of the light source or due to optical aberrations (e.g. there may be more light in the center of the image). PRNU coefficients are multipliers and are defined to be of a value greater than or equal to 1. This ensures that all pixels will saturate together.
4. Background subtract ([ssb](#) command) and system (digital) gain ([ssg](#) command) are used to increase image contrast after FPN and PRNU calibration. It is useful for systems that process 8-bit data but want to take advantage of the camera's 12 bit digital processing chain. For example, if you find that your image is consistently between 128 and 255DN(8 bit), you can subtract off 128 ([ssb 2048](#)) and then multiply by 2 ([ssg 0 8192](#)) to get an output range from 0 to 255.

## Analog Signal Processing: Setting Analog Gain and Offset

All analog signal processing chain commands should be performed prior to FPN and PRNU calibration and prior to digital signal processing commands.

### Setting Analog Gain

|                   |   |
|-------------------|---|
| Purpose:          | Sets the camera's analog gain value. Analog gain is multiplied by the analog signal to increase the signal strength before the A/D conversion. It is used to take advantage of the full dynamic range of the A/D converter. |
| Syntax:           | <b>sag t f</b>  |
| Syntax Elements:  | <b>t</b><br>Tap selection. Use <b>0</b> for all taps or <b>1</b> to <b>2</b> for individual tap selection.<br><b>f</b><br>Gain value in a range from <b>-10</b> to <b>+10dB</b> .   |
| Notes:            | <ul style="list-style-type: none"> <li>• To return the current analog gain setting, use the command <a href="#">gcp</a> or <a href="#">get sag</a>.</li> </ul>  |
| Example:          | <b>sag 0 5.2</b>  |
| Related Commands: | <a href="#">ccg</a>   |

### Calibrating Camera Gain

|                   |  |
|-------------------|--|
| Purpose:          | Instead of manually setting the analog gain to a specific value, the camera can determine appropriate gain values. This command calculates and sets the analog gain according to the algorithm determined by the first parameter.  |
| Syntax:           | <code>ccg i t i</code>   |
| Syntax Elements:  | <p><b>i</b></p> <p>Calibration algorithm to use.</p> <p><b>1</b> = This algorithm adjusts analog gain so that 8% to 13% of tap region of interest (ROI) pixels are above the specified target value.</p> <p><b>2</b> = This algorithm adjusts analog gain so that the average pixel value in tap's ROI is equal to the specified target value.</p> <p><b>3</b> = This algorithm adjusts digital gain so that the average pixel value in tap's ROI is equal to the specified target.</p> <p><b>4</b> = This algorithm adjusts the analog gain so that the peak tap ROI pixels are adjusted to the specified target.</p> <p><b>t</b></p> <p>Tap value. Use <b>0</b> for all taps or <b>1</b> to <b>2</b> for individual tap selection if you are using the two tap model.</p> <p><b>i</b></p> <p>Calculation target value in a range from <b>1024</b> to <b>4055DN</b> (12 bit LSB).</p> |
| Notes:            | <ul style="list-style-type: none"> <li>• This function requires constant light input while executing.</li> <li>• If very few tap pixels are within the ROI, gain calculation may not be optimal.</li> <li>• When all taps are selected, taps outside of the ROI are set to the average gain of the taps that are within the ROI.</li> <li>• Perform analog gain algorithms before performing FPN and PRNU calibration.</li> <li>• All digital settings affect the analog gain calibration. If you do not want the digital processing to have any effect on the camera gain calibration, then turn off all digital settings by sending the commands: <code>sdo 0 0</code>, <code>epc 0 0</code>, <code>ssb 0 0</code>, and <code>ssg 0 4096</code></li> </ul>   |
| Example:          | <code>ccg 2 0 3040</code>  |
| Related Commands: | <code>sag</code> , <code>ssg</code>  |

### *Setting Analog Offset*

|                   |   |
|-------------------|---|
| Purpose:          | Sets the analog offset. The analog offset should be set so that it is at least 3 times the rms noise value at the current gain. DALSA configures the analog offset for the noise at the maximum specified gain and as a result you should not need to adjust the analog offset. |
| Syntax:           | <code>sao t i</code>  |
| Syntax Elements:  | <p><code>t</code></p> <p>Tap selection. Use <b>0</b> for all taps or <b>1 to 2</b> for individual tap selection if you are using the two tap model.</p> <p><code>i</code></p> <p>Offset value in a range from <b>0</b> to <b>255DN</b> (12 bit LSB).</p>                        |
| Notes:            | <ul style="list-style-type: none"> <li>To return the current analog offset value, use the command <a href="#">gcp</a> or <a href="#">get sao</a>.</li> </ul>  |
| Example:          | <code>sao 2 35</code>   |
| Related Commands: | <a href="#">cao</a>   |

### Calibrating Analog Offset

|                   |   |
|-------------------|---|
| Purpose:          | Instead of manually setting the analog offset to a specific value, the camera can determine appropriate offset values. This command calculates and averages each tap's pixels within the region of interest and sets the offset to achieve the specified average target value.  |
| Syntax:           | <code>cao t i</code>  |
| Syntax Elements:  | <p><code>t</code></p> <p>Tap selection. Use <b>0</b> for all taps or <b>1 to 2</b> for individual tap selection if you are using the two tap model.</p> <p><code>i</code></p> <p>Average target value in a range from <b>1</b> to <b>255DN</b> (12 bit LSB). <b>Note:</b> Due to the sensor dark current, the range of operation of the <code>cao</code> command is temperature and line rate dependent. Lower <code>cao</code> values cannot be achieved when using lower line rates and higher temperatures. The camera sends a warning message when this occurs.</p> |
| Notes:            | <ul style="list-style-type: none"> <li>Perform analog offset calibration before performing FPN and PRNU coefficients.</li> <li>To return the current analog offset values, use the command <a href="#">gcp</a> or <a href="#">get cao</a>.</li> </ul>   |
| Example:          | <code>cao 1 50</code>   |
| Related Commands: | <a href="#">sao</a>   |

### To update the analog gain reference:

|          |  |
|----------|--|
| Purpose: | Sets the current analog gain setting to be the 0dB point. This is useful after tap gain matching allowing you to change the gain on all taps by the same amount. |
| Syntax:  | <code>ugr</code>   |

## Calibrating the Camera to Remove Non-Uniformity (Flat Field Correction)

### *Flat Field Correction Overview*

**Note: The QuickCam software that ships with the Spyder 3 GigE camera has a flat field correction wizard. For easy flat field correction, use the wizard located on the Calibration tab.**

This camera has the ability to calculate correction coefficients in order to remove non-uniformity in the image. This video correction operates on a pixel-by-pixel basis and implements a two point correction for each pixel. This correction can reduce or eliminate image distortion caused by the following factors:

- Fixed Pattern Noise (FPN)
- Photo Response Non Uniformity (PRNU)
- Lens and light source non-uniformity

Correction is implemented such that for each pixel:

$$V_{\text{output}} = [(V_{\text{input}} - \text{FPN}(\text{pixel}) - \text{digital offset}) * \text{PRNU}(\text{pixel}) - \text{Background Subtract}] \times \text{System Gain}$$

|       |                             |   |  |
|-------|-----------------------------|---|--|
| where | $V_{\text{output}}$         | = | digital output pixel value                 |
|       | $V_{\text{input}}$          | = | digital input pixel value from the CCD     |
|       | $\text{PRNU}(\text{pixel})$ | = | PRNU correction coefficient for this pixel |
|       | $\text{FPN}(\text{pixel})$  | = | FPN correction coefficient for this pixel  |
|       | Background Subtract         | = | background subtract value                  |
|       | System Gain                 | = | digital gain value                         |

The algorithm is performed in two steps. The fixed offset (FPN) is determined first by performing a calibration without any light. This calibration determines exactly how much offset to subtract per pixel in order to obtain flat output when the CCD is not exposed.

The white light calibration is performed next to determine the multiplication factors required to bring each pixel to the required value (target) for flat, white output. Video output is set slightly above the brightest pixel (depending on offset subtracted).

### *Flat Field Correction Restrictions*

It is important to do the FPN correction first. Results of the FPN correction are used in the PRNU procedure. We recommend that you repeat the correction when a temperature change greater than 10°C occurs or if you change the analog gain, integration time, or line rate.

PRNU correction requires a clean, white reference. The quality of this reference is important for proper calibration. White paper is often not sufficient because the grain in the white paper will distort the correction. White plastic or white ceramic will lead to better balancing.

**Note:** If your illumination or white reference does not extend the full field of view of the camera, the camera will send a warning.

For best results, ensure that:

- 50 or 60 Hz ambient light flicker is sufficiently low not to affect camera performance and calibration results.
- For best results, the analog gain should be adjusted for the expected operating conditions and the ratio of the brightest to darkest pixel in a tap should be less than 3 to 1 where:

$$3 > \frac{\text{Brightest Pixel (per tap)}}{\text{Darkest Pixel (per tap)}}$$

- The camera is capable of operating under a range of 8 to 1, but will clip values larger than this ratio.
- The brightest pixel should be slightly below the target output.
- When 6.25% of pixels from a single row within the region of interest are clipped, flat field correction results may be inaccurate.
- Correction results are valid only for the current analog gain and offset values. If you change these values, it is recommended that you recalculate your coefficients.

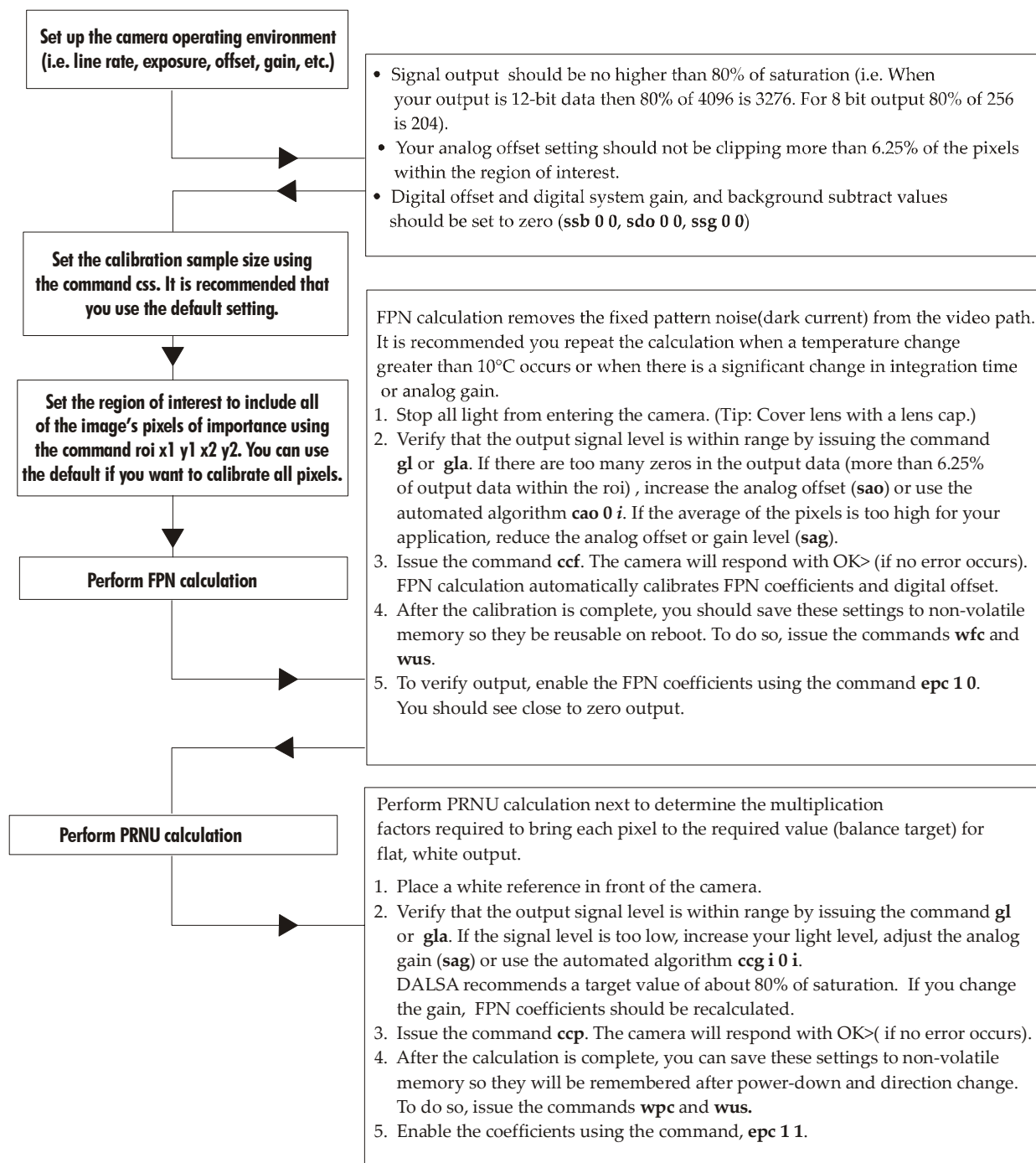

**Note: All commands listed above are described in detail in the following sections in the order that they should be performed.**

## Digital Signal Processing

To optimize camera performance, digital signal processing should be completed after any analog adjustments.

### *FPN Correction*

#### Performing FPN Correction

|                   |  |
|-------------------|--|
| Syntax:           | Performs FPN correction and eliminates FPN noise by subtracting away individual pixel dark current.  |
| Syntax:           | <b>ccf</b>   |
| Notes:            | <ul style="list-style-type: none"> <li>• Perform all analog and digital adjustments before performing FPN correction.</li> <li>• Perform FPN correction before PRNU correction.</li> <li>• Refer to <a href="#">Calibrating the Camera to Remove Non-Uniformity (Flat Field Correction)</a> on page 70 for a procedural overview on performing flat field correction.</li> <li>• To save FPN coefficients after calibration, use the <a href="#">wfc</a> command. Refer to section A3.1 Saving and Restoring PRNU and FPN Coefficients for details.</li> <li>• The QuickCam software that ships with the Spyder 3 GigE camera has a flat field correction wizard. For easy flat field correction, use the wizard located on the Calibration tab.</li> <li>•</li> </ul> |
| Related Commands: | <a href="#">ccp</a> , <a href="#">wfc</a>  |
| Example:          | <b>ccf</b>   |

#### Setting a Pixel's FPN Coefficient

|                  |   |
|------------------|---|
| Purpose:         | Sets an individual pixel's FPN coefficient.   |
| Syntax           | <b>sfc x i</b>  |
| Syntax Elements: | <p><b>x</b></p> <p>The pixel number from 1 to <b>sensor pixel count</b>.</p> <p><b>i</b></p> <p>Coefficient value in a range from 0 to 2047 (12 bit LSB).</p> |
| Example:         | <b>sfc 10 50</b>  |

### Setting Digital Offset

|                   |  |
|-------------------|--|
| Purpose:          | Sets the digital offset. Digital offset is set to zero when you perform FPN correction ( <a href="#">ccf</a> command). If you are unable to perform FPN correction, you can partially remove FPN by adjusting the digital offset.  |
| Syntax:           | <b>sdo t i</b>   |
| Syntax Elements:  | <p><b>t</b></p> <p>Tap selection. Allowable range is <b>1</b> to <b>2</b> depending on camera model, or <b>0</b> for all taps.</p> <p><b>i</b></p> <p>Subtracted offset value in a range from <b>0</b> to <b>2048</b> where FPN Coefficient= <math>i</math> (12 bit LSB Justified)</p>                     |
| Notes:            | <ul style="list-style-type: none"> <li>When subtracting a digital value from the digital video signal, the output can no longer reach its maximum unless you apply digital gain using the <a href="#">ssg</a> command. See the previous section for details on the <a href="#">ssg</a> command.</li> </ul> |
| Related Commands: | <a href="#">ssg</a>  |
| Example:          | <b>sdo 0 100</b>   |

### PRNU Correction

### Performing PRNU to a user entered value

**Purpose:** Performs PRNU calibration to user entered value and eliminates the difference in responsivity between the most and least sensitive pixel creating a uniform response to light. Using this command, you must provide a calibration target.

Executing these algorithms causes the **ssb** command to be set to 0 (no background subtraction) and the **ssg** command to 4096 (unity digital gain). The pixel coefficients are disabled (**epc 0 0**) during the algorithm execution but returned to the state they were prior to command execution.

**Syntax:** `cpa i i`

**Syntax Elements:** `i`

PRNU calibration algorithm to use:

**1** = This algorithm first adjusts each tap's analog gain so that 8-13% of pixels within a tap are above the value specified in the target value parameter. PRNU calibration then occurs using the peak pixel in the region of interest.

This algorithm is recommended for use only when FPN is negligible and FPN coefficients are set to zero. Since this algorithm adjusts the analog gain, it also affects FPN. If FPN is calibrated prior to running this algorithm, FPN will be observable in dark conditions and an incorrect FPN value will be used during PRNU calibration resulting in incorrect PRNU coefficients.

**2** = Calculates the PRNU coefficients using the entered target value as shown below:

$$\text{PRNU Coefficient}_i = \frac{\text{Target}}{(\text{AVG Pixel Value}_i) - (\text{FPN}_i + \text{sdo value})}$$

The calculation is performed for all sensor pixels but warnings are only applied to pixels in the region of interest. This algorithm is useful for achieving uniform output across multiple cameras. Is is important that the target value (set with the next parameter) is set to be at least equal to the highest pixel across all cameras so that all pixels can reach the highest pixel value during calibration.

**3** = This algorithm includes an analog gain adjustment prior to PRNU calibration. Analog gain is first adjusted so that the peak pixel value in tap's ROI is within 97 to 99% of the specified target value. It then calculates the PRNU coefficients using the target value as shown below:

$$\text{PRNU Coefficient}_i = \frac{\text{Target}}{(\text{AVG Pixel Value}_i) - (\text{FPN}_i + \text{sdo value})}$$

The calculation is performed for all sensor pixels but warnings are only applied to pixels in the region of interest. This algorithm is useful for achieving uniform output across multiple cameras.

This algorithm is useful for achieving uniform output across multiple cameras by first adjusting analog gain and then performing PRNU calibration. This algorithm is recommended for use only when FPN is negligible and FPN coefficients are set to zero. Since this algorithm adjusts the analog gain, it also affects FPN. If FPN is calibrated prior to running this algorithm,

FPN will be observable in dark conditions and an incorrect FPN value will be used during PRNU calibration resulting in incorrect PRNU coefficients.

This algorithm is more robust and repeatable than algorithm 1 because it uses an average pixel value rather than a number above target. However, this algorithm is slower.

#### *i*

Peak target value in a range from 1024 to 4055DN. The target value must be greater than the current peak output value.

#### Notes:

- Perform all analog adjustments before calibrating PRNU.
- This command performs the same function as the `cpp` command but forces you to enter a target value.
- Calibrate FPN before calibrating PRNU. If you are not performing FPN calibration then issue the `rpc` (reset pixel coefficients) command and set the `sdo` (set digital offset) value so that the output is near zero under dark.
- The QuickCam software that ships with the Spyder 3 GigE camera has a flat field correction wizard. For easy flat field correction, use the wizard located on the Calibration tab.

#### Example:

```
cpa 1 600
```

### Performing PRNU Correction to a Camera Calculated Value

#### Purpose:

Performs PRNU correction and eliminates the difference in responsivity between the most and least sensitive pixel creating a uniform response to light.

#### Syntax

```
ccp
```

#### Notes:

- Perform all analog adjustments before calculating PRNU.
- Perform FPN correction before PRNU correction.
- If FPN cannot be calibrated, use the [rpc](#) command to reset all coefficients to zero, and save them to memory with the [wfc](#) command. You can then adjust the digital offset ([sdo](#) command) to remove some of the FPN.
- Ensure camera is operating at its expected analog gain, integration time, and temperature.
- Refer to Calibrating the Camera to Remove Non-Uniformity (Flat Field Correction) on page 70 for a procedural overview on performing flat field correction.
- To save FPN coefficients after calibration, use the [wpc](#) command. Refer to section A3.1 Saving and Restoring PRNU and FPN Coefficients for details.
- The QuickCam software that ships with the Spyder 3 GigE camera has a flat field correction wizard. For easy flat field correction, use the wizard located on the Calibration tab.

#### Related Commands:

[ccf](#), [cpa](#)

**cpa i i**

*i*

- Perform all analog adjustments before calibrating PRNU.
- This command performs the same function as the **cpp** command but forces you to enter a target value.
- Calibrate FPN before calibrating PRNU. If you are not performing FPN calibration then issue the **rpc** (reset pixel coefficients) command and set the **sdo** (set digital offset) value so that the output is near zero under dark.
- Note: Refer to Calibrating the Camera to Remove Non-Uniformity (Flat Field Correction) on page 70 for a procedural overview on performing flat field correction.

**cpa 1 600**

### Setting a Pixel's PRNU Coefficient

Purpose: Sets an individual pixel's PRNU coefficient.

Syntax: **spc i i**

Syntax Elements: *i*

The pixel number from 1 to **sensor pixel count**.

*i*

Coefficient value in a range from 0 to 28671 where:

$$\text{PRNU coefficient} = 1 + \frac{i}{4096}$$

Example: **spc 1024 10000**

### Subtracting Background

Purpose: Use the background subtract command after performing flat field correction if you want to improve your image in a low contrast scene. It is useful for systems that process 8 bit data but want to take advantage of the camera's 12 bit digital processing chain. You should try to make your darkest pixel in the scene equal to zero.

Syntax: **ssb t i**

Syntax Elements: **t**

Tap selection. Allowable range is 1 to 2 depending on camera model, or 0 for all taps.

*i*

Subtracted value in a range in DN from 0 to 4095.

- Notes:
- When subtracting a digital value from the digital video signal the output can no longer reach its maximum. Use the [ssg](#) command to correct for this where:

$$\text{ssg value} = \frac{\text{max output value}}{\text{max output value} - \text{ssb value}}$$

See the following section for details on the [ssg](#) command.

Related Commands: [ssg](#)

Example **ssb 0 25**

### Setting Digital System Gain

Purpose: Improves signal output swing after a background subtract. When subtracting a digital value from the digital video signal, using the [ssb](#) command, the output can no longer reach its maximum. Use this command to correct for this where:

$$\text{ssg value} = \frac{\text{max output value}}{\text{max output value} - \text{ssb value}}$$

Syntax: **ssg t i**

Syntax Elements: **t**

Tap selection. Allowable range is **1 to 2**, or **0** for all taps.

**i**

Gain setting. The gain ranges are **0 to 65535**. The digital video values are multiplied by this value where:

$$\text{Digital Gain} = \frac{i}{4096}$$

Use this command in conjunction with the [ssb](#) command.

Related Commands: [ssb](#)

Example: **ssg 1 15**

## Returning Calibration Results and Errors

### Returning All Pixel Coefficients

|                  |   |
|------------------|---|
| Purpose:         | Returns all the current pixel coefficients in the order FPN, PRNU, FPN, PRNU... for the range specified by <b>x1</b> and <b>x2</b> . The camera also returns the pixel number with every fifth coefficient.     |
| Syntax:          | <b>dpc x1 x2</b>  |
| Syntax Elements: | <b>x1</b><br><br>Start pixel to display in a range from 1 to <b>sensor pixel count</b> .<br><br><b>x2</b><br><br>End pixel to display in a range from <b>x1</b> to <b>sensor pixel count</b> .                  |
| Notes:           | <ul style="list-style-type: none"> <li>This function returns all the current pixel coefficients in the order FPN, PRNU, FPN, PRNU... The camera also returns the pixel number with each coefficient.</li> </ul> |
| Example:         | <b>dpc 10 20</b>  |

### Returning FPN Coefficients

|                  |   |
|------------------|---|
| Purpose:         | Returns a pixel's FPN coefficient value in DN (12 bit LSB)                                |
| Syntax:          | <b>gfc i</b>  |
| Syntax Elements: | <b>i</b><br><br>The pixel number to read in a range from 1 to <b>sensor pixel count</b> . |
| Example:         | <b>gfc 10</b>   |

### Returning PRNU Coefficients

|                  |   |
|------------------|---|
| Purpose:         | Returns a pixel's PRNU coefficient value in DN (12 bit LSB)                               |
| Syntax:          | <b>gpc i</b>  |
| Syntax Elements: | <b>i</b><br><br>The pixel number to read in a range from 1 to <b>sensor pixel count</b> . |
| Example:         | <b>gpc 10</b>   |

### *Enabling and Disabling Pixel Coefficients*

Purpose: Enables and disables FPN and PRNU coefficients.

Syntax: `epc i i`

Syntax Elements: `i`

FPN coefficients.  
`0` = FPN coefficients disabled  
`1` = FPN coefficients enabled

`i`

PRNU coefficients.  
`0` = PRNU coefficients disabled  
`1` = PRNU coefficients enabled

Example: `epc 0 1`

## A2.3 End-of-line Sequence

Purpose: Produces an end-of-line sequence that provides basic calculations including "line counter", "line sum", "pixels above threshold", "pixels below threshold", and "derivative line sum" within the region of interest. These basic calculations are used to calibrate analog offset ([cao](#)) and calibrate analog gain ([ccg](#)). To further aid in debugging and cable/data path integrity, the first three pixels after Line Valid are "aa", "55", "aa". Refer to the following table. These statistics refer only to pixels within the region of interest.

Syntax: `els i`

Syntax Elements: `i`

`0` Disable end-of-line sequence  
`1` Enable end-of-line sequence

Notes:

- LVAL is not high during the end-of-line statistics.

Example: `els 1`

**Table 12: End-of-Line Sequence Description**

| Location | Value                       | Description   |
|----------|-----------------------------|---|
| 1        | A's                         | By ensuring these values consistently toggle between "aa" and "55", you can verify cabling (i.e. no stuck bits) |
| 2        | 5's                         |   |
| 3        | A's                         |   |
| 4        | 4 bit counter LSB justified | Counter increments by 1. Use this value to verify that every line is output                                     |
| 5        | Line sum (7...0)            | Use these values to help calculate line average and gain  |
| 6        | Line sum (15...8)           |   |
| 7        | Line sum (23...16)          |   |
| 8        | Line sum (31...24)          |   |

| Location | Value                           | Description  |
|----------|---------------------------------|--|
| 9        | Pixels above threshold (7...0)  | Monitor these values (either above or below threshold) and adjust camera digital gain and background subtract to maximize scene contrast. This provides a basis for automatic gain control (AGC) |
| 10       | Pixels above threshold (15...8) |  |
| 11       | Pixels below threshold (7...0)  |  |
| 12       | Pixels below threshold (15...8) |  |
| 13       | Differential line sum (7..0)    | Use these values to focus the camera. Generally, the greater the sum the greater the image contrast and better the focus.  |
| 14       | Differential line sum (15...8)  |  |
| 15       | Differential line sum (23...16) |  |
| 16       | Differential line sum (31...24) |  |

## Setting Thresholds

### Setting an Upper Threshold

|                   |   |
|-------------------|---|
| Purpose:          | Sets the upper threshold limit to report in the end-of-line sequence.                                 |
| Syntax:           | <b>sut i</b>  |
| Syntax Elements:  | <b>i</b><br>Upper threshold limit in range from 0 to 4095.  |
| Notes:            | <ul style="list-style-type: none"> <li>LVAL is not high during the end-of-line statistics.</li> </ul> |
| Related Commands: | <ul style="list-style-type: none"> <li><a href="#">els</a>, <a href="#">slt</a></li> </ul>            |
| Example:          | <b>sut 1024</b>   |

### Setting a Lower Threshold

|                   |   |
|-------------------|---|
| Purpose:          | Sets the lower threshold limit to report in the end-of-line sequence.                                 |
| Syntax:           | <b>slt i</b>  |
| Syntax Elements:  | <b>i</b><br>Upper threshold limit in range from 0 to 4095.  |
| Notes:            | <ul style="list-style-type: none"> <li>LVAL is not high during the end-of-line statistics.</li> </ul> |
| Related Commands: | <ul style="list-style-type: none"> <li><a href="#">els</a>, <a href="#">sut</a></li> </ul>            |
| Example:          | <b>slt 1024</b>   |

## A3 Saving and Restoring Settings

For each camera operating mode (high sensitivity forward direction, high sensitivity reverse direction, low sensitivity, or tall pixel), the camera has distinct factory settings, current settings, and user settings. In addition, there is one set of factory pre-calibrated pixel coefficients and up to four sets of user created pixel coefficients for each operating mode.

**Figure 25: Saving and Restoring Overview**

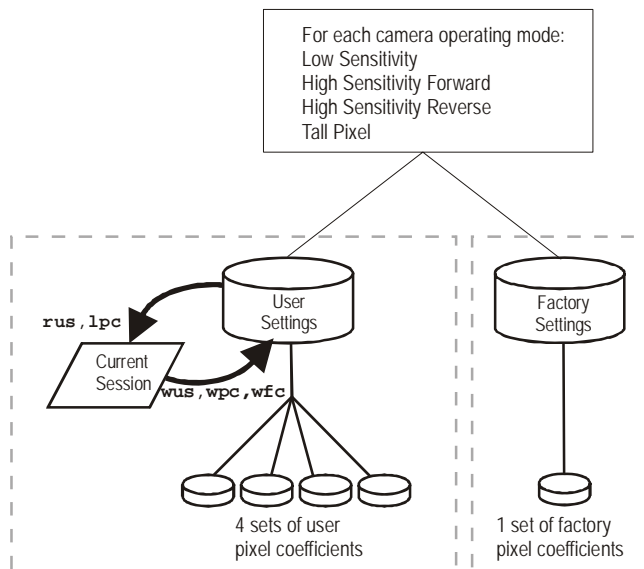

### Factory Settings

On first initialization, the camera operates using the factory settings. You can restore the original factory settings at any time using the command **rfs**.

### User Settings

You can save or restore your user settings to non-volatile memory using the following commands. Pixel coefficients are stored separately from other data.

- To save all current user settings to EEPROM, use the command **wus**. The camera will automatically restore the saved user settings when powered up. **Note:** While settings are being written to nonvolatile memory, do not power down camera or camera memory may be corrupted.
- To restore the last saved user settings, use the command **rus**.
- To save the current pixel coefficients, use the command **wpc** and **wfc**.
- To restore the last saved pixel coefficients, use the command **lpc**.

### Current Session Settings

These are the current operating settings of your camera. To save these settings to non-volatile memory, use the command **wus**.

## A3.1 Saving and Restoring PRNU and FPN Coefficients

### Saving the Current PRNU Coefficients

**Purpose:** Saves the current PRNU coefficients. You can save up to four sets of pixel coefficients

**Syntax:** `wpc i`

**Syntax Elements:** `i`

PRNU coefficients set to save.

**1** = Coefficient set one

**2** = Coefficient set two

**3** = Coefficient set three

**4** = Coefficient set four

**Example:** `wpc 2`

### Saving the Current FPN Coefficients

**Purpose:** Saves the current FPN coefficients. You can save up to four sets of pixel coefficients

**Syntax:** `wfc i`

**Syntax Elements:** `i`

FPN coefficients set to save.

**1** = Coefficient set one

**2** = Coefficient set two

**3** = Coefficient set three

**4** = Coefficient set four

**Example:** `wfc 2`

### Loading a Saved Set of Coefficients

**Purpose:** Loads a saved set of pixel coefficients. A factory calibrated set of coefficients is available.

**Syntax:** `lpc i`

**Syntax Elements:** `i`

FPN coefficients set to save.

**0** = Factory calibrated pixel coefficients.

**1** = Coefficient set one

**2** = Coefficient set two

**3** = Coefficient set three

**4** = Coefficient set four

**Example:** `lpc 0`

### Resetting the Current Pixel Coefficients

**Purpose:** Resets the current pixel coefficients to zero. This command does not reset saved coefficients.

**Syntax:** `rpc`

**Notes:** The digital offset is not reset.

## A3.2 Rebooting the Camera

The command `rc` reboots the camera. The camera starts up with the last saved settings and the baud rate used before reboot. Previously saved pixel coefficients are also restored.

# A4 Diagnostics

## A4.1 Generating a Test Pattern

**Purpose:** Generates a test pattern to aid in system debugging. The test patterns are useful for verifying camera timing and connections. The following tables show each available test pattern.

**Syntax:** `svm i`

**Syntax Elements:** `i`

0 Video.

1 12 bit ramp test pattern.



2 tap model



1 tap model

2 8 bit step test pattern.



2 tap model



1 tap model

Example: `svm 1`

### A4.1.1 Ethernet Test Pattern

A third test pattern – Ethernet – is accessible using the QuickCam GUI.

**Purpose:** Generates a test pattern to aid in system debugging. The test patterns are useful for verifying camera timing and connections. The following table shows the ethernet test pattern available through the QuickCam GUI.

**Availability:** Under the Diagnostics tab in the Test Patter drop-down list. Ethernet.



2 tap model

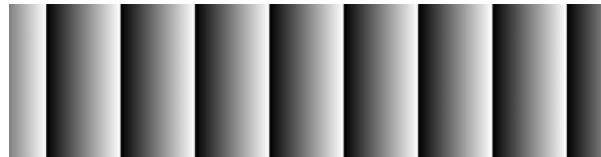

1 tap model

## A4.2 Returning Video Information

The camera's microcontroller has the ability to read video data. This functionality can be used to verify camera operation and to perform basic testing without having to connect the camera to a frame grabber. This information is also used for collecting line statistics for calibrating the camera.

### Returning a Single Line of Video

|                  |  |
|------------------|--|
| Purpose:         | Returns a complete line of video (without pixel coefficients applied) displaying one pixel value after another. After pixel values have been displayed it also displays the minimum, maximum, and mean value of the line sampled within the region of interest (the region of interest command is explained in section A2.1 Setting a Region of Interest (ROI)).<br>Use the <b>g1</b> command, or the following <a href="#">g1a</a> command, to ensure the proper video input range into the processing chain before executing any pixel calibration commands. |
| Syntax:          | <b>g1 x1 x2</b>  |
| Syntax Elements: | <b>x1</b><br>Pixel start number. Must be less than the pixel end number in a range from <b>1</b> to <b>sensor resolution</b> .<br><b>x2</b><br>Pixel end number. Must be greater than the pixel start number in a range from <b>2</b> to <b>sensor resolution</b> .  |
| Notes:           | <ul style="list-style-type: none"> <li>• If <math>x2 \leq x1</math> then <b>x2</b> is forced to be <b>x1</b>.</li> <li>• Values returned are in 12-bit DN.</li> </ul>  |
| Related Commands | <a href="#">roi</a>  |
| Example:         | <b>g1 10 20</b>  |

### Returning Averaged Lines of Video

#### Setting the Number of Lines to Sample

|                   |   |
|-------------------|---|
| Purpose:          | Sets the number of lines to sample when using the <b>g1a</b> command or when performing FPN and PRNU calibration.                                 |
| Syntax:           | <b>css m</b>  |
| Syntax Elements:  | <b>m</b><br>Number of lines to sample. Allowable values are <b>256</b> , <b>512</b> , or <b>1024</b> (factory setting).                           |
| Notes:            | <ul style="list-style-type: none"> <li>• To return the current setting, use the <a href="#">gcp</a> command or <a href="#">getcss</a>.</li> </ul> |
| Related Commands: | <a href="#">g1a</a> , <a href="#">ccf</a> , <a href="#">ccp</a> , <a href="#">cpa</a>   |
| Example:          | <b>css 1024</b>   |

### Returning the Average of Multiple Lines of Video

|                   |  |
|-------------------|--|
| Purpose:          | Returns the average for multiple lines of video data (without pixel coefficients applied). The number of lines to sample is set and adjusted by the <b>css</b> command. The camera displays the Min., Max., and Mean statistics for the pixels in the region of interest (the region of interest command is explained in section A2.1 Setting a Region of Interest (ROI)). |
| Syntax:           | <b>gla x1 x2</b>   |
| Syntax Elements:  | <b>x1</b><br>Pixel start number. Must be less than the column end number in a range from <b>1</b> to sensor <b>resolution</b> .<br><b>x2</b><br>Pixel end number. Must be greater than the column start number in a range from <b>2</b> to column resolution.  |
| Notes:            | <ul style="list-style-type: none"> <li>• If <math>x2 \leq x1</math> then <b>x2</b> is forced to be <b>x1</b>.</li> <li>• Analog gain, analog offset, digital offset, background subtract, and digital system gain are applied to the data. FPN and PRNU coefficients are not included in the data.</li> <li>• Values returned are in 12 bit DN.</li> </ul>                 |
| Related Commands: | <a href="#">css</a> , <a href="#">roi</a>  |
| Example:          | <b>gla 10 20</b>   |

## A4.3 Temperature Measurement

The temperature of the camera can be determined by using the **vt** command. This command will return the internal chip case temperature in degrees Celsius. For proper operation, this value should not exceed 75°C.

**Note:** If the camera reaches 75°C, the camera will shutdown and the LED will flash red. If this occurs, the camera must be rebooted using the command, **rc** or can be powered down manually. You will not be able to restart the camera until the temperature is less than 65°C. You will have to correct the temperature problem or the camera will shutdown again. The camera allows you to send the **vt** (verify temperature) command while it is in this state.

## A4.4 Voltage Measurement

The command **vv** displays the camera's input voltage. Note that the voltage measurement feature of the camera provides only approximate results (typically within 10%). The measurement should not be used to set the applied voltage to the camera but only used as a test to isolate gross problems with the supply voltage.

## A4.5 Camera Frequency Measurement

|                  |  |
|------------------|--|
| Purpose:         | Returns the frequency for the requested Camera Link control signal   |
| Syntax:          | <b>gsf i</b>   |
| Syntax Elements: | <b>i</b>   |
|                  | Camera Link control signal to measure:<br><b>1:</b> CC1 (EXSYNC)<br><b>2:</b> CC2 (PRIN)<br><b>3:</b> CC3 (CCD Direction)<br><b>4:</b> CC4 (Spare)   |
| Note:            | <ul style="list-style-type: none"> <li>• Camera operation may be impacted when entering the gsf command (i.e., poor time response to direction change or video may have artifacts (gain changes) for several lines while the camera returns signal information)</li> <li>• This command is not available when operating the camera with external CCD direction control (<b>scd 2</b>)</li> </ul> |
| Example:         | <b>gsf 1</b>   |

## A4.6 Returning the LED Status

|          |   |
|----------|---|
| Purpose: | Returns the status of the camera's LED.   |
| Syntax:  | <b>gs1</b>  |
|          | The camera returns one of the following values:<br><b>1</b> = red (loss of functionality)<br><b>2</b> = green (camera is operating correctly)<br><b>5</b> = flashing green (camera is performing a function)<br><b>6</b> = flashing red (fatal error) |
| Notes:   | <ul style="list-style-type: none"> <li>• Refer to section 2.5 Camera LED for more information on the camera LED</li> </ul>  |

## A4.7 Returning Camera Settings

### Returning All Camera Settings with the Camera Parameter Screen

The camera parameter (gcp) screen returns all of the camera's current settings. The table below lists all of the gcp screen settings.

**To read all current camera settings, use the command:**

Syntax: `gcp`

| GCP Screen              |                  | Description  |
|-------------------------|------------------|--|
| GENERAL CAMERA SETTINGS |                  |  |
| Camera Model No.:       | SG-10-02K80      | Camera model number.   |
| Camera Serial No.:      | XXXXXXXXXX       | Camera serial number.  |
| Firmware Version:       | XX-XX-XXXXX-XX   | Firmware design revision number.   |
| CCI Version:            | XX-XXX-XXXXX-XX  | CCI version number.  |
| FPGA Version:           | XXX.XX           | FPGA revision number.  |
| UART Baud Rate:         | 115200           | Serial communication connection speed set with the <a href="#">sbr</a> command. See Setting Baud Rate on page 54 for details.                                |
| Dual Scan Mode:         | High Sensitivity | Current sensitivity mode set with the <a href="#">shm</a> command. See section A1.1 Sensitivity Mode for details.  |
| Camera Mode:            | 2 taps, 12 bits  | Current bit depth setting set with the <a href="#">sdm</a> command. Refer to section A1.3 Setting the Bit Depth for details.                                 |
| Readout Mode:           | Off              | Current readout mode status. Set using the <a href="#">srm</a> command.  |
| Exposure Mode:          | 7                | Current exposure mode value set with the <a href="#">sem</a> command. See section A1.4 Exposure Mode, Readout Mode, Line Rate and Exposure Time for details. |
| SYNC Frequency:         | 5000.00 Hz       | Current line rate. Value is set with the <a href="#">ssf</a> command. See section A1.4 Exposure Mode, Readout Mode, Line Rate and Exposure Time for details. |

|                              |                           |  |
|------------------------------|---------------------------|--|
| <b>Exposure Time:</b>        | <b>200.00 uSec</b>        | Current exposure time setting. Value is set with the <a href="#">set</a> command. See section A1.4 Exposure Mode, Readout Mode, Line Rate and Exposure Time for details. |
| <b>CCD Direction:</b>        | <b>internal/forward</b>   | Current direction setting set with <code>scd</code> command. Refer to section A1.2 CCD Shift Direction for details.  |
| <b>Horizontal Binning:</b>   | <b>1</b>                  | Current horizontal binning factor set with the <code>sbh</code> command.   |
| <b>Video Mode:</b>           | <b>video</b>              | Current video mode value set with the <a href="#">svm</a> command. See section A4.1 Generating a Test Pattern for details.   |
| <b>Region of Interest:</b>   | <b>(1,1) to (2048, 1)</b> | Region of interest size set with the <a href="#">roi</a> command. See section A2.1 Setting a Region of Interest (ROI) for details.                                       |
| <b>End-Of-Line Sequence:</b> | <b>on</b>                 | States whether an end of line sequence is turned on or off. Set using the <a href="#">els</a> command. See section A2.3 End-of-line Sequence for details.                |
| <b>FFC Coefficient Set:</b>  | <b>0</b>                  | Current pixel coefficient set loaded. Refer to section A3.1 Saving and Restoring PRNU and FPN Coefficients for details.  |
| <b>FPN Coefficients:</b>     | <b>off</b>                | States whether FPN coefficients are on or off. Set with the <a href="#">epc</a> command. Refer to section A2.2 Analog and Digital Signal Processing Chain for details.   |
| <b>PRNU Coefficients:</b>    | <b>off</b>                | States whether PRNU coefficients are on or off. Set with the <a href="#">epc</a> command. Refer to section A2.2 Analog and Digital Signal Processing Chain for details.  |

|                                   |                |   |
|-----------------------------------|----------------|---|
| <b>Number of Line Samples:</b>    | <b>1024</b>    | Number of lines samples set with the <a href="#">css</a> command. See section A4.2 Returning Video Information for details.                     |
| <b>Upper Threshold</b>            | <b>3600</b>    | Upper threshold value set with the <a href="#">sut</a> command.<br>See section A2.3 End-of-line Sequence for details.                           |
| <b>Lower Threshold</b>            | <b>400</b>     | Lower threshold value set with the <a href="#">slt</a> command. See section A2.3 End-of-line Sequence for details.                              |
| <b>Analog Gain (dB):</b>          | <b>0.0 0.0</b> | Analog gain settings set with the <a href="#">sag</a> command. See section A2.2 Analog and Digital Signal Processing Chain for details.         |
| <b>Analog Gain Reference(dB):</b> | <b>0.0 0.0</b> | Analog reference gain set with the <a href="#">ugr</a> command.<br>See section A2.2 Analog and Digital Signal Processing Chain for details.     |
| <b>Total Analog Gain (dB):</b>    | <b>0.0 0.0</b> | This is the sum of the analog gain and analog gain reference values and is the total analog gain being used by the camera.                      |
| <b>Analog Offset:</b>             | <b>70 70</b>   | Analog offset settings set with the <a href="#">sao</a> command. See section A2.2 Analog and Digital Signal Processing Chain for details.       |
| <b>Digital Offset:</b>            | <b>0 0</b>     | Digital offset settings set with the <a href="#">sdo</a> command. See section A2.2 Analog and Digital Signal Processing Chain for details.      |
| <b>Background Subtract:</b>       | <b>0 0</b>     | Background subtract settings set with the <a href="#">ssb</a> command. See section A2.2 Analog and Digital Signal Processing Chain for details. |

|                    |   |  |
|--------------------|---|--|
| System Gain (DN):  | 4096 4096   | Digital gain settings set with the <a href="#">ssg</a> command. See section A2.2 Analog and Digital Signal Processing Chain for details. |
| GPIO Configuration | <pre> Signal  Mode Input0  Disabled Input1  Disabled Input2  Disabled Input3  Disabled Output0 High Impedance Output1 High Impedance Output2 High Impedance Output3 High Impedance </pre> | Current GPIO pinout configuration. Refer to section A1.5 Configuring the GPIO Connector for details.                                     |

## Returning Camera Settings with Get Commands

You can also return individual camera settings by inserting a “**get**” in front of the command that you want to query. If the command has a tap or pixel number parameter, you must also insert the tap number or pixel number that you want to query. Refer to Table 13 below for a list of available commands. To view a help screen listing the following get commands, use the command **gh**.

**Table 13: Get Commands**

| Syntax         | Parameters   | Description   |
|----------------|--------------|---|
| <b>get cao</b> | <b>t</b>     | Returns the analog offset for the tap indicated<br><b>t</b> = tap selection, either 1 to 2 depending on camera model, or 0 for all taps |
| <b>get ccf</b> | <b>x1 x2</b> | Returns the FPN pixel coefficients for the pixel range indicated.<br><b>x1</b> = Pixel start number<br><b>x2</b> = Pixel end number     |
| <b>get ccp</b> | <b>x1 x2</b> | Returns the PRNU pixel coefficients for the pixel range indicated.<br><b>x1</b> = Pixel start number<br><b>x2</b> = Pixel end number    |
| <b>get css</b> |              | Returns the number of line samples averaged for pixel coefficient calculations or for output of <b>gla</b> command.                     |
| <b>get dgc</b> |              | Returns the current GPIO configuration.   |
| <b>get dpc</b> | <b>x1 x2</b> | Returns pixel coefficients without formatting.  |
| <b>get els</b> |              | Returns whether the end-of-line statistics are turned off or on.<br>0: Off<br>1: On   |

| Syntax               | Parameters         | Description   |
|----------------------|--------------------|---|
| <code>get epc</code> |                    | Returns whether pixel coefficients are enabled or disabled.<br>The first parameter returns the FPN coefficients setting where:<br>0 = FPN coefficients disabled<br>1 = FPN coefficients enabled<br>The second parameter returns the PRNU coefficients setting where:<br>0 = PRNU coefficients disabled<br>1 = PRNU coefficients enabled |
| <code>get gcm</code> |                    | Returns the camera's model number   |
| <code>get gcs</code> |                    | Returns the camera's serial number  |
| <code>get gcv</code> |                    | Returns the camera's software version.  |
| <code>get ger</code> |                    | Returns the maximum exposure time for the current line rate.  |
| <code>get gfc</code> | <code>x</code>     | Returns the FPN pixel coefficient for the pixel indicated.  |
| <code>get gl</code>  | <code>x1 x2</code> | Returns pixel values for the pixel range specified.   |
| <code>get gla</code> | <code>x1 x2</code> | Returns the average of the pixel range indicated.   |
| <code>get gpc</code> | <code>x</code>     | Returns the PRNU pixel coefficient for the pixel indicated.   |
| <code>get gsf</code> | <code>i</code>     | Returns the frequency of the Camera Link control signal indicated, either <b>1</b> , <b>2</b> , <b>3</b> , or <b>4</b> .  |
| <code>get gsl</code> |                    | Returns the led status where:   |
| <code>get lpc</code> |                    | Returns the current coefficient set number.   |
| <code>get rfs</code> |                    | Returns whether factory settings have been saved. The camera always returns <b>1</b> (factory settings have been saved).  |
| <code>get roi</code> |                    | Returns the current region of interest.   |
| <code>get rus</code> |                    | Returns whether user settings have been saved.<br>0 = No user settings saved<br>1 = User settings have been saved   |
| <code>get sag</code> | <code>t</code>     | Returns the analog gain in dB for the tap indicated<br><code>t</code> = Tap value. <b>0</b> for all taps or <b>1</b> to <b>2</b> for individual tap selection.  |
| <code>get sao</code> | <code>t</code>     | Returns the analog offset for the tap indicated.<br><code>t</code> = <b>0</b> for all taps or <b>1</b> to <b>2</b> for individual tap selection.  |
| <code>get sbh</code> |                    | Returns the horizontal binning factor.  |
| <code>get sbr</code> |                    | Returns the speed of camera serial communication port.  |

| Syntax               | Parameters     | Description  |
|----------------------|----------------|--|
| <code>get scd</code> |                | Returns the ccd shift direction where:<br><b>0</b> = Forward CCD shift direction.<br><b>1</b> = Reverse CCD shift direction.<br><b>2</b> = Externally controlled direction control via CC3.  |
| <code>get sdm</code> |                | Returns the current camera configuration where:<br><b>0</b> = 8 bits, 1 tap, 40MHz data rate<br><b>1</b> = 12 bits, 1 tap, 40MHz data rate<br><b>2</b> = 8 bits, 2 taps, 80Mhz data rate<br><b>3</b> = 12 bits, 2 taps, 80MHz data rate  |
| <code>get sdo</code> | <code>t</code> | Returns the digital offset value in DN for the tap indicated.<br><b>t</b> = Tap value. <b>0</b> for all taps or <b>1</b> to <b>2</b> for individual tap selection.   |
| <code>get sem</code> |                | Returns the current exposure mode:<br><b>2</b> = Internal SYNC, internal PRIN, programmable line rate and exposure time using commands <b>ssf</b> and <b>set</b><br><b>3</b> = External SYNC, internal PRIN, maximum exposure time<br><b>4</b> = Smart EXSYNC<br><b>5</b> = External SYNC and PRIN<br><b>6</b> = External SYNC, internal PRIN, programmable exposure time<br><b>7</b> = Internal programmable SYNC, maximum exposure time. Factory setting.<br><b>8</b> = Internal SYNC, internal PRIN, programmable exposure time. Maximum line rate for exposure time. |
| <code>get set</code> |                | Returns the current exposure time in $\mu$ s.  |
| <code>get sfc</code> | <code>x</code> | Returns the FPN coefficient for the pixel number idicated.<br><b>x</b> =pixel number within the range <b>1</b> to <b>sensor pixel count</b> .  |
| <code>get sgi</code> | <code>i</code> | Returns the current input signal setting for the input number specified where:<br><b>0</b> = disabled<br><b>1</b> = TTL<br><b>2</b> = LVDS   |
| <code>get sgo</code> | <code>i</code> | Returns the current output signal setting for the output number specified where:<br><b>0</b> = disabled<br><b>1</b> = TTL<br><b>2</b> = LVDS   |
| <code>get slt</code> |                | Returns the current lower threshold value.   |
| <code>get spc</code> | <code>x</code> | Returns the PRNU coefficient for the specified pixel number.<br><b>x</b> =pixel number within the range <b>1</b> to <b>sensor pixel count</b> .  |

| Syntax               | Parameters     | Description   |
|----------------------|----------------|---|
| <code>get ssb</code> | <code>t</code> | Returns the current background subtract value.<br><code>t</code> = Tap value. <b>0</b> for all taps or <b>1</b> to <b>2</b> for individual tap selection depending on camera model. |
| <code>get ssf</code> |                | Returns the current line/frame rate in Hz.  |
| <code>get ssg</code> | <code>t</code> | Returns the current digital gain setting.<br><code>t</code> = tap selection, either <b>1</b> to <b>2</b> depending on camera model, or <b>0</b> for all taps                        |
| <code>get ssm</code> |                | Returns the current sensitivity mode where:<br><b>0</b> = Low sensitivity mode<br><b>1</b> = High sensitivity mode<br><b>2</b> = Tall pixel mode                                    |
| <code>get sut</code> |                | Returns the current upper threshold value.  |
| <code>get svm</code> |                | Returns the current video mode.<br><b>0</b> : Normal video mode<br><b>1</b> : Test pattern<br><b>2</b> : Test pattern   |
| <code>get ugr</code> | <code>t</code> | Returns the gain reference value.<br><code>t</code> = tap selection, either <b>1</b> to <b>2</b> depending on camera model, or <b>0</b> for all taps                                |
| <code>get vt</code>  |                | Returns the camera's internal chip temperature in degrees Celsius.  |
| <code>get vv</code>  |                | Returns the camera's supply voltage.  |
| <code>get wfc</code> |                | Returns whether FPN coefficients have been saved.<br><b>0</b> = No FPN coefficients saved<br><b>1</b> = Pixel coefficients have been saved  |
| <code>get wpc</code> |                | Returns whether PRNU coefficients have been saved.<br><b>0</b> = No PRNU coefficients saved<br><b>1</b> = Pixel coefficients have been saved  |
| <code>get wus</code> |                | Returns whether user settings have been saved.<br><b>0</b> = No user settings saved<br><b>1</b> = User settings have been saved   |

## ASCII Commands: Reference

The following table lists all of the camera's available ASCII commands. Refer to Appendix A for detailed information on using these ASCII commands.

### Parameters:

**t** = tap id

**i** = integer value

**f** = float

**m** = member of a set

**s** = string

**x** = pixel column number

**y** = pixel row number

**Table 14: Command Quick Reference**

| Mnemonic                  | Syntax     | Parameters   | Description   |
|---------------------------|------------|--------------|---|
| calibrate analog offset   | <b>cao</b> | <b>t i</b>   | Calibrates the analog gain and averages each tap's pixels within the ROI to the specified average target value.<br><b>t</b> = tap selection, either <b>1</b> or <b>2</b> depending on camera model, or <b>0</b> for all taps<br><b>i</b> = target value in a range from <b>1</b> to <b>255DN</b> (12 bit LSB)   |
| correction calibrate fpn  | <b>ccf</b> |              | Performs FPN calibration and eliminates FPN noise by subtracting away individual pixel dark current.  |
| calculate camera gain     | <b>ccg</b> | <b>i t i</b> | Calculates the camera gain according to the selected algorithm.<br><b>i</b> = Calibration algorithm to use.<br><b>1</b> = This algorithm adjusts analog gain so that 8% to 13% of tap ROI pixels are above the specified target value.<br><b>2</b> = This algorithm adjusts analog gain so that the average pixel value in tap's ROI is equal to the specified target value.<br><b>3</b> = This algorithm adjusts digital gain so that the average pixel value in tap's ROI is equal to the specified target.<br><b>4</b> = This algorithm adjusts the analog gain so that the peak tap ROI pixels are adjusted to the specified target.<br><b>t</b> = Tap value. Use <b>0</b> for all taps or <b>1</b> or <b>2</b> for individual tap selection depending on camera model.<br><b>i</b> = Calibration target value in a range from <b>1024</b> to <b>4055DN</b> (12 bit LSB). |
| correction calibrate prnu | <b>ccp</b> |              | Performs PRNU calibration and eliminates the difference in responsivity between the most and least sensitive pixel creating a uniform response to light.  |

| Mnemonic                   | Syntax     | Parameters   | Description  |
|----------------------------|------------|--------------|--|
| calculate PRNU algorithm   | <b>cpa</b> | <b>i i</b>   | <p>Performs PRNU calibration according to the selected algorithm.</p> <p>The first parameter is the algorithm where <b>i</b> is:</p> <p><b>1</b> = This algorithm first adjusts each tap's analog gain so that 8-13% of pixels within a tap are above the value specified in the target value parameter. PRNU calibration then occurs using the peak pixel in the region of interest. (Identical to <b>ccp</b>)</p> <p><b>2</b> = Calculates the PRNU coefficients using the entered target value as shown below:</p> $\text{PRNU Coefficient} = \frac{\text{Target}}{(\text{AVG Pixel Value}) - (\text{FPN} + \text{sdo value})}$ <p>The calculation is performed for all sensor pixels but warnings are only applied to pixels in the region of interest. This algorithm is useful for achieving uniform output across multiple cameras.</p> <p><b>3</b> = This algorithm includes an analog gain adjustment prior to PRNU calibration. Analog gain is first adjusted so that the peak pixel value in tap's ROI is within 97 to 99% of the specified target value. It then calculates the PRNU coefficients using the target value as shown below:</p> $\text{PRNU Coefficient}_i = \frac{\text{Target}}{(\text{AVG Pixel Value}_i) - (\text{FPN}_i + \text{sdo value})}$ <p>The calculation is performed for all sensor pixels but warnings are only applied to pixels in the region of interest. This algorithm is useful for achieving uniform output across multiple cameras.</p> <p>The second parameter is the target value to use in a range from <b>1024</b> to <b>4055DN</b>.</p> |
| correction set sample      | <b>css</b> | <b>m</b>     | <p>Sets the number of lines to sample when using the <b>gla</b> command or when performing FPN and PRNU calibration where <b>m</b> is <b>256</b>, <b>512</b>, or <b>1024</b></p>   |
| display gpio configuration | <b>dgc</b> |              | <p>Displays the current configuration of the GPIO connector.</p>   |
| display pixel coeffs       | <b>dpc</b> | <b>x1 x2</b> | <p>Displays the pixel coefficients in the order FPN, PRNU, FPN, PRNU, ...</p> <p><b>x1</b> = Pixel start number</p> <p><b>x2</b> = Pixel end number</p> <p>in a range from <b>1</b> to <b>1024</b> or <b>2048</b></p>  |

| Mnemonic                  | Syntax     | Parameters | Description  |
|---------------------------|------------|------------|--|
| end of line sequence      | <b>els</b> | <b>i</b>   | Sets the end-of-line sequence:<br><b>0</b> : Off<br><b>1</b> : On  |
| enable pixel coefficients | <b>epc</b> | <b>i i</b> | Sets whether pixel coefficients are enabled or disabled.<br>The first parameter sets the FPN coefficients where <b>i</b> is:<br><b>0</b> = FPN coefficients disabled<br><b>1</b> = FPN coefficients enabled<br>The second parameter sets the PRNU coefficients where <b>i</b> is:<br><b>0</b> = PRNU coefficients disabled<br><b>1</b> = PRNU coefficients enabled |
| get camera model          | <b>gcm</b> |            | Reads the camera model number.   |
| get camera parameters     | <b>gcp</b> |            | Reads all of the camera parameters.  |
| get camera serial         | <b>gcs</b> |            | Read the camera serial number.   |
| get camera version        | <b>gcv</b> |            | Read the firmware version and FPGA version.  |
| get fpn coeff             | <b>gfc</b> | <b>x</b>   | Read the FPN coefficient<br><b>x</b> = pixel number to read in a range from <b>1 - sensor pixel count</b> .  |
| get help                  | <b>gh</b>  |            | Returns all of the available "get" commands.   |
| get line                  | <b>gl</b>  | <b>x x</b> | Gets a line of video (without pixel coefficients applied) displaying one pixel value after another and the minimum, maximum, and mean value of the sampled line.<br><b>x</b> = Pixel start number<br><b>x</b> = Pixel end number<br>in a range from <b>1 to sensor pixel count</b> .   |
| get line average          | <b>gla</b> | <b>x x</b> | Read the average of line samples.<br><b>x</b> = Pixel start number<br><b>x</b> = Pixel end number<br>in a range from <b>1 to sensor pixel count</b> .  |
| get prnu coeff            | <b>gpc</b> | <b>x</b>   | Read the PRNU coefficient.<br><b>x</b> = pixel number to read in a range from <b>1 - sensor pixel count</b> .  |
| get signal frequency      | <b>gsf</b> | <b>i</b>   | Reads the requested Camera Link control frequency.<br><b>1</b> = EXSYNC frequency<br><b>2</b> = Spare<br><b>3</b> = Direction<br><b>4</b> = Spare  |

| Mnemonic                 | Syntax     | Parameters     | Description  |
|--------------------------|------------|----------------|--|
| get status led           | <b>gs1</b> |                | Returns the current state of the camera's LED where:<br>1 = Red<br>2 = Green<br>5 = Blinking green<br>6 = Blinking red   |
| help                     | <b>h</b>   |                | Display the online help. Refer to Camera ASCII Command Help on page 54 for details.  |
| load pixel coefficients  | <b>lpc</b> |                | Loads the previously saved pixel coefficients from non-volatile memory where <b>i</b> is:<br>0 = Factory calibrated coefficients<br>1 = Coefficient set one<br>2 = Coefficient set two<br>3 = Coefficient set three<br>4 = Coefficient set four  |
| reset camera             | <b>rc</b>  |                | Resets the entire camera (reboot). Baud rate is not reset and reboots with the value last used.  |
| restore factory settings | <b>rfs</b> |                | Restores the camera's factory settings. FPN and PRNU coefficients reset to 0.  |
| region of interest       | <b>roi</b> | <b>x y x y</b> | Sets the pixel range affected by the <b>cag</b> , <b>cao</b> , <b>g1</b> , <b>gla</b> , <b>ccf</b> , and <b>ccp</b> commands. The parameters are the pixel start and end values ( <b>x</b> ) and the column start and end values ( <b>y</b> ) in a range from 1 to <b>sensor pixel count</b> . |
| reset pixel coeffs       | <b>rpc</b> |                | Resets the pixel coefficients to 0.  |
| restore user settings    | <b>rus</b> |                | Restores the camera's last saved user settings and FPN and PRNU coefficients.  |
| set analog gain          | <b>sag</b> | <b>t f</b>     | Sets the analog gain in dB.<br><b>t</b> = tap selection, either 1 or 2 depending on camera model, or 0 for all taps.<br><b>f</b> = gain value specified from -10 to +10  |
| set analog offset        | <b>sao</b> | <b>t i</b>     | Sets the analog offset.<br><b>t</b> = tap selection, either 1 or 2 depending on camera model, or 0 for all taps.<br><b>i</b> = Offset value in a range from 0 to 255 (12-bit LSB). Offset increases with higher values.  |
| set binning horizontal   | <b>sbh</b> | <b>m</b>       | Sets the horizontal binning value. Available values are 1 and 2.   |

| Mnemonic           | Syntax     | Parameters | Description   |
|--------------------|------------|------------|---|
| set baud rate      | <b>sbr</b> | <b>i</b>   | Set the speed of camera serial communication port. Baud rates: <b>9600</b> , <b>19200</b> , <b>57600</b> , and <b>115200</b> . Default: 9600.   |
| set ccd direction  | <b>scd</b> | <b>i</b>   | Sets the CCD shift direction where:<br><b>0</b> = Forward CCD shift direction.<br><b>1</b> = Reverse CCD shift direction.<br><b>2</b> = Externally controlled direction control via CC3.  |
| set data mode      | <b>sdm</b> | <b>i</b>   | Sets the camera's bit width where:<br><i>For SG-10-01K40 and SG-10-02K40</i><br><b>0</b> = 8 bits, 1 tap, 40MHz data rate<br><b>1</b> = 12 bits, 1 tap, 40MHz data rate<br><i>For SG-10-01K80 and SG-10-02K80</i><br><b>2</b> = 8 bits, 2 taps, 80MHz data rate<br><b>3</b> = 12 bits, 2 taps, 80MHz data rate  |
| set digital offset | <b>sdo</b> | <b>t i</b> | Subtracts the input value from the video signal prior to FPN correction.<br><b>t</b> = tap selection, either <b>1</b> or <b>2</b> depending on camera model, or <b>0</b> for all taps.<br><b>i</b> = Offset in a range from <b>0</b> to <b>2048DN</b> .   |
| set exposure mode  | <b>sem</b> | <b>m</b>   | Sets the exposure mode:<br><b>2</b> = Internal SYNC, internal PRIN, programmable line rate and exposure time using commands <b>ssf</b> and <b>set</b><br><b>3</b> = External SYNC, internal PRIN, maximum exposure time<br><b>4</b> = Smart EXSYNC<br><b>5</b> = External SYNC and PRIN<br><b>6</b> = External SYNC, internal PRIN, programmable exposure time<br><b>7</b> = Internal programmable SYNC, maximum exposure time. Factory setting.<br><b>8</b> = Internal SYNC, internal PRIN, programmable exposure time. Maximum line rate for exposure time. |
| set exposure time  | <b>set</b> | <b>f</b>   | Sets the exposure time. Refer to the camera help screen ( <b>h</b> command) for allowable range.  |
| set fpn coeff      | <b>sfc</b> | <b>x i</b> | Set the FPN coefficient.<br><b>x</b> = pixel number within the range <b>1</b> to <b>sensor pixel count</b> .<br><b>i</b> = FPN value within the range <b>0</b> to <b>2047</b> (12-bit LSB).   |

| Mnemonic                | Syntax     | Parameters | Description  |
|-------------------------|------------|------------|--|
| set GPIO input          | <b>sgi</b> | <b>i i</b> | Sets the GPIO input signal.<br><b>i</b> = input number in a range from <b>0</b> to <b>3</b><br><b>i</b> = signal to use where:<br><b>0</b> = disabled<br><b>1</b> = TTL<br><b>2</b> = LVDS   |
| set GPIO output         | <b>sgo</b> | <b>i i</b> | Sets the GPIO output signal.<br><b>i</b> = output number in a range from <b>0</b> to <b>3</b><br><b>i</b> = output signal to use where:<br><b>0</b> = disabled<br><b>1</b> = TTL<br><b>2</b> = LVDS  |
| set lower threshold     | <b>slt</b> | <b>i</b>   | The pixels below the lower threshold are checked for and reported in the end-of-line sequence in a range from <b>0-4095</b> .  |
| set prnu coeff          | <b>spc</b> | <b>x i</b> | Set the PRNU coefficient.<br><b>x</b> =pixel number within the range <b>1</b> to <b>sensor pixel count</b> .<br><b>i</b> = PRNU value within the range <b>0</b> to <b>28671</b> .  |
| set subtract background | <b>ssb</b> | <b>t i</b> | Subtract the input value from the output signal.<br><b>t</b> = Tap value. <b>0</b> for all taps or <b>1</b> to <i>number of camera taps</i> for individual tap selection.<br><b>i</b> = Subtracted value in a range from <b>0</b> to <b>4095</b> . |
| set sync frequency      | <b>ssf</b> | <b>i</b>   | Set the frame rate to a value from <b>300Hz</b> to <b>37000Hz</b> (2k model) or <b>300Hz</b> to <b>68000Hz</b> (1k model). Value rounded up/down as required.  |
| set system gain         | <b>ssg</b> | <b>t i</b> | Set the digital gain.<br><b>t</b> = tap selection, either <b>1</b> to <b>2</b> , or <b>0</b> for all taps<br><b>i</b> = Digital gain in a range from <b>0</b> to <b>65535</b> . The digital video values are multiplied by this number.            |
| set sensitivity mode    | <b>ssm</b> | <b>i</b>   | Sets the camera's sensitivity mode where <b>i</b> is:<br><b>0</b> = Low sensitivity mode<br><b>1</b> = High sensitivity mode<br><b>2</b> = Tall pixel mode   |
| set upper threshold     | <b>sut</b> | <b>i</b>   | The pixels equal to or greater than the upper threshold are checked for and reported in the end-of-line sequence in a range from <b>0-4095</b> .   |

| Mnemonic               | Syntax     | Parameters | Description   |
|------------------------|------------|------------|---|
| set video mode         | <b>svm</b> | <b>i</b>   | Switch between normal video mode and camera test patterns:<br>0: Normal video mode<br>1: Camera test pattern<br>2: Camera test pattern  |
| update gain reference  | <b>ugr</b> |            | Changes 0dB gain to equal the current analog gain value set with the <b>sag</b> command.  |
| verify temperature     | <b>vt</b>  |            | Check the internal temperature of the camera  |
| verify voltage         | <b>vv</b>  |            | Check the camera's input voltages and return OK or fail   |
| write FPN coefficients | <b>wfc</b> | <b>i</b>   | Write all current FPN coefficients to EEROM where <b>i</b> is:<br>1 = FPN coefficient set one<br>2 = FPN coefficient set two<br>3 = FPN coefficient set one<br>4 = FPN coefficient set two      |
| write PRNU coeffs      | <b>wpc</b> | <b>i</b>   | Write all current PRNU coefficients to EEROM where <b>i</b> is:<br>1 = PRNU coefficient set one<br>2 = PRNU coefficient set two<br>3 = PRNU coefficient set one<br>4 = PRNU coefficient set two |
| write user settings    | <b>wus</b> |            | Write all of the user settings to EEROM.  |

## A5 Error Handling

The following table lists warning and error messages and provides a description and possible cause. Warning messages are returned when the camera cannot meet the full value of the request; error messages are returned when the camera is unable to complete the request.

**Table 15: Warning and Error Messages**

| Message  | Description   |
|--|---|
| OK>  | SUCCESS   |
| Warning 01: Outside of specification>                                | Parameter accepted was outside of specified operating range (e.g. gain greater than $\pm 10$ dB of factory setting).  |
| Warning 02: Clipped to min>  | Parameter was clipped to the current operating range. Use <b>gcp</b> to see value used.   |
| Warning 03: Clipped to max>  | Parameter was clipped to the current operating range. Use <b>gcp</b> to see value used.   |
| Warning 04: Related parameters adjusted>                             | Parameter was clipped to the current operating range. Use <b>gcp</b> to see value used.   |
| Warning 05: Can't set LVDS for this GPIO signal                      | Input 3 and Output 3 cannot be set to use an LVDS signal.   |
| Warning 07: Coefficient may be inaccurate A/D clipping has occurred> | In the region of interest (ROI) greater than 6.251% single or 1% of averaged pixel values were zero or saturated.   |
| Warning 08: Greater than 1% of coefficients have been clipped>       | A FPN/PRNU has been calculated to be greater than the maximum allowable 511 (8).  |
| Warning 09: Internal line rate inconsistent with readout time>       |   |
| Message  | Description   |
| Error 02: Unrecognized command>                                      | Command is not available in the current access level or it is not a valid command.  |
| Error 03: Incorrect number of parameters>                            |   |
| Error 04: Incorrect parameter value>                                 | This response returned for <ul style="list-style-type: none"> <li>· Alpha received for numeric or vice versa</li> <li>· Not an element of the set of possible values. E.g., Baud Rate</li> <li>· Outside the range limit</li> </ul> |
| Error 05: Command unavailable in this mode>                          | Command is valid at this level of access, but not effective. Eg line rate when in smart EXSYNC mode   |

| Message   | Description  |
|---|--|
| Error 06: Timeout>  | Command not completed in time. Eg FPN/PRNU calculation when no external EXSYNC is present. |
| Error 07: Camera settings not saved>                                      | Tried saving camera settings ( <b>rfs/rus</b> ) but they cannot be saved.                  |
| Error 08: Unable to calibrate - tap outside ROI>                          | Cannot calibrate a tap that is not part of the region of interest.                         |
| Error 09: The camera's temperature exceeds the specified operating range> | Indicates that the camera has shut itself down to prevent damage from further overheating. |

# A6 Clearing Dark Current

## Gate Dark Current Clear

Image sensors accumulate dark current while they wait for a trigger signal. If the readout is not triggered in a reasonable amount of time, then this dark current accumulation may increase to an excessive amount. The result of this happening will be that the first row, and possibly additional rows (frames), of the image will be corrupt.

The sensor used in the Spyder 3 GigE camera contains two sources of dark current that will accumulate with time: 1) in the photo sensitive area, and 2) in the gates used to clock-out the charge.

The gate dark current can account for approximately 20% of the total dark current present. While the exposure control has direct control over the amount of dark current in the photo sensitive area, it has no control over the charge accumulated in the gates. Even with exposure control on, at low line rates, this gate charge can cause the camera to saturate.

Using the **Set Readout Mode (srm)** command, the camera user can control the camera's behavior in order to minimize the dark current artifact.

The modes of operation selected by the **srm** command are: Auto, On, or Off.

Note: This command is only available in low sensitivity and tall pixel modes. High sensitivity mode operates only in the immediate read out position.

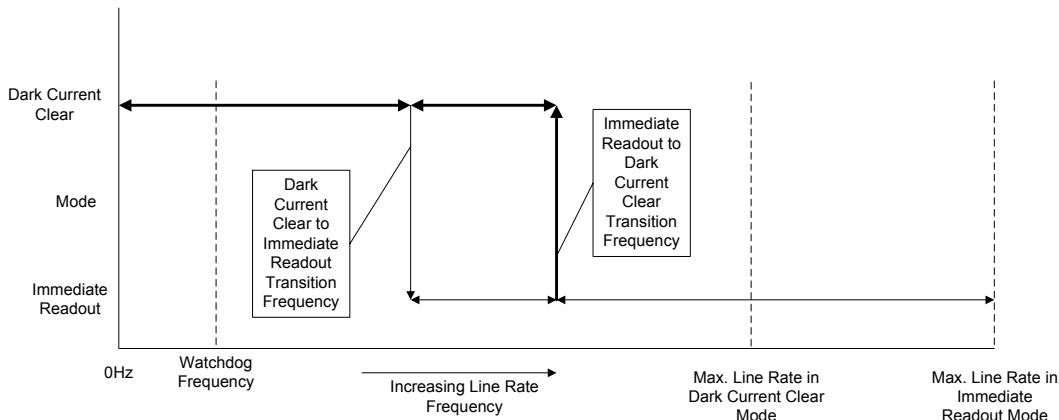

Figure 26: Gate Dark Current Clear

Table 16.

| Model       | Transition Frequencies                             |  |
|-------------|--|--|
|             | Dark Current Clear to Immediate Readout Transition | Immediate Readout to Dark Current Clear Transition |
| SG-10-01K40 | 13.6KHz  | 16.4KHz  |
| SG-10-01K80 | 25.1KHz  | 30.4KHz  |
| SG-10-02K40 | 7.05KHz  | 8.52KHz  |

|             |         |         |
|-------------|---------|---------|
| SG-10-02K80 | 13.6KHz | 16.4KHz |
|-------------|---------|---------|

## Immediate read out mode (default, srm 2)

In this mode the image is read out, including accumulated dark current, immediately following the trigger or the EXSYNC falling edge.

There are no line rate limitations other than the amount of gate dark current that can be tolerated at low line rates.

There are no timing or exposure anomalies other than situations where EXSYNC is removed from camera. In this case, the camera will operate in a "watchdog" state.

For information on artifacts that may be experienced while using this mode, see the Artifacts section below.

## Gate dark current clear mode (always on, srm 1)

In this mode the gate dark current will be cleared continuously.

After the trigger (EXSYNC) is received, the dark current is cleared from the image sensor before the image is acquired. The line rate is limited to  $\frac{1}{2}$  the maximum line rate available for that model of camera.

For information on artifacts that may be experienced while using this mode, see the Artifacts section below.

**Table 17.**

| Model       | Max. Line Rate         |                         |
|-------------|------------------------|-------------------------|
|             | Immediate Readout Mode | Dark Current Clear Mode |
| SG-10-01K40 | 36KHz                  | 18KHz                   |
| SG-10-01K80 | 68KHz                  | 34KHz                   |
| SG-10-02K40 | 18.5KHz                | 9.25KHz                 |
| SG-10-02K80 | 36KHz                  | 18KHz                   |

When operating in the dark current clear mode, there will be a slight delay, equivalent to one readout time, before the actual exposure is implemented. The actual exposure time will not be altered.

**Table 18.**

| Model       | Exposure Delay and Max Exposure Time in Auto Mode |
|-------------|---|
| SG-10-01K40 | 27.5 $\mu$ s                                      |
| SG-10-01K80 | 14.75 $\mu$ s                                     |
| SG-10-02K40 | 53.1 $\mu$ s                                      |
| SG-10-02K80 | 27.5 $\mu$ s                                      |

## Auto Mode (srm 0)

In this mode the line rate from the camera will automatically cause a switch between the gate dark current clear mode and non gate dark current clear mode.

The frequency of when this mode switchover occurs depends on the camera model.

In cases where the line rate is rapidly increased from below the Dark Current Clear to Immediate Readout Transition Frequency to above the Immediate Readout to Dark Current Clear Transition Frequency, the first line following this transition will likely be corrupted.

The table below outlines the artifacts that may be seen during this transition period. All subsequent lines after this occurrence will be as expected.

In the case of a slow transition (that is, when the EXSYNC line rate increases by less than 10% of the previous line rate) a line readout will not become corrupt.



There are also limitations on the exposure time when operating in auto mode: If the line rate exceeds half the maximum line rate, then the exposure time cannot exceed the time stated in Table 18.

Note: DALSA recommends Auto mode for most users.

For information on artifacts that may be experienced while using this mode, see the Artifacts section below.

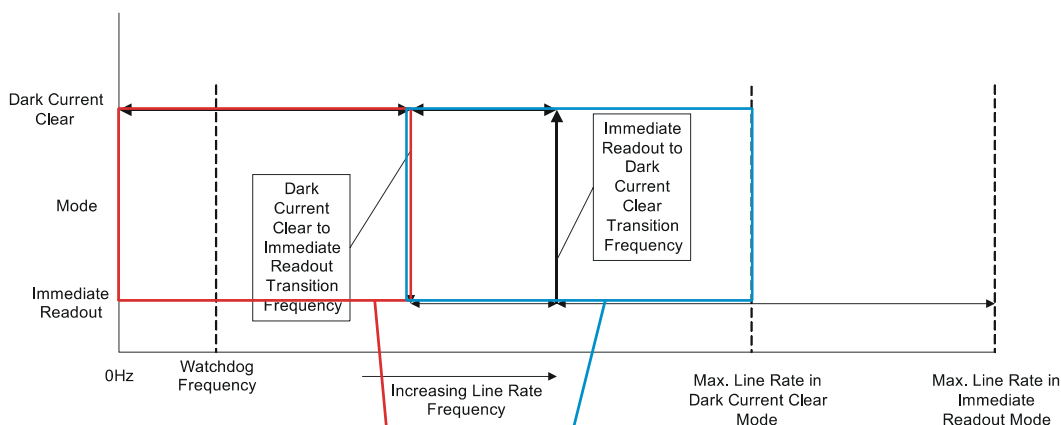
Please note: The graphic below explains the relationship between the following tables and the preceding Figure 26. The operating regions described in the tables refer to a specific region of Figure 26.



| SRM 0, Auto Mode. |   |                         |
|-------------------|---|-------------------------|
| Time Period       | Operating Region<br>Refer to the above figure                                       | Operating Mode          |
| T <sub>0</sub>    |  | Dark Current Dump state |
| T <sub>1</sub>    |  | Immediate Readout state |

Dark Current Dump to Immediate Readout: Multi-Line Artifacts.

| SRM 0, Auto Mode. |   |                         |
|-------------------|---|-------------------------|
| Time Period       | Operating Region<br>Refer to Figure 26. | Operating Mode          |
| T <sub>0</sub>    |   | Dark Current Dump state |
| T <sub>1</sub>    |   | Immediate Readout state |

| SRM 0, Auto Mode. |   |                         |
|-------------------|---|-------------------------|
| Time Period       | Operating Region<br>Refer to Figure 26. | Operating Mode          |
| T <sub>0</sub>    |   | Immediate Readout state |
| T <sub>1</sub>    |   | Dark Current Dump state |
| T <sub>2</sub>    |   | Immediate Readout state |

| SRM 2, Immediate Readout Mode. |   |                         |
|--------------------------------|---|-------------------------|
| Time Period                    | Operating Region<br>Refer to Figure 26. | Operating Mode          |
| T <sub>0</sub>                 |   | Dark Current Dump state |
| T <sub>1</sub>                 |   | Immediate Readout state |

Dark Current Dump to Immediate Readout (T<sub>INT</sub> < #)

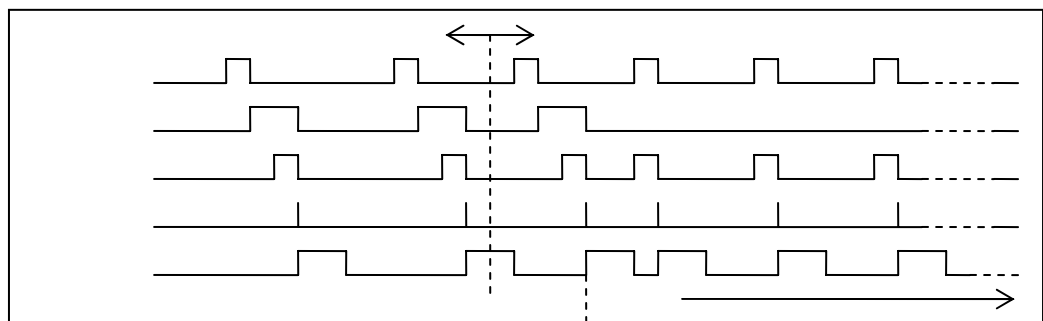

Dark Current Dump to Immediate Readout ( $T_{INT} > \#$ )

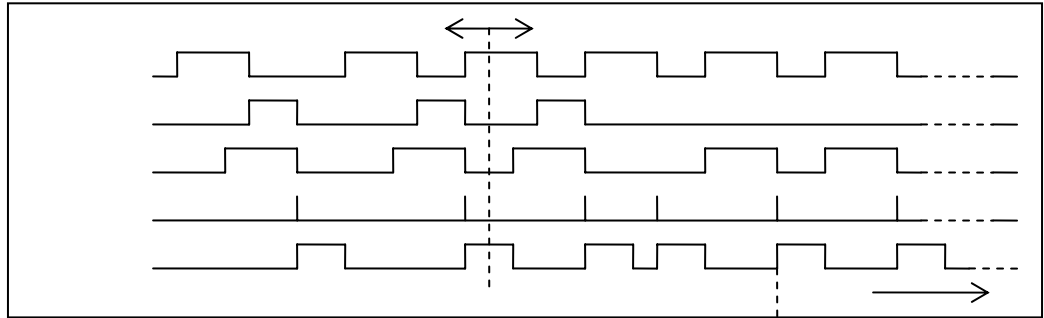

Dark Current Dump to Immediate Readout: Multi-Line Artifacts

| SRM 0, Auto Mode. |   |                         |
|-------------------|---|-------------------------|
| Time Period       | Operating Region<br>Refer to Figure 26. | Operating Mode          |
| T <sub>0</sub>    |   | Dark Current Dump state |
| T <sub>1</sub>    |   | Immediate Readout state |

| SRM 0, Auto Mode. |   |                         |
|-------------------|---|-------------------------|
| Time Period       | Operating Region<br>Refer to Figure 26. | Operating Mode          |
| T <sub>0</sub>    |   | Immediate Readout state |
| T <sub>1</sub>    |   | Dark Current Dump state |
| T <sub>2</sub>    |   | Immediate Readout state |

| SRM 2, Immediate Readout Mode. |   |                         |
|--------------------------------|---|-------------------------|
| Time Period                    | Operating Region<br>Refer to Figure 26. | Operating Mode          |
| T <sub>0</sub>                 |   | Dark Current Dump state |
| T <sub>1</sub>                 |   | Immediate Readout state |

Dark Current Dump to Immediate Readout ( $T_{INT} < \#$ )

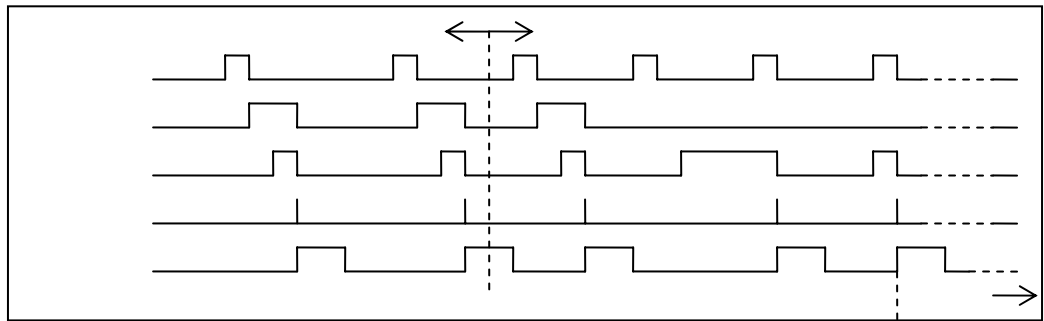

Dark Current Dump to Immediate Readout ( $T_{INT} > \#$ )

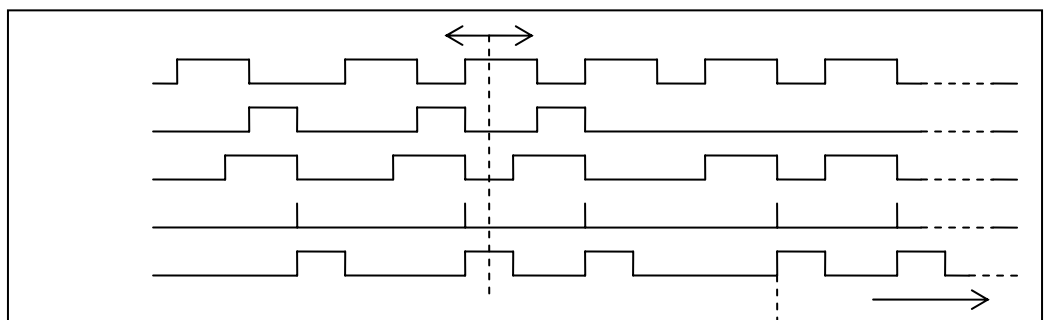

Immediate Readout to Dark Current Dump: Hysteresis Artifacts

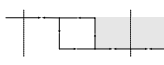
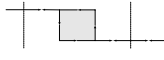
| SRM 0, Auto Mode. |   |                         |
|-------------------|---|-------------------------|
| Time Period       | Operating Region<br>Refer to Figure 26.   | Operating Mode          |
| T <sub>0</sub>    |  | Immediate Readout state |
| T <sub>1</sub>    |  | Dark Current Dump state |

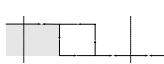
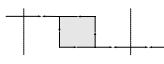
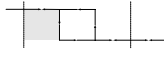
| SRM 0, Auto Mode. |   |                         |
|-------------------|---|-------------------------|
| Time Period       | Operating Region<br>Refer to Figure 26.   | Operating Mode          |
| T <sub>0</sub>    |  | Dark Current Dump state |
| T <sub>1</sub>    |  | Immediate Readout state |
| T <sub>2</sub>    |  | Dark Current Dump state |

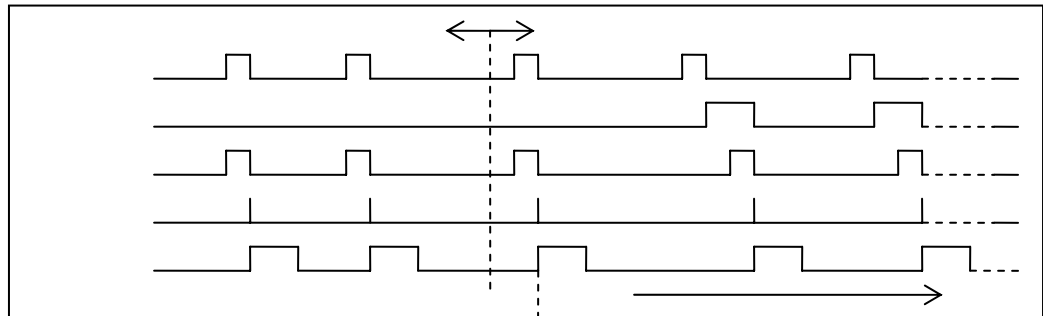

## Setting the Readout Mode

|                   |  |
|-------------------|--|
| Purpose:          | Use this command to clear out dark current charge in the vertical transfer gates immediately before the sensor is read out.  |
| Syntax:           | <b>srm</b>   |
| Syntax Elements:  | <b>i</b>   |
|                   | <p><b>0:</b> Auto. Clears dark current below ~ 45% of the maximum line rate.</p> <p><b>1:</b> Dark current clear. Always clears dark. Reduces the maximum line rate.</p> <p><b>2:</b> Immediate readout. Does not clear dark current. (Default mode.)</p>  |
| Notes:            | <ul style="list-style-type: none"> <li>• The vertical transfer gates collect dark current during the line period. This collected current is added to the pixel charge. The middle two red taps have more vertical transfer gates and, therefore, more charge. This additional charge is especially noticeable at slower line rates.</li> <li>• If the user is in <b>sem 2</b> or <b>7</b> and <b>srm 2</b>, with <b>ssf</b> at 45% of the maximum, and then <b>srm 1</b> is selected, the following warning will be displayed, but the <b>ssf</b> value will not be changed:<br/>Warning 09: Internal line rate inconsistent with readout time&gt;<br/>The effect in both internal and external line rate modes is that an EXSYNC is skipped and, therefore, the output will be at least twice as bright.</li> <li>• This value is saved with the camera settings.</li> <li>• This value may be viewed using either the <b>gcp</b> command or the get <b>srm</b> command.</li> </ul> |
| Related Commands: | <b>sem, ssf</b>  |
| Example:          | <b>srm 0</b>   |

# Appendix B

---

## EMC Declaration of Conformity

We, **DALSA**  
605 McMurray Rd.,  
Waterloo, ON  
CANADA N2V 2E9

declare under sole responsibility, that the product(s):

**SG-10-01K40-11E**  
**SG-10-01K80-11E**  
**SG-10-02K40-11E**  
**SG-10-02K80-11E**

fulfill(s) the requirements of the standard(s)

EMC: **CISPR-11:2004**  
**EN 55011:2003**  
**EN 61326:2002**

This product complies with the requirements of the Low Voltage Directive 73/23/EEC and the EMC Directive 89/336/EEC and carries the CE mark accordingly.

Place of Issue **Waterloo, ON, CANADA**

Date of Issue **August 2006**

Name and Signature  
of authorized person **Hank Helmond**  
**Quality Manager, DALSA Corp.**



This Declaration corresponds to EN 45 014.



# Appendix C

## Revision History

| Revision Number | Change Description   |
|-----------------|--|
| 00              | Initial release  |
| 01              | <p>Specification updates to Table 2.</p> <p>Updated Section 3.2 to show different methods of entering ASCII commands.</p> <p>Updated Section 3.4 replacing TBDs with values.</p> <p>Updated Section 4.1 to show inverted GPIO connector.</p> <p>Updated Help Screen in Camera ASCII Command Help section to show latest configuration of commands.</p> <p>Added line rate ranges to Setting the Line Rate section.</p> <p>Added sgi command.</p> <p>Removed Vertical Binning from example gcp screen in section A4.6.</p>  |
| 02              | <p>Updated random noise, PRNU, SEE, NEE, and DC Offset specifications in Table 2.</p> <p>Updated step 3 in section 2.1 Installation Overview with new driver installation tool instructions.</p> <p>Added that Windows 2000 with SP4 installed is necessary in section 2.2 PC Requirements.</p> <p>In section A1.1 Sensitivity Mode, corrected values for high and low sensitivity modes.</p> <p>In section A1.4 Setting the Exposure Mode updated exposure mode factory setting from 2 to 7.</p> <p>On page 65, in Calibrating Camera Gain and in Table 10: Command Quick Reference, updated algorithm 4.</p> <p>In section A3 Saving and Restoring Settings, added more detail about the different sets of user settings and pixel coefficients.</p> |
| 03              | <p>Added cpa command to section A2.2 Analog and Digital Signal Processing Chain and ASCII Commands: Reference</p> <p>Removed sgs command and updated sgi and sgo commands in section A1.5 Configuring the GPIO Connector and ASCII Commands: Reference.</p> <p>Added PRNU ECD specs to Table 2 and updated FPN global, PRNU ECD and DC offset specs.</p>   |
| 04              | <p>Section 2.1 Installation Overview: screenshots and procedure updated to reflect current version of the QuickCam GUI.</p> <p>Section 2.2 Equipment Recommendations: Ethernet shielded cable information added.</p>   |

| Revision Number | Change Description   |
|-----------------|--|
|                 | <p>Section 2.4 Camera Connectors: Ethernet shielded cable information added.</p> <p>Section 3.3 First Power Up Camera Settings: 500 Hz line rate changed to 5000 Hz. Note concerning FPN and PRNU coefficients' factory calibration change from 3.5 kHz line rate to 5 kHz.</p> <p>Section 4: Electrical interface information, including EMC requirements and shielded cable information, added to optical and mechanical considerations.</p> <p>Section 6.3 Product Support form: Control signals section changed to reflect GigE requirements.</p> <p>Section A4.1 Ethernet test pattern revised. Ethernet test pattern only available using the QuickCam application.</p> <p>Section A4.7 Returning Camera Settings: GCP Screen updated.</p> <p>Appendix B: EMC Declaration of Conformity: "Pending" stamp removed. Products covered by the declaration and EMC requirements listed.</p> |
| 05              | <p>-Page 24, mechanical updated. GPIO connector corrected to female connector from the incorrect male connector.</p> <p>-Page 25, Table 5: GPIO Connector Pinout, inputs and outputs corrected to read 0 to 3, and not 1 to 4 as stated in earlier versions.</p> <p>-"Preliminary" stamp removed from user manual.</p>   |
| 06              | <p>-Revised dynamic range: Up to 1400 : 1.</p> <p>-Added dark current clear information and setting the readout mode (srm) command description to Appendix A.</p> <p>-Revised camera mechanical, page 38. Ethernet connector reversed, revised dimensions for connectors on back plate.</p> <p>-Revised the gcp command results screen to include the srm command.</p> <p>-ASCII reference revised to include srm command.</p>   |

---

# Index

## A

analog  
  gain, 67, 68  
  offset, 69  
  processing, 66  
applications, 6

## B

background subtract, 77  
bright lines, 50

## C

calibrating the camera, 70, 73,  
  76, 77  
camera  
  dimensions, 38  
  messages, 101  
camera settings. *See* settings  
coefficients  
  disabling, 79  
  enabling, 79  
  loading, 79  
  resetting, 79  
command  
  format, 53  
  parameters, 53  
commands  
  list, 95  
connectors, 23  
  Hirose, 25  
  power, 25

## D

dark calibration. *See* flat field  
  correction  
Dark Current  
  Clearing, 103  
dark patches, 50  
data rate, 8  
debugging, 47  
digital  
  gain, 78  
  offset, 74  
  processing, 66  
  signal processing, 73

direction  
  externally controlled, 56, 57  
  web movement, 12  
driver  
  comparison, 23  
  High Performance, 22  
  Standard Mode, 22  
  Universal IP, 23

## E

electrical  
  compliance, 40  
  specs, 8  
EMC compliance, 40  
EMC Declaration of  
  Conformity, 111  
end-of-line sequence, 80  
error messages, 101  
Ethernet  
  cables, 40  
exposure mode  
  overview, 58  
  setting, 57  
  timing, 58  
exposure time  
  setting, 62, 63, 64  
EXSYNC  
  troubleshooting, 48

## F

fiber-optic light sources, 39  
filters, 39  
flat field correction  
  errors, 79  
  performing, 72  
  restrictions, 70  
  results, 79  
FPN  
  coefficient, 73  
  correction, 73

## G

gain, 6, 68  
  analog, 67  
  calibrating, 67  
  digital, 78  
  reference, 69

**H**

halogen light sources, 39  
 help, 54  
 High Performance Driver, 22  
 Hirose connector, 25  
 hot mirror, 39

**I**

illumination, 39  
 incorrect line rate, 50  
 input/output, 23  
 interface  
   electrical, 8  
   mechanical, 7  
   optical, 7, 39

**L**

LED, 27  
 lens  
   modeling, 39  
 light calibration. *See* flat field  
   correction  
 light sources, 39  
 line dropout, 50  
 line rate, 8  
   setting, 62  
 line statistics, 85

**M**

magnification, 40  
 mechanical  
   drawing, 38  
 mechanical specs, 7  
 mode  
   performance, 22  
   standard, 22  
   Universal IP Filter Driver Mode,  
   23  
 models, 7  
 modes  
   default, 60

**N**

network adapter, 20  
 noisy output, 50

**O**

offset  
   analog, 68  
   calibrating, 69  
   digital, 74  
 online help, 54

operating  
   modes, 57  
 optical interface, 39  
 optical specs, 7  
 outputs  
   TTL, 26, 65

**P**

performance mode, 22  
 performance specifications, 10–  
 12  
 pixel statistics, 85  
 power  
   connectors, 25  
   guidelines, 25  
   supply, 25  
 PRNU  
   coefficient, 77  
   correction, 76  
 product support, 52

**R**

readout mode  
   auto, 105  
   default, 104  
   gate dark current clear, 104  
   immediate, 104  
   setting, 61, 110  
 rebooting, 84  
 requirements  
   Ethernet switch, 21  
   fiber-optic interface, 21  
   network adapter, 20  
 resolution, 7  
 restoring  
   coefficients, 83  
   factory settings, 82  
 roi. *See* Region of Interest

**S**

saving  
   coefficients, 83  
 sensor, 9  
   cleaning, 44  
 serial interface  
   defaults, 53  
 settings  
   factory, 35  
   restoring, 82  
   returning, 88, 91  
   saving, 82  
 shielded cables  
   compliance, 40  
 standard mode, 22  
 statistics, 85  
 subtracting background, 77

sync frequency, 87

## T

Technical Sales Support, 52

temperature

measurement, 87

test patterns, 84

threshold

lower, 81

upper, 81

timing

mode 7, 60

troubleshooting, 47

TTL

outputs, 26, 65

## U

Universal IP Filter Driver

Mode, 23

## V

video data, 86

voltage

measurement, 87

## W

warning messages, 101