

PULNiX TM-1010

Progressive Scan High Resolution Shutter Camera

Product Features

- Very high resolution 1" progressive scan interline transfer CCD imager (1008H x 1018V)
- 10-bit digital output for progressive scan (RS-422)
- 15 frame/sec. at 20 MHz clock speed, or selectable at 10 MHz or 5 MHz clock speed
- Full-frame shutter ...1/60 to 1/16,000 sec.
- Asynchronous reset with external shutter control
- Frame memory built-in for async image capture
- Full frame integration with uninterrupted video
- Excellent S/N (>60 dB at CDS)
- RS-232C external control for gain, A/D reference, dynamic range control

General Description

The PULNiX TM-1010 is a very high resolution monochrome progressive scan camera with many features. The interline transfer CCD imager has a square imager format (1") with symmetrical pixels, resulting in consistent image definition in any orientation. The electronic shutter, which has speeds selectable to 1/16,000 sec., asynchronously resets by external pulse control. The TM-1010 has its own built-in frame store which can capture and output full-frame images in real time.

Specifically designed for low noise and high resolution image capturing, the single channel output produces outstanding shutter and integration characteristics. The scanning clock rate is adjustable to optimize noise relative to scanning speed.

This versatile camera is particularly easy to set up and use. Externally controlled gain and dynamic range adjustments offer added convenience when varying the imaging parameters of the CCD. All functions are remotely controllable via RS-232C communication. Special interface cables are available for connecting the TM-1010 directly to many existing commercial frame grabbers. 10-bit, RS-644 digital signal output permits interfacing with external image processing systems.*

Applications for the TM-1010 include medical and scientific imaging, high definition graphics, on-line inspection, gauging, character reading, archiving, and long range image acquisition.

Asynchronous Reset

The TM-1010's asynchronous reset is flexible and takes external horizontal drive (HD) for phase locking. CCD scanning and purging is reset by applying the VINIT pulse. There are three modes to control the asynchronous reset and shutter speed:

1. **External VINIT with pulse width.** The duration between pulse edges controls the shutter speed (1/16,000 to 4 sec.).

2. **Internal shutter speed with Fast mode.** The



video signal has no delay from the reset timing. The shutter speed range is 1/2,000 to 1/16,000 sec.

3. **Internal shutter speed with Slow mode.** The speed control can be varied from 1/125 to 1/1,000 sec., with a standard output of 15 fps. The video signal starts with internal V reset timing related to shutter speed. The built-in frame memory maintains the asynchronously captured full frame image until the next VINIT pulse comes in.

Integration

The CCD imager of the TM-1010 can be exposed longer than normal scan timing (1/15 sec.). Integration is achieved by controlling the #11 pin of the 12-pin connector to Low (GND) or by using VINIT pulse width control up to 10 sec. This integration feature provides high sensitivity for dark environment applications.

The internal frame memory provides continuous video output without interruption during the integration period. The progressive scanning CCD chip permits a full frame of resolution in non-interlace format. Designed for low noise, the integration mode and the slower clock scanning with 10-bit output make this camera suitable for a variety of applications.

Electronic Shutter

The TM-1010 has a substrate drain shutter which allows a superb picture at various speeds without a smearing effect. Electronic shutter speeds of 1/60, 1/125, 1/250, 1/500, 1/1,000, 1/2,000, 1/4,000, 1/8,000, or 1/16,000 second are selectable via the built-in manual speed control.

With VINIT high (5V), the CCD keeps discharging. With a negative going pulse to VINIT, the camera resets and purges the charge momentarily. Then it starts integrating for the period set by either external pulse width or internal shutter control. Unlike conventional CCD cameras which allow only half lines per shutter, progressive scanning produces a full 1000 lines of vertical resolution per single shutter.

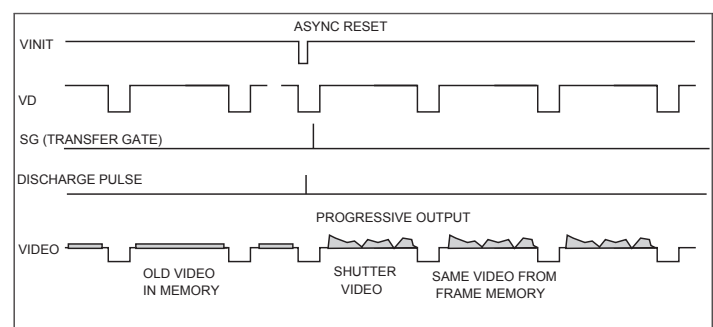

* LVD, FDV, Clock are RS-422

Specification

Imager	1" (9.1mm x 9.2mm) progressive scan interline transfer CCD
Pixel	1008 (H) x 1018 (V)
Cell Size	9.0µm x 9.0 µm
Scanning	1050 lines; 15 Hz
Sync	Internal/External Auto Switch HD/VD, 4.0 Vp-p impedance 4.7Ω VD=15 Hz ± 5%, non-interlace HD= 15.734 kHz ± 3%
Data Clock Output	20.034 MHz (std), 10 and 5 MHz selectable
S/N Ratio	60 dB at CDS
Min. Illumination	1.0 lux, f-1.4 without IR cut filter (no shutter). Sensitivity: 10µV/e-
Video Output	Digital 10-bit RS-644 output LDV, FDV, CLK RS-422 Analog 1.0 Vp-p composite video, 75Ω
AGC	OFF
Gamma	1.0
Lens Mount	C-mount
Power Requirement	12V DC, 700mA
Operating Temperature	-10° C to 50° C
Vibration	7Grms (10 to 2000 Hz)
Shock	70G
Size (W x H x L)	51.2mm x 67.4mm x 151.2mm (2.02" x 2.65" x 5.95")
Weight	462g w/o tripod mount (tripod mount is 60g)
Auto Iris Connector	None
Functional Options	OP-89-1 (Full LVDS Digital Output)
Accessories	DC-31 31-pin mating connector; 30DG-02-40 digital cable, CD-232 RS-232 cable & software 12P-02S PD-12UU Series

Dimensions

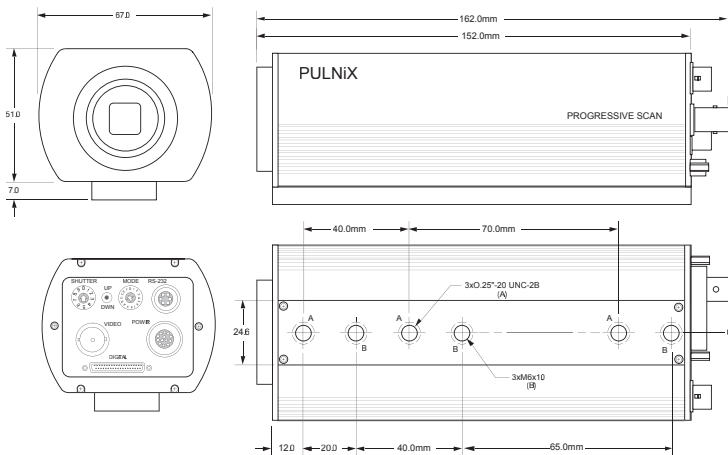

JAI A-S, Denmark
Phone +45 4457 8888
www.jai.com

JAI UK Ltd., England
Phone: +44 189 582 1481
www.jai.com

JAI Corporation, Japan
Phone: +81 045 440 0150
www.jai-corp.co.jp

JAI PULNiX, Germany
Phone +49-(0) 60 55-93 79-0
www.jaipulnix.com

JAI PULNiX Inc., USA
1330 Orleans Drive
Sunnyvale
CA 94089
USA

Phone +1 408-747-0300
(toll-free) 1 800 445 5444
Fax +1 408 747 0660
www.jaipulnix.com

Pin Configurations

31-Pin Connector (MP211-031-113-4300)

Pin#	Description	I/O	Pin#	Description	I/O
1	CLK+	Out	17	CLK-	Out
2	LDV+	Out	18	LDV-	Out
3	FDV+	Out	19	FDV-	Out
4	GND		20	VINIT/VD	In
5	EXT HD	In	21	INTEG	In
6	D0+	Out	22	D0-	Out
7	D1+	Out	23	D1-	Out
8	D2+	Out	24	D2-	Out
9	D3+	Out	25	D3-	Out
10	D4+	Out	26	D4-	Out
11	D5+	Out	27	D5-	Out
12	D6+	Out	28	D6-	Out
13	D7+	Out	29	D7-	Out
14	D8+	Out	30	D8-	Out
15	D9+	Out	31	D9-	Out
16	GND	Shield			

Note: CLK: data clock, LDV: Line data valid, FDV: Frame data valid, VINIT: async trigger, INTEG: integration control

6-Pin Connector RS-232C Communication

- 1 RXD
- 2 TXD
- 3 RTS
- 4 GND
- 5 GND
- 6 GND

Control and report functions

12-Pin Connector

- | | |
|---------|-------------|
| 1 GND | 7 VD in |
| 2 +12V | 8 GND |
| 3 GND | 9 HD in |
| 4 Video | 10 GND |
| 5 GND | 11 Int.cont |
| 6 VINIT | 12 GND |

Mode Control Switch

0	Normal mode	
1	Gain control	up/down
2	Async/man shutter	up:manual,dwn:async
3-4	Gain selection (9dB - 28 dB)	up/down
5	Clock selection (20, 10, 5 MHz)	up/down
6	A/D ref low	up/down
7	A/D ref high	up/down
8	Freeze (ENINT) enable	up:real time,dwn:freeze
9	Factory set recall	
A-F	User page storage (store user settings)	

Shutter Control Switch

	Manual	Async
0	no shutter	no shutter
1	1/60	1/16,000
2	1/125	1/8,000
3	1/250	1/4,000
4	1/500	1/2,000
5	1/1,000	1/1,000
6	1/2,000	1/500
7	1/4,000	1/250
8	1/8,000	1/125
9	1/16,000	Ext. pulse width

Covered by patent #6259478B1



PULNiX
www.jaipulnix.com