

**Digital Monochrome (b/w)
Progressive Scan Camera**

 System: **IEEE1394b**
Baumer TXD06

 Art. No: **OD107734**

- FireWire™ – IEEE1394b (800 Mbit / sec) progressive scan CCD camera
- 776 x 582 pixel
- Up to 64 full frames per second
- Outstanding image quality
- High sensitivity and dynamic range
- High quality slow scan mode for lowest readout noise
- Binning and true partial scan function (ROI) for increased frame rates
- External synchronization via industrial compliant process interface (trigger / flash)
- Integrated 32 MByte RAM for temporarily image data buffering
- Ultra compact and lightweight aluminum housing
- Bilingual: FireWire™ – IEEE1394b and IEEE1394a compatible
- Screw-lock type industrial connector
- Baumer-GAPI: Flexible, generic software interface for Windows
- DCAM (IIDC V1.31) compatible Baumer driver / Baumer OHCI driver



shown lens needs to be ordered separately

1. Overview

Sensor	1/2" interline progressive scan CCD
Shutter / readout mode	global shutter / progressive scan readout
Number of pixel	776 x 582
Scan area	6.47 mm x 4.83 mm
Pixel size	8.3 µm x 8.3 µm
Color filter	-
Operation modes	
Trigger mode	yes, overlapped operation
Free running mode	yes, overlapped operation
Signal processing	software programmable
Pixel clock	40 MHz fast scan / 20 MHz high quality (HQ) scan
A/D converter	12 bit
Exposure control (t _{exp})	total: 4 µsec .. 60 sec step 1 µsec
Gain control	manual control: 0 .. 20 dB
Offset (black level) / brightness control	manual control: 0 .. 255 LSB (12 bit)
Image data buffer	32 MByte
Image acquisition	
One / multi shot function	yes
Data format / color coding	Mono8, Mono16

Technical specifications subject to change

Camera image format modes	Resolution / description	Color coding	Bit per pixel	Pixel clock MHz	Frames per sec. *)	t _{readout}
Format 0 Mode 5	640 x 480 center scan fast scan	Mono8	8	40	120 (74) **, 60, 30, 15, 7.5, 3.75, 1.875	13.5 msec
Format 0 Mode 6	640 x 480 center scan high quality scan	Mono16	16	20	60 (37.5) **, 30, 15, 7.5, 3.75, 1.875	26.5 msec
Format 7 Mode 0	776 x 582 full frame high quality scan	Mono8	8	20	32 block size 4 .. 3792 Byte	31 msec
		Mono16	16			
Format 7 Mode 1	776 x 582 full frame fast scan	Mono8	8	40	64 block size 4 .. 7616 Byte	15.5 msec
		Mono16	16			
Format 7 Mode 2	388 x 291 binning 2x2 high quality scan	Mono8	8	20	64 block size 4 .. 1896 Byte	15.5 msec
		Mono16	16			
Format 7 Mode 3	388 x 291 binning 2x2 fast scan	Mono8	8	40	127 block size 4 .. 3784 Byte	8 msec
		Mono16	16			
Partial scan function	yes, format freely programmable in all Format 7 modes					
Advanced feature						
Look up table	on request: user programmable (input 12 bit, output 12 bit / 8 bit) or Gamma					
Test pattern function	yes					
Brightness correction	yes, optional in all binning modes					
Image info header	no					
Start / stop camera	yes					
Data quality	at 20 °C, gain = 0 dB, exposure time = 32 msec, Format 7 Mode 0					
Readout noise	$\sigma < 0.5$ LSB (8 bit) typical					
Dynamic range	typical > 54 dB					
Optical interface	C-Mount on request: CS-Mount					
Optical filter	dust protection on request: super polished, IR cut filter, daylight filter or no filter					
Process interface functions						
Async. trigger	yes, trigger mode operation, software trigger and external trigger in trigger mode 0					
External flash sync / Strobe_0	yes delay_value ≤ 4 µsec, duration_value (t _{duration}): slow mode = t _{exp} + 49 µsec fast mode = t _{exp} + 25 µsec					
Software reset / initialize camera	yes, delay up to 102 msec					
Electrical interface						
Data / control / power	standard single cable IEEE1394b bilingual / 9 pins option: screw lock type connector					
Digital input	1: trigger signal, opto decoupled U _{IN(low)} = 0 .. 4.5 VDC, U _{IN(high)} = 11 .. 30 VDC I _{IN} = 20 mA (typical) rising edge (polarity bit = "1") *** min. trigger impulse length (t _{min}): 2 µsec trigger delay out of t _{readout} (t _{delay trigger}): 4 µsec max. trigger delay during t _{readout} (t _{delay trigger}): slow mode = 49 µsec fast mode = 25 µsec					
Digital output	1: flash sync signal, opto decoupled U _{EXT} = 5 .. 30 VDC / 24 VDC typical, I _{OUT} = 16 mA **** high active (polarity bit = "1") *** flash delay (t _{delay flash}): ≤ 4 µsec					
LED	green: power on / yellow: data transmission active					
Power consumption	VCC: 8 .. 33 V I: 300 mA .. 100 mA approx. 3 Watt					

Technical specifications subject to change

Environmental	
Storage temperature	-10 °C .. +70 °C
Operating temperature	+5 °C .. +50 °C between +39 °C .. +50 °C, note the max. housing temperature
Housing operating temperature	max. +50 °C ***** (measurement point, see item 6)
Humidity	10 % .. 90 % non condensing
Conformity	CE, FCC Part 15 class B, RoHS
Housing	aluminum
Dimensions	36 x 36 x 48 mm ³
Weight	< 90 g
IEEE1394 interface	800 / 400 / 200 / 100 Mbit / sec
Software	DCAM (IIDC V1.31) compatible Baumer FCAM1394 driver (Baumer OHCI driver) / Software Development Kit (SDK) for Windows 2000 / Windows XP / Windows Vista DCAM (IIDC V1.31) compatible IEEE1394 programs and image processing libraries supported Windows / Linux depending on the actually driver software is used

- *) maximum frame rate in free running mode, effective frame rate depending on camera image format mode settings, set block size and set exposure time (texp < treadout)
- **) possible frame rates which can be achieved in the selected mode, see item 2.
- ***) can be inverted via software
- ****) necessary for optimal timing specification
- *****) housing temperature is limited by CCD sensor specification

2. Selectable Frame Rates depending on the used IEEE1394 Interface

Format	Mode	IEEE1394 interface	240 fps	120 fps	60 fps	30 fps	15 fps	7.5 fps	3.75 fps	1.875 fps
0	5	800 Mbit / sec		x (74) *)	x	x	x	x	x	x
		400 Mbit / sec			x	x	x	x	x	x
		200 Mbit / sec				x	x	x	x	x
	6	100 Mbit / sec					x	x	x	x
		800 Mbit / sec			x (37.5) *)	x	x	x	x	x
		400 Mbit / sec				x	x	x	x	x
		200 Mbit / sec				x	x	x	x	
		100 Mbit / sec					x	x	x	

- *) possible frame rates which can be achieved in the selected mode

3. Camera Factory Settings after Camera Start-up

	Camera factory settings after camera start-up
Operation modes	free running mode
Signal processing	
Exposure control	32 msec
Gain control	factor 1 = 0 dB
Offset (black level) / brightness control	0
Image acquisition	
Camera image format mode	Format 0 Mode 5 / 15 fps
Partial scan function	not active
Electrical interface	
Flash sync signal / Strobe_0	disabled, digital output set to low status (high impedance) polarity bit = "1"
Async. trigger	disabled polarity bit = "1"

4. Supported Image Formats via fxlib.dll (Baumer FCAM driver)

Camera name		TXD06				
Camera mode		SDK image mode				
	Color coding	Mode ID	Image format	Description	Color coding	Functions / State
Format 0 Mode 5	Mono8	05	640 x 480	center scan fast scan	RawMono8, Mono8	T, F
Format 0 Mode 6	Mono16	06	640 x 480	center scan high quality scan	RawMono8, Mono8, RawMono12, Mono12	T, F
Format 7 Mode 0	Mono8	070	776 x 582	full frame Mono8 high quality scan	RawMono8, Mono8	PS, T, F
	Mono16	570	776 x 582	full frame Mono16 high quality scan	RawMono8, Mono8, RawMono12, Mono12	PS, T, F
Format 7 Mode 1	Mono8	071	776 x 582	full frame Mono8 fast scan	RawMono8, Mono8	PS, T, F
	Mono16	571	776 x 582	full frame Mono16 fast scan	RawMono8, Mono8, RawMono12, Mono12	PS, T, F
Format 7 Mode 2	Mono8	072	388 x 291	binning 2x2 Mono8 high quality scan	RawMono8, Mono8	PS, T, F, BRC
	Mono16	572	388 x 291	binning 2x2 Mono16 high quality scan	RawMono8, Mono8, RawMono12, Mono12	PS, T, F, BRC
Format 7 Mode 3	Mono8	073	388 x 291	binning 2x2 Mono8 fast scan	RawMono8, Mono8	PS, T, F, BRC
	Mono16	573	388 x 291	binning 2x2 Mono16 fast scan	RawMono8, Mono8, RawMono12, Mono12	PS, T, F, BRC

- SDK - Software Development Kit
- BRC - brightness correction
- PS - partial scan
- T - trigger
- F - flash

Mono8 [16] - camera image data for monochrome camera modes in 8 [16] bit

RawMono8 [12] - unmanipulated pixel data for monochrome camera modes in 8 [12] bit

Mono8 [12] - software corrected image data for monochrome camera modes in 8 [12] bit

5. Timing Operation Modes

Trigger Mode: start up time

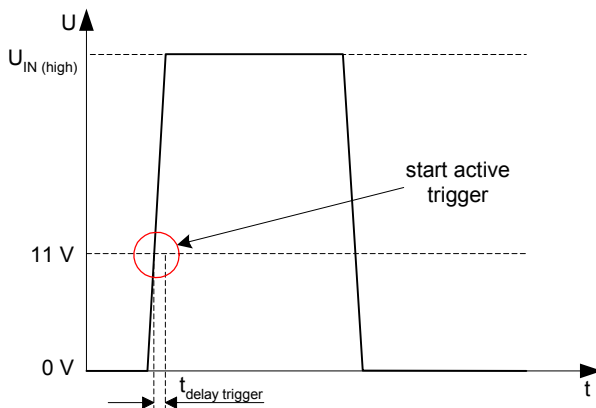

Trigger Mode: trigger mode 0, overlapped trigger

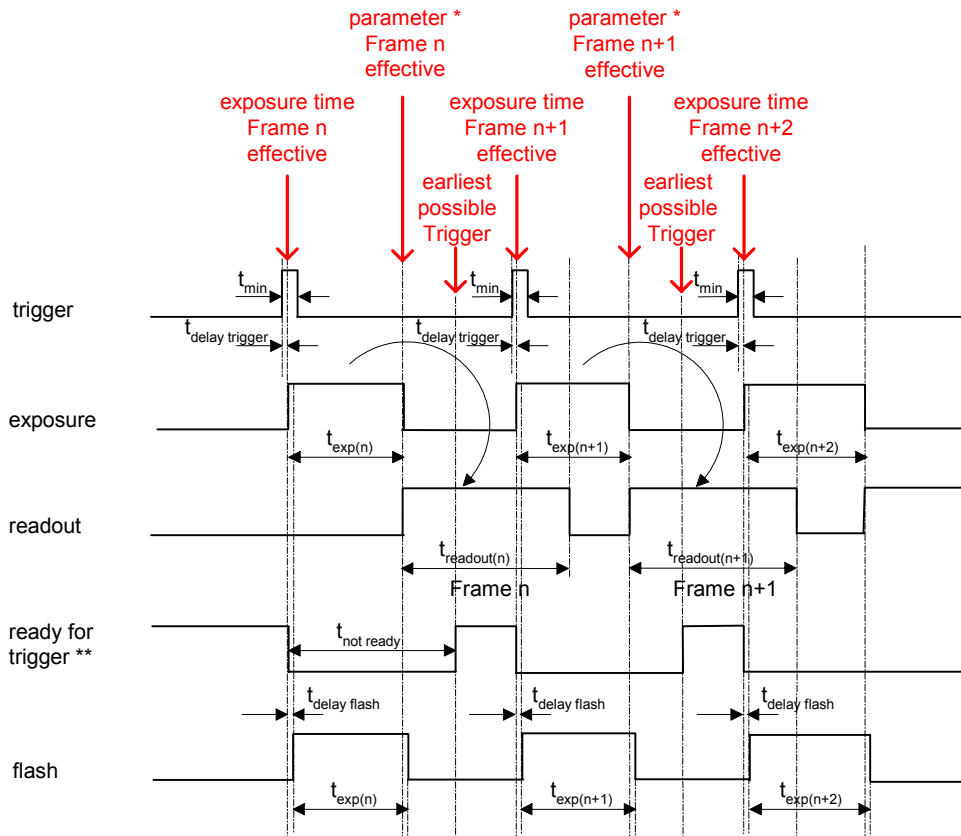

$$t_{exp} < t_{readout}: t_{\text{earliest possible trigger (n+1)}} = t_{readout(n)} - t_{exp(n+1)}$$

$$t_{exp} > t_{readout}: t_{\text{earliest possible trigger (n+1)}} = t_{exp(n)}$$

$$t_{exp} < t_{readout}: t_{\text{not ready (n+1)}} = t_{exp(n)} + t_{readout(n)} - t_{exp(n+1)}$$

$$t_{exp} > t_{readout}: t_{\text{not ready (n+1)}} = t_{exp(n)}$$

* image parameter: offset
global gain
mode
partial scan

** signal is not available as digital output

Trigger Mode: trigger mode 0, overlapped trigger , when $t_{exp(n+2)} > t_{exp(n+1)}$

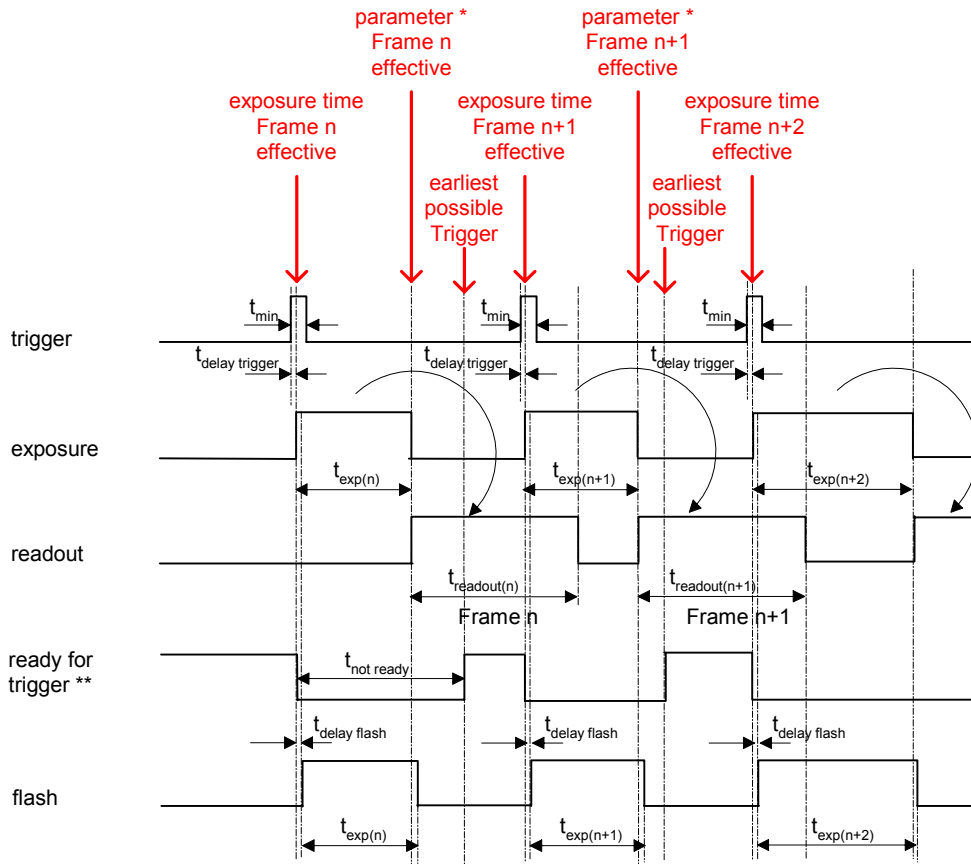

$$t_{exp} < t_{readout}: t_{earliest\ possible\ trigger\ (n+1)} = t_{readout(n)} - t_{exp(n+1)}$$

$$t_{exp} > t_{readout}: t_{earliest\ possible\ trigger\ (n+1)} = t_{exp(n)}$$

$$t_{exp} < t_{readout}: t_{not\ ready\ (n+1)} = t_{exp(n)} + t_{readout(n)} - t_{exp(n+1)}$$

$$t_{exp} > t_{readout}: t_{not\ ready\ (n+1)} = t_{exp(n)}$$

* image parameter: offset
global gain
mode
partial scan

** signal is not available as digital output

Trigger Mode: trigger mode 0, overlapped trigger , when $t_{exp(n+2)} < t_{exp(n+1)}$

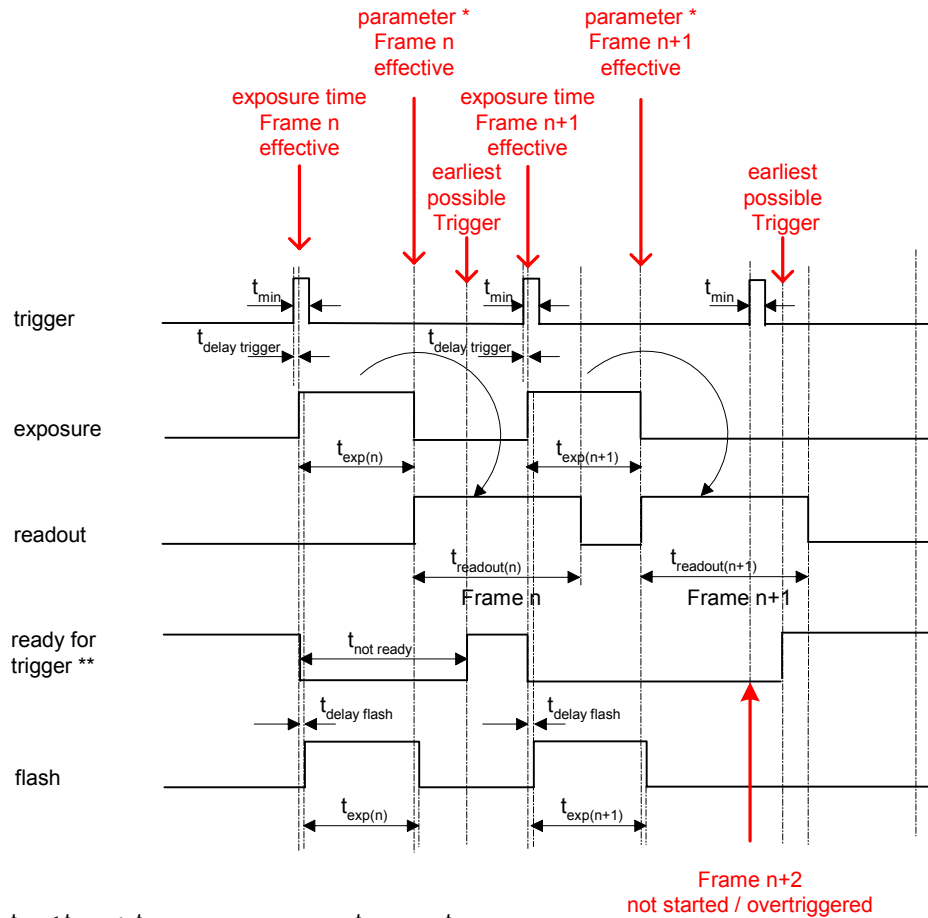

$$t_{exp} < t_{readout}: t_{earliest\ possible\ trigger\ (n+1)} = t_{readout(n)} - t_{exp(n+1)}$$

$$t_{exp} > t_{readout}: t_{earliest\ possible\ trigger\ (n+1)} = t_{exp(n)}$$

$$t_{exp} < t_{readout}: t_{not\ ready\ (n+1)} = t_{exp(n)} + t_{readout(n)} - t_{exp(n+1)}$$

$$t_{exp} > t_{readout}: t_{not\ ready\ (n+1)} = t_{exp(n)}$$

* image parameter: offset
global gain
mode
partial scan

** signal is not available as digital output

Free Running Mode: overlapped operation

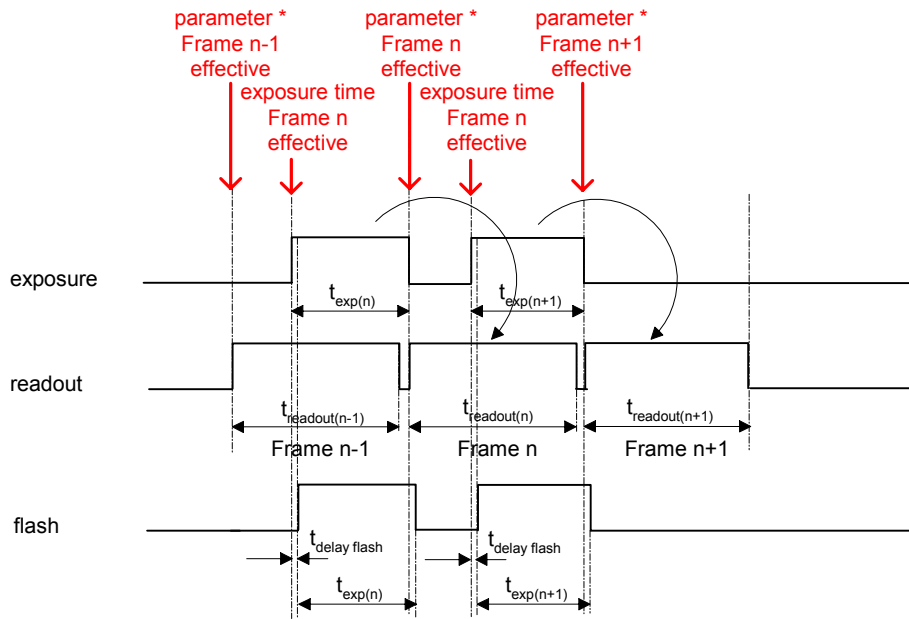

* image parameter: offset
 global gain
 mode
 partial scan

6. Housing

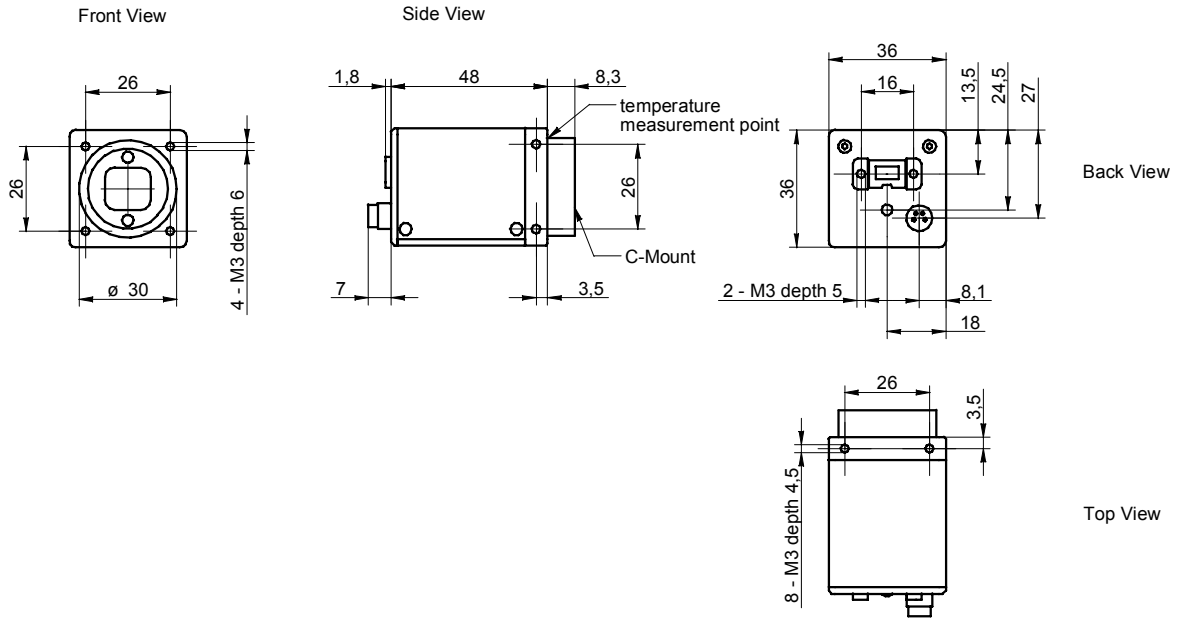

7. Connectors / Electrical Interfaces

7.1 Pin assignment:

IEEE1394b	Pin
	1: TPB- 2: TPB+ 3: TPA- 4: TPA+ 5: GND A 6: GND Power 7: not used 8: Voltage Power 9: GND B

Trigger Flash	Type: Lumberg RSMESD 4pin.
	<p>*) resistor must be used, $I_{OUT} = 16 \text{ mA}$ by $U_{EXT} = 24 \text{ VDC}$ recommended, drawing shown above example for using high active signal</p>
	<p>Trigger / Flash cable wires color *): 1 = brown 2 = white 3 = blue 4 = black</p>

*) shielded trigger / flash cable should to be used and ordered separately

7.2 Flash sync sample $U_{EXT} = 24\text{ VDC}$ high active:

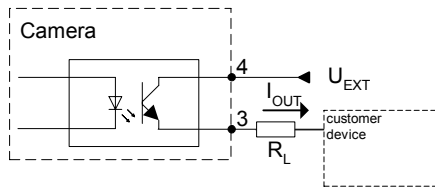

Timing example:
 measurement condition $U_{EXT} = 24\text{ VDC} / I_{OUT} = 16\text{ mA}$

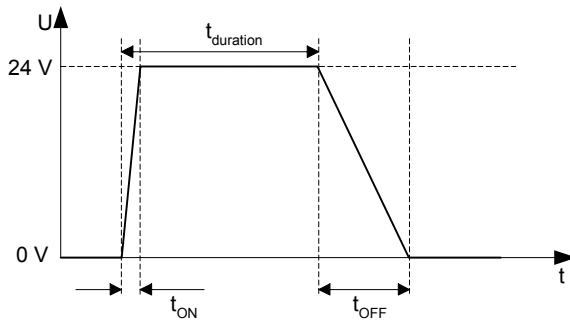

t_{ON} time = typ. 2 μsec
 t_{OFF} time = typ. 40 μsec

7.3 Flash sync sample $U_{EXT} = 24\text{ VDC}$ low active:

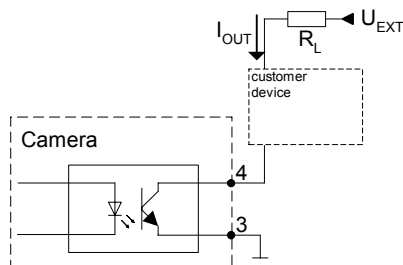

Timing example:
 measurement condition $U_{EXT} = 24\text{ VDC} / I_{OUT} = 16\text{ mA}$

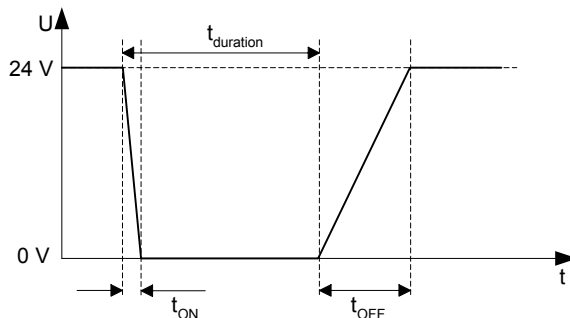

t_{ON} time = typ. 2 μsec
 t_{OFF} time = typ. 40 μsec

End of Document

Technical specifications subject to change