

**Digital Color
Progressive Scan Camera**

 System: **IEEE1394b**
Baumer TXD13c

 Art. No: **OD107730**

- FireWire™ – IEEE1394b (800 Mbit / sec) progressive scan CCD camera
- 1384 x 1032 pixel
- Up to 20 full frames per second
- On board integrated color processor for high quality color calculation
- Outstanding image quality and color fidelity
- High sensitivity and dynamic range
- High quality slow scan mode for lowest readout noise
- True partial scan function (ROI) for increased frame rates
- External synchronization via industrial compliant process interface (trigger / flash)
- Integrated 32 MByte RAM for temporarily image data buffering
- Ultra compact and lightweight aluminum housing
- Bilingual: FireWire™ – IEEE1394b and IEEE1394a compatible
- Screw-lock type industrial connector
- Baumer-GAPI: Flexible, generic software interface for Windows
- DCAM (IIDC V1.31) compatible Baumer driver / Baumer OHCI driver



shown lens needs to be ordered separately

1. Overview

Sensor	1/2" interline progressive scan CCD
Shutter / readout mode	global shutter / progressive scan readout
Number of pixel	1392 x 1040
Scan area	6.4 mm x 4.8 mm
Pixel size	4.65 µm x 4.65 µm
Color filter	RGB Bayer mosaic
Operation modes	
Trigger mode	yes, overlapped operation
Free running mode	yes, overlapped operation
Signal processing	software programmable
Pixel clock	40 MHz fast scan / 20 MHz high quality (HQ) scan
A/D converter	12 bit
Exposure control (t_{exp})	total: 4 µsec .. 60 sec step 1 µsec
Gain control	manual control: 0 .. 20 dB
Offset (black level) / brightness control	manual control: 0 .. 255 LSB (12 bit)
Image data buffer	32 MByte
Image acquisition	
One / multi shot function	yes
Data format / color coding	YUV8, Mono8, Mono16, Raw8, Raw16

Technical specifications subject to change

Camera image format modes	Resolution / description	Color coding	Bit per pixel	Pixel clock MHz	Frames per sec. *)	t _{readout}
Format 2 Mode 0	1280 x 960 center scan high quality scan	YUV (4:2:2)	16	20	15 (10.5 **), 7.5, 3.75, 1.875	94.5 msec
Format 2 Mode 2	1280 x 960 center scan fast scan	Mono8	8	40	30 (21 **), 15, 7.5, 3.75, 1.875	47.5 msec
Format 7 Mode 0	1392 x 1040 full frame high quality scan	Raw8 ***)	8	20	10 block size 4 .. 3624 Byte	100 msec
		Raw16 ***)	16			
Format 7 Mode 1	1392 x 1040 full frame fast scan	Raw8 ***)	8	40	20 block size 4 .. 7248 Byte	50 msec
		Raw16 ***)	16			
Format 7 Mode 2	1384 x 1032 full frame high quality scan	Mono8	8	20	10 block size 4 .. 5384 Byte	100 msec
		4:1:1 YUV8	12			
		4:2:2 YUV8	16			
		4:4:4 YUV8	24			
Format 7 Mode 3	1384 x 1032 full frame fast scan	Mono8	8	40	20 block size 4 .. 7248 Byte	50 msec
		4:1:1 YUV8	12			
		4:2:2 YUV8	16			
		4:4:4 YUV8	24			
Partial scan function	yes, format freely programmable in all Format 7 modes					
Advanced feature						
Look up table	on request: user programmable (input 12 bit, output 12 bit / 8 bit) or Gamma					
Test pattern function	yes					
Image info header	no					
Start / stop camera	yes					
Data quality	at 20 °C, gain = 0 dB, exposure time = 32 msec, Format 7 Mode 0					
Readout noise	$\sigma < 0.5$ LSB (8 bit) typical					
Dynamic range	typical > 54 dB					
Optical interface	C-Mount on request: CS-Mount					
Optical filter	Hoya E-CM500S on request: super polished, dust protection, daylight filter or no filter					
Process interface functions						
Async. trigger	yes, trigger mode operation, software trigger and external trigger in trigger mode 0					
External flash sync / Strobe_0	yes delay_value ≤ 4 μ sec, duration_value (t _{duration}): slow mode = t _{exp} + 94 μ sec fast mode = t _{exp} + 47 μ sec					
Software reset / initialize camera	yes, delay up to 102 msec					
Electrical interface						
Data / control / power	standard single cable IEEE1394b bilingual / 9 pins option: screw lock type connector					
Digital input	1: trigger signal, opto decoupled U _{IN(low)} = 0 .. 4.5 VDC, U _{IN(high)} = 11 .. 30 VDC I _{IN} = 20 mA (typical) rising edge (polarity bit = "1") ****) min. trigger impulse length (t _{min}): 2 μ sec trigger delay out of t _{readout} (t _{delay trigger}): 5 μ sec max. trigger delay during t _{readout} (t _{delay trigger}): slow mode = 94 μ sec fast mode = 47 μ sec					
Digital output	1: flash sync signal, opto decoupled U _{EXT} = 5 .. 30 VDC / 24 VDC typical, I _{OUT} = 16 mA ****) high active (polarity bit = "1") ****) flash delay (t _{delay flash}): ≤ 4 μ sec					
LED	green: power on / yellow: data transmission active					
Power consumption	VCC: 8 .. 33 V I: 300 mA .. 100 mA approx. 3 Watt					

Technical specifications subject to change

Environmental	
Storage temperature	-10 °C .. +70 °C
Operating temperature	+5 °C .. +50 °C between +38 °C .. +50 °C, note the max. housing temperature
Housing operating temperature	max. +50 °C ***** (measurement point, see item 6)
Humidity	10 % .. 90 % non condensing
Conformity	CE, FCC Part 15 class B, RoHS
Housing	aluminum
Dimensions	36 x 36 x 48 mm ³
Weight	< 90 g
IEEE1394 interface	800 / 400 / 200 / 100 Mbit / sec
Software	IIDC V1.31 (DCAM) compatible Baumer FCAM1394 driver (Baumer OHCI driver) / Software Development Kit (SDK) for Windows 2000 / Windows XP / Windows Vista IIDC V1.31 (DCAM) compatible IEEE1394 programs and image processing libraries supported Windows / Linux depending on the actually driver software is used

- *) maximum frame rate in free running mode, effective frame rate depending on camera image format mode settings, set block size and set exposure time (texp < treadout)
- **) possible frame rates which can be achieved in the selected mode, see item 2.
- ***) raw color data can be used via the mono color coding ID
- ****) can be inverted via software
- *****) necessary for optimal timing specification
- *****) housing temperature is limited by CCD sensor specification

2. Selectable Frame Rates depending on the used IEEE1394 Interface – to be revised

Format	Mode	IEEE1394 interface	240 fps	120 fps	60 fps	30 fps	15 fps	7.5 fps	3.75 fps	1.875 fps
2	0	800 Mbit / sec					x (10.5) *)	x	x	x
		400 Mbit / sec						x	x	x
		200 Mbit / sec							x	x
		100 Mbit / sec								x
	2	800 Mbit / sec				x (21) *)	x	x	x	x
		400 Mbit / sec					x	x	x	x
		200 Mbit / sec						x	x	x
		100 Mbit / sec							x	x

- *) possible frame rates which can be achieved in the selected mode

3. Camera Factory Settings after Camera Start-up

	Camera factory settings after camera start-up
Operation modes	free running mode
Signal processing	
Exposure control	32 msec
Gain control	factor 1 = 0 dB
Offset (black level) / brightness control	0
Image acquisition	
Camera image format mode	Format 2 Mode 0 / 3.75 fps
White balance	active, adjusted on light source value = 5000 K (D50)
Partial scan function	not active
Electrical interface	
Flash sync signal / Strobe_0	disabled, digital output set to low status (high impedance) polarity bit = "1"
Async. Trigger	disabled polarity bit = "1"

4. Supported Image Formats via fxlib.dll (Baumer FCAM driver)

4.1 Supported Image Format

Camera name		TXD13c			
Camera mode		SDK image mode			
	Color coding	Mode ID	Image format	Description	Functions / State
Format 2 Mode 0	YUV (4:2:2)	20	1280 x 960	center scan high quality scan	T, F
Format 2 Mode 2	Mono8	22	1280 x 960	center scan fast scan	T, F
Format 7 Mode 0	Raw8 *)	070	1392 x 1040	full frame Raw8 high quality scan	PS, T, F
	Raw16 *)	570	1392 x 1040	full frame Raw16 high quality scan	PS, T, F
Format 7 Mode 1	Raw8 *)	071	1392 x 1040	full frame Raw8 fast scan	PS, T, F
	Raw16 *)	571	1392 x 1040	full frame Raw16 fast scan	PS, T, F
Format 7 Mode 2	Mono8	072	1384 x 1032	full frame Mono8 high quality scan	PS, T, F
	4:1:1 YUV8	172	1384 x 1032	full frame 4:1:1 YUV high quality scan	PS, T, F
	4:2:2 YUV8	272	1384 x 1032	full frame 4:2:2 YUV high quality scan	PS, T, F
	4:4:4 YUV8	372	1384 x 1032	full frame 4:4:4 YUV high quality scan	PS, T, F
	RGB8	472	1384 x 1032	full frame RGB8 high quality scan	PS, T, F
Format 7 Mode 3	Mono8	073	1384 x 1032	full frame Mono8 fast scan	PS, T, F
	4:1:1 YUV8	173	1384 x 1032	full frame 4:1:1 YUV fast scan	PS, T, F
	4:2:2 YUV8	273	1384 x 1032	full frame 4:2:2 YUV fast scan	PS, T, F

*) raw color data can be used via the mono color coding ID

4.2 Software supported / Calculated Color Coding

		Supported / calculated color coding via software							
Baumer-GAPI		Bayer RG8	Bayer RG12	BGR8 Packed	BGR12 Packed	RGB8 Planar	RGB12 Planar	Mono8	Mono12
API Fxlib		Bayer8	Bayer12	Color 3x8x1	Color 3x12x1	Color 1x8x3	Color 1x12x3	Mono8	Mono12
Pixel coding camera	Raw8	x *)							
	Raw16	x	x *)						
	Mono8							x *)	
	YUV (4:1:1)			x				x	
	YUV (4:2:2)			x				x	
	YUV (4:4:4)			x				x	
	RGB8			x *)				x	

*) original camera format

4.3 Abbreviation / Description

SDK	- Software Development Kit
PS	- partial scan
T	- trigger
F	- flash
Mono	- monochrome mode
Color	- color mode
Raw8[16]	- unmanipulated pixel data in Bayer filter pattern in 8 [16] bit
Bayer8[12] / BayerRG8[12]	- unmanipulated pixel data in Bayer filter pattern in 8 [12] bit
Color3x8[12] / RGB8[12] Packed	- software corrected image data for color camera modes in the color data arrangement BGR in 24[36] bit
Color1x8[12]x3 / RGB8[12] Planar	- software corrected image data for color camera modes in the color data arrangement RRR...GGG...BBB in 3x8[12] bit
RGB8	- camera calculated image data for color camera modes in the color data arrangement RGB in 24 bit
YUV (4:1:1)	- camera calculated image data for color camera modes in the color data arrangement YUV (4:1:1) in 12 bit
YUV (4:2:2)	- camera calculated image data for color camera modes in the color data arrangement YUV (4:2:2) in 16 bit
YUV (4:4:4)	- camera calculated image data for color camera modes in the color data arrangement YUV (4:4:4) in 24 bit
Mono8[12]	- camera or software calculated image data for monochrome camera modes in 8[16] bit

5. Timing Operation Modes

Trigger Mode: start up time

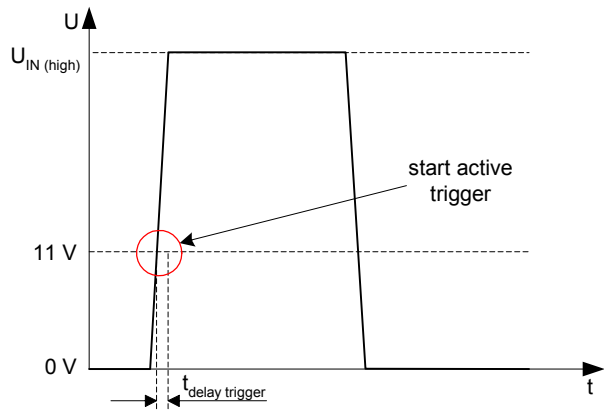

Trigger Mode: trigger mode 0, overlapped trigger

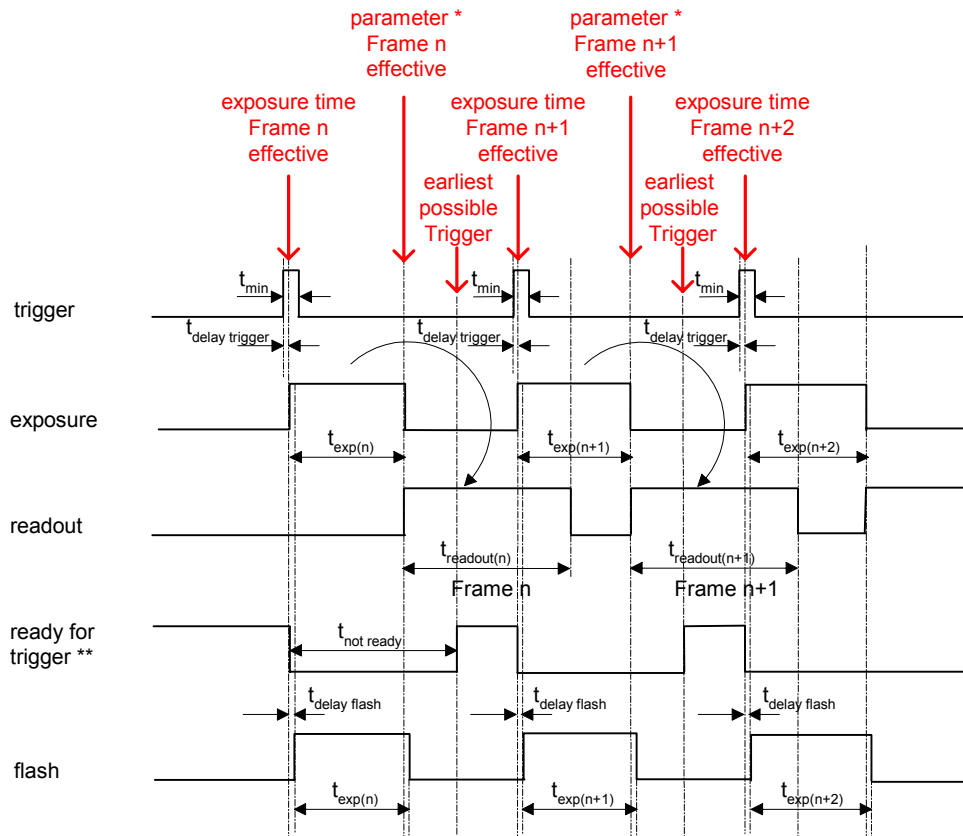

$$\begin{aligned}
 t_{\text{exp}} < t_{\text{readout}}: t_{\text{earliest possible trigger (n+1)}} &= t_{\text{readout}(n)} - t_{\text{exp}(n+1)} \\
 t_{\text{exp}} > t_{\text{readout}}: t_{\text{earliest possible trigger (n+1)}} &= t_{\text{exp}(n)} \\
 t_{\text{exp}} < t_{\text{readout}}: t_{\text{not ready (n+1)}} &= t_{\text{exp}(n)} + t_{\text{readout}(n)} - t_{\text{exp}(n+1)} \\
 t_{\text{exp}} > t_{\text{readout}}: t_{\text{not ready (n+1)}} &= t_{\text{exp}(n)}
 \end{aligned}$$

* image parameter: offset
global gain
mode
partial scan

** signal is not available as digital output

Trigger Mode: trigger mode 0, overlapped trigger , when $t_{exp(n+2)} > t_{exp(n+1)}$

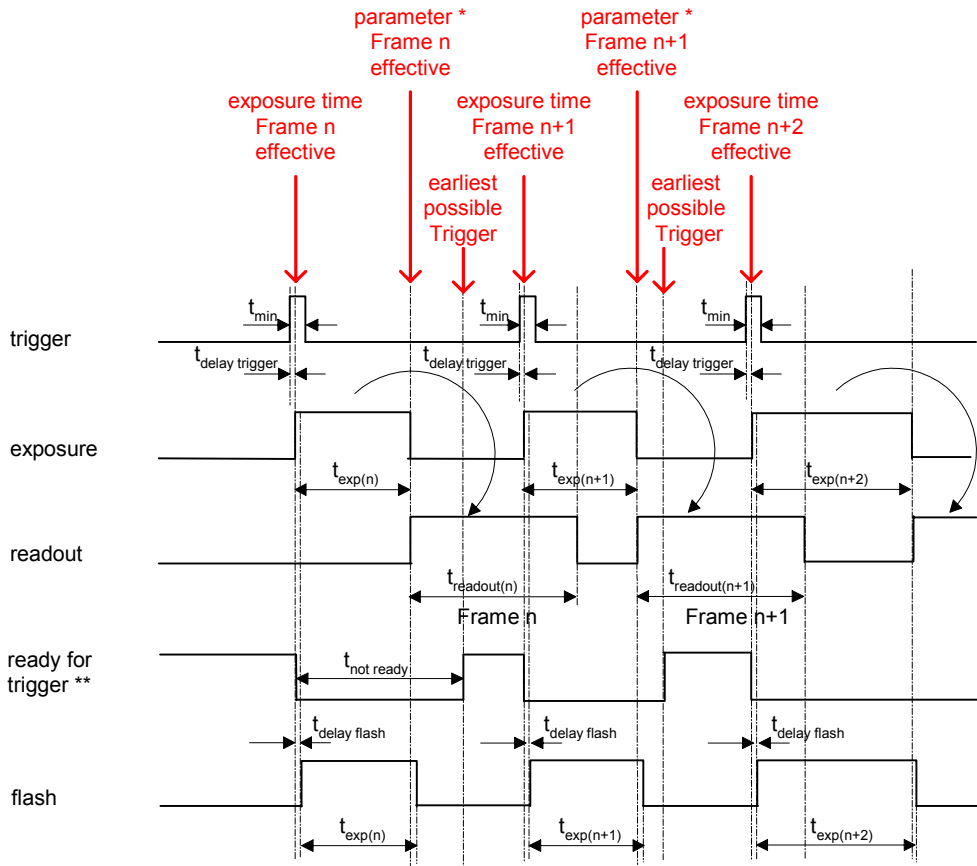

$$t_{exp} < t_{readout}: t_{earliest\ possible\ trigger\ (n+1)} = t_{readout(n)} - t_{exp(n+1)}$$

$$t_{exp} > t_{readout}: t_{earliest\ possible\ trigger\ (n+1)} = t_{exp(n)}$$

$$t_{exp} < t_{readout}: t_{not\ ready\ (n+1)} = t_{exp(n)} + t_{readout(n)} - t_{exp(n+1)}$$

$$t_{exp} > t_{readout}: t_{not\ ready\ (n+1)} = t_{exp(n)}$$

* image parameter: offset
 global gain
 mode
 partial scan

** signal is not available as digital output

Trigger Mode: trigger mode 0, overlapped trigger , when $t_{exp(n+2)} < t_{exp(n+1)}$

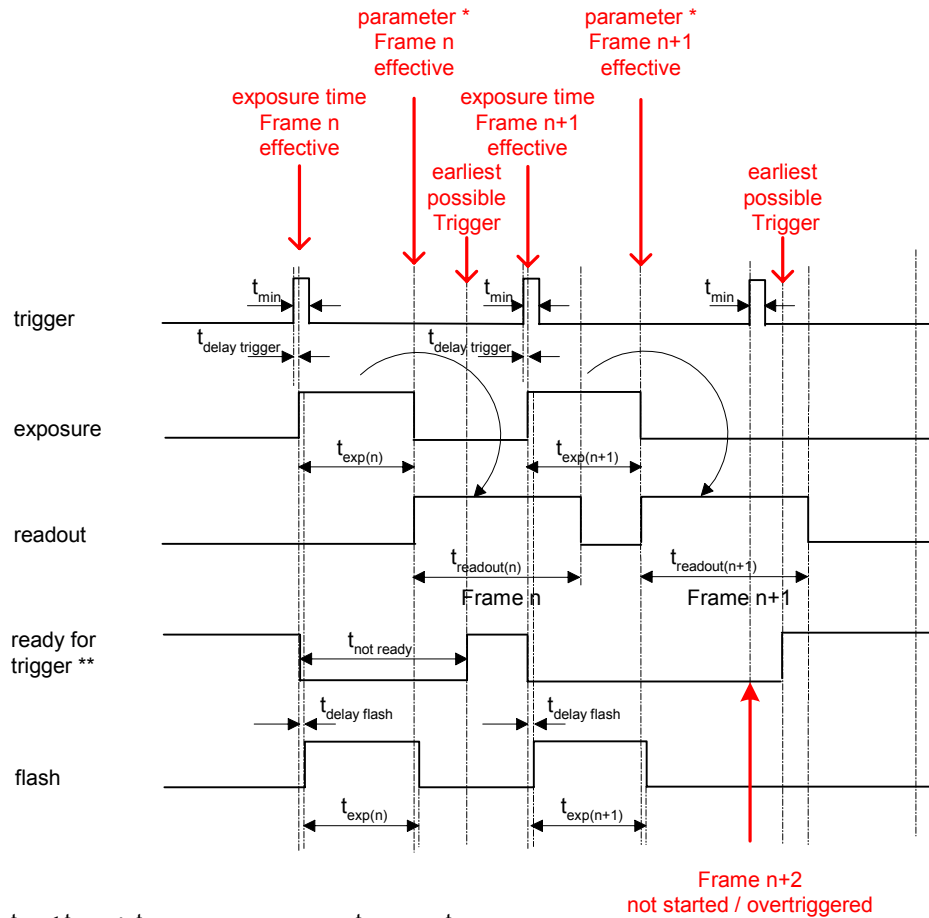

$$t_{exp} < t_{readout}: t_{earliest\ possible\ trigger\ (n+1)} = t_{readout(n)} - t_{exp(n+1)}$$

$$t_{exp} > t_{readout}: t_{earliest\ possible\ trigger\ (n+1)} = t_{exp(n)}$$

$$t_{exp} < t_{readout}: t_{not\ ready\ (n+1)} = t_{exp(n)} + t_{readout(n)} - t_{exp(n+1)}$$

$$t_{exp} > t_{readout}: t_{not\ ready\ (n+1)} = t_{exp(n)}$$

* image parameter: offset
global gain
mode
partial scan

** signal is not available as digital output

Free Running Mode: overlapped operation

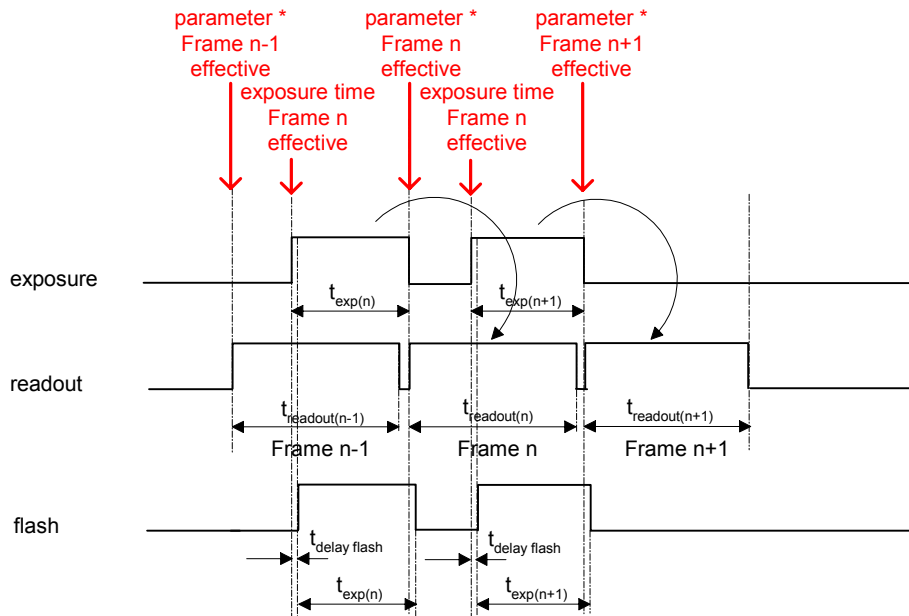

* image parameter: offset
 global gain
 mode
 partial scan

6. Housing

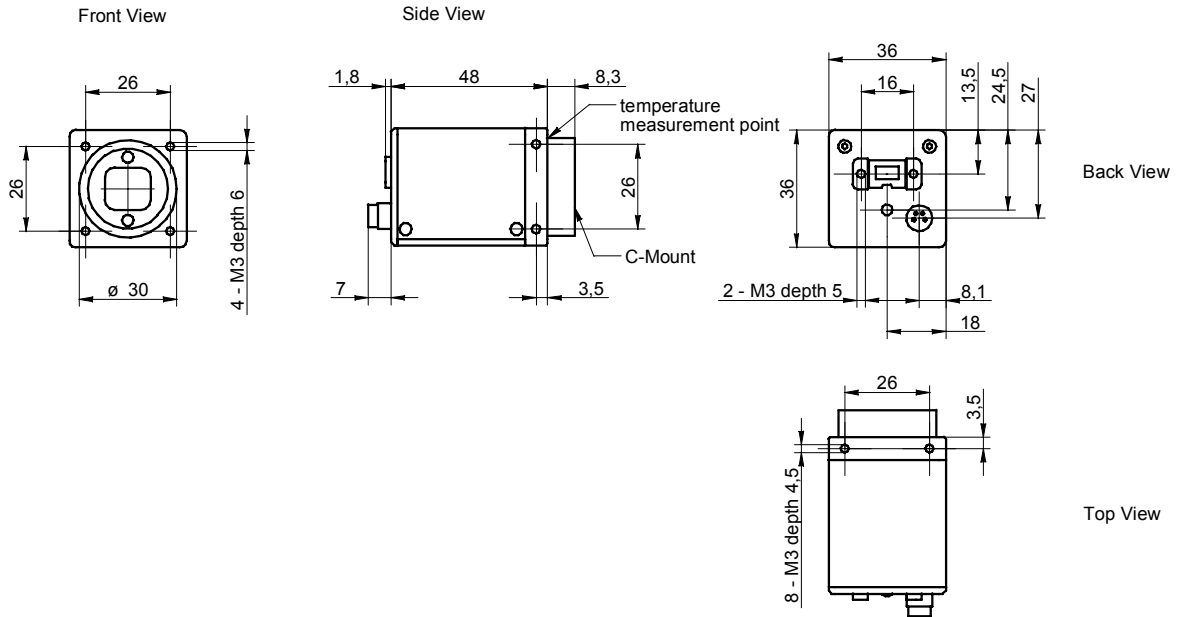

7. Connectors / Electrical Interfaces

7.1 Pin assignment:

IEEE1394b	Pin
	1: TPB- 2: TPB+ 3: TPA- 4: TPA+ 5: GND A 6: GND Power 7: not used 8: Voltage Power 9: GND B

Trigger Flash	Type: Lumberg RSMESD 4pin.
	<p>*) resistor must be used, $I_{OUT} = 16 \text{ mA}$ by $U_{EXT} = 24 \text{ VDC}$ recommended, drawing shown above example for using high active signal</p>
	<p>Trigger / Flash cable wires color *): 1 = brown 2 = white 3 = blue 4 = black</p>

*) shielded trigger / flash cable should to be used and ordered separately

7.2 Flash sync sample $U_{EXT} = 24\text{ VDC}$ high active:

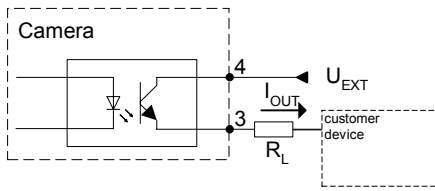

Timing example:
 measurement condition $U_{EXT} = 24\text{ VDC} / I_{OUT} = 16\text{ mA}$

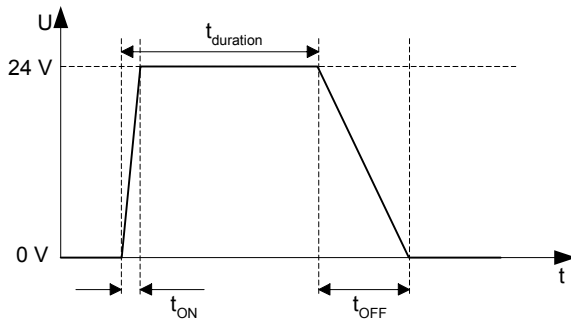

t_{ON} time = typ. 2 μsec
 t_{OFF} time = typ. 40 μsec

7.3 Flash sync sample $U_{EXT} = 24\text{ VDC}$ low active:

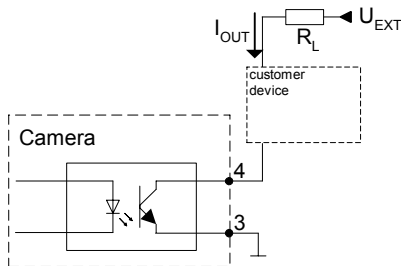

Timing example:
 measurement condition $U_{EXT} = 24\text{ VDC} / I_{OUT} = 16\text{ mA}$

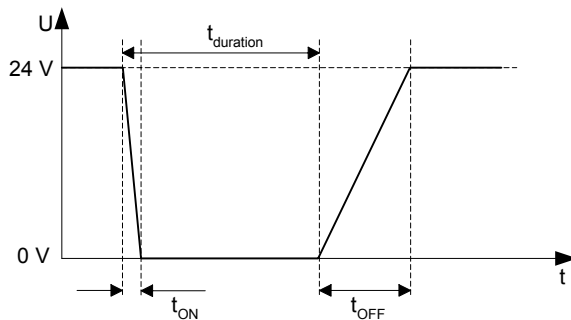

t_{ON} time = typ. 2 μsec
 t_{OFF} time = typ. 40 μsec

End of Document

Technical specifications subject to change