

**Digital Monochrome (b/w)
Progressive Scan Camera**

 System: **IEEE1394b**
Baumer TXF08

 Art. No: **OD107791**

- FireWire™ – IEEE1394b (800 Mbit / sec) progressive scan CCD-camera
- 1032 x 776 pixel
- Up to 28 full frames per second
- Outstanding image quality
- High sensitivity and dynamic range
- High quality slow scan mode for lowest readout noise
- Binning and true partial scan function (ROI) for increased frame rates
- External synchronization via industrial compliant process interface (trigger / flash)
- Integrated 32 MByte RAM for temporarily image data buffering
- Camera parameter programmable in real-time
- Ultra compact and lightweight aluminum housing
- Bilingual: FireWire™ – IEEE1394b and IEEE1394a compatible
- Screw-lock type industrial connector
- Baumer-GAPI: Flexible, generic software interface for Windows / Linux
- User-friendly Baumer TWAIN compatible image capture and camera control software



shown lens needs to be ordered separately

1. Overview

Sensor	1/3" interline progressive scan CCD
Shutter / readout mode	global shutter / progressive scan readout
Number of pixel	1032 x 776
Scan area	4.80 mm x 3.61 mm
Pixel size	4.65 µm x 4.65 µm
Color filter	-
Operation modes	
Trigger mode	yes, overlapped operation
Free running mode	yes, overlapped operation
Signal processing	real-time software programmable
Pixel clock	29.75 MHz fast scan / 14.87 MHz high quality (HQ) scan
A/D converter	12 bit
Exposure control (t_{exp})	total: 4 µsec .. 60 sec step 1 µsec
Gain control	0 .. 20 dB
Offset (black level)	0 .. 255 LSB (12 bit)
Image data buffer	32 MByte
Image acquisition	
Data format	raw image data from camera

Technical specifications subject to change

Camera image format modes (see item 3)	Format (pixel)	Bit per pixel	Pixel clock MHz	Frames per sec. *)	t _{readout}	
Full frame	slow	1032 x 776	12 / 8	14.87	14	71 msec
	fast		12 ** / 8	29.75	28	36 msec
Binning 2x2	slow	516 x 388	12 / 8	14.87	24	42 msec
	fast		12 / 8	29.75	49	20 msec
Partial scan function	yes, format freely programmable in all modes (binning on partial scan ok)					
Brightness correction function	optional in all binning modes					
Look up table function	on request: user programmable (input 12 bit, output 12 bit / 8 bit) or Gamma					
Test pattern function	yes, in all modes					
Data quality	at 20 °C, gain = 1, exposure time = 32 msec, full frame mode, slow scan					
Readout noise	$\sigma < 0.5$ LSB (8 bit) typical					
Dynamic range	typical > 54 dB					
Optical interface	C-Mount on request: CS-Mount					
Optical filter	dust protection on request: super polished, IR cut filter, daylight filter or no filter					
Process interface functions						
Async. trigger	yes, trigger mode operation, software trigger and external trigger separately selectable external trigger in trigger mode 0 (overtriggered signals and trigger signals during the readout time will be notified in the received image header)					
External flash sync	yes, delay_value ≤ 4 μ sec duration_value (t _{duration}): slow mode = t _{exp} + 100 μ sec fast mode = t _{exp} + 50 μ sec					
Software reset	yes, delay up to 102 msec					
Asynchronous reset	Full frame	slow	delay up to 13.9 msec			
		fast	7.2 msec			
	Binning 2x2	slow	delay up to 11.6 msec			
		fast	5.8 msec			
Image info header	yes					
User defined identifier	on request: user programmable permanent identifier					
Electrical interface						
Data / control / power	standard single cable IEEE1394b bilingual / 9 pins option: screw lock type connector					
Digital input	1: trigger signal, opto decoupled U _{IN(low)} = 0 .. 4.5 VDC, U _{IN(high)} = 11 .. 30 VDC I _{IN} = 20 mA (typical) rising edge / invert value = true *** min. trigger impulse length (t _{min}): 2 μ sec trigger delay out of t _{readout} (t _{delay trigger}): 5 μ sec max. trigger delay during t _{readout} (t _{delay trigger}): slow mode = 100 μ sec fast mode = 50 μ sec					
Digital output	1: flash sync signal, opto decoupled U _{EXT} = 5 .. 30 VDC / 24 VDC typical, I _{OUT} = 16 mA **** high active / invert value = true *** flash delay (t _{delay flash}): ≤ 4 μ sec					
LED	green: power on / yellow: data transmission active					
Power consumption	VCC: 8 .. 33 V I: 300 mA .. 100 mA approx. 3 Watt					
Environmental						
Storage temperature	-10 °C .. +70 °C					
Operating temperature	+5 °C .. +50 °C					
Humidity	10 % .. 90 % non condensing					
Conformity	CE, FCC Part 15 class B, RoHS					

Technical specifications subject to change

Housing	aluminum
Dimensions	36 x 36 x 48 mm ³
Weight	< 90 g
IEEE1394 interface	800 / 400 / 200 / 100 Mbit / sec
Software	Baumer FCAM1394 driver / Baumer OHCI driver SDK for Windows 2000 / Windows XP / Windows Vista / Linux Kernel 2.4.>22, 2.6.xx supported .net platform Baumer TWAIN image capture and camera control software

- *) maximum frame rate in free running mode, effective frame rate depending on camera image format mode settings set exposure time ($t_{exp} < t_{readout}$) and used IEEE1394 interface
- ***) maximum frame rate only available with IEEE1394b (800 Mbit / sec) interface
- ****) can be inverted via software
- *****) necessary for optimal timing specification

2. Camera Factory Settings after Camera Start-up

	Camera factory settings after camera start-up
Operation modes	free running mode
Signal processing	
Exposure control	32 msec
Gain control	factor 1 = 0 dB
Offset (black level)	0
Image acquisition	
Camera image format mode	mode ID = 0: full frame HQ 8 bit (see item 3)
Partial scan function	not active
Electrical interface	
Flash sync signal	disabled, digital output set to low status invert value = true
Async. Trigger	disabled invert value = true

3. Supported Image Formats via fxlib.dll (Baumer FCAM driver)

Camera name		TXF08				
Camera mode		SDK image mode				
	Bit per pixel	Mode ID	Image format	Description	Color coding	Functions / State
Full Frame slow	8	00	1032 x 776	Full Frame HQ 8 bit	RawMono8, Mono8	PS, T, F, Mono
Full Frame slow	12	01	1032 x 776	Full Frame HQ 12 bit	RawMono8, Mono8 RawMono12, Mono12	PS, T, F, Mono
Full Frame fast	8	02	1032 x 776	Full Frame 8 bit	RawMono8, Mono8	PS, T, F, Mono
Full Frame fast *)	12	03	1032 x 776	Full Frame 12 bit	RawMono8, Mono8 RawMono12, Mono12	PS, T, F, Mono
Binning 2x2 slow	8	04	516 x 388	Binning 2x2 HQ 8 bit	RawMono8, Mono8	PS, T, F, BRC, Mono
Binning 2x2 slow	12	05	516 x 388	Binning 2x2 HQ 12 bit	RawMono8, Mono8 RawMono12, Mono12	PS, T, F, BRC, Mono
Binning 2x2 fast	8	06	516 x 388	Binning 2x2 8 bit	RawMono8, Mono8	PS, T, F, BRC, Mono
Binning 2x2 fast	12	07	516 x 388	Binning 2x2 12 bit	RawMono8, Mono8 RawMono12, Mono12	PS, T, F, BRC, Mono

*) maximum frame rate only available with IEEE1394b (800 Mbit / sec) interface

SDK - Software Development Kit
 BRC - brightness correction
 PS - partial scan
 T - trigger
 F - flash
 Mono - monochrome mode

RawMono8 [12] - unmanipulated pixel data for monochrome camera modes in 8 [12] bit
 Mono8 [12] 3 software corrected image data for monochrome camera modes in 8 [12] bit

4. Timing Operation Modes

Trigger Mode: start up time

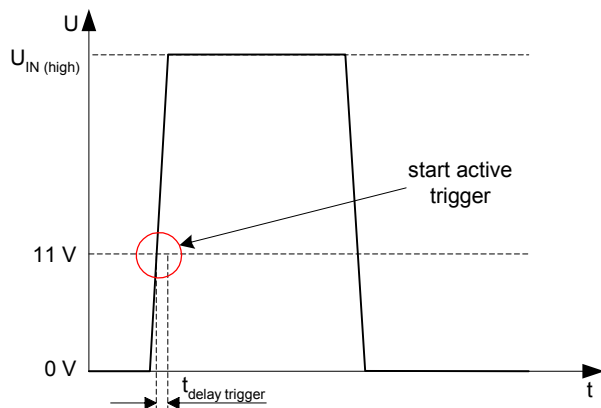

Trigger Mode: trigger mode 0, overlapped trigger

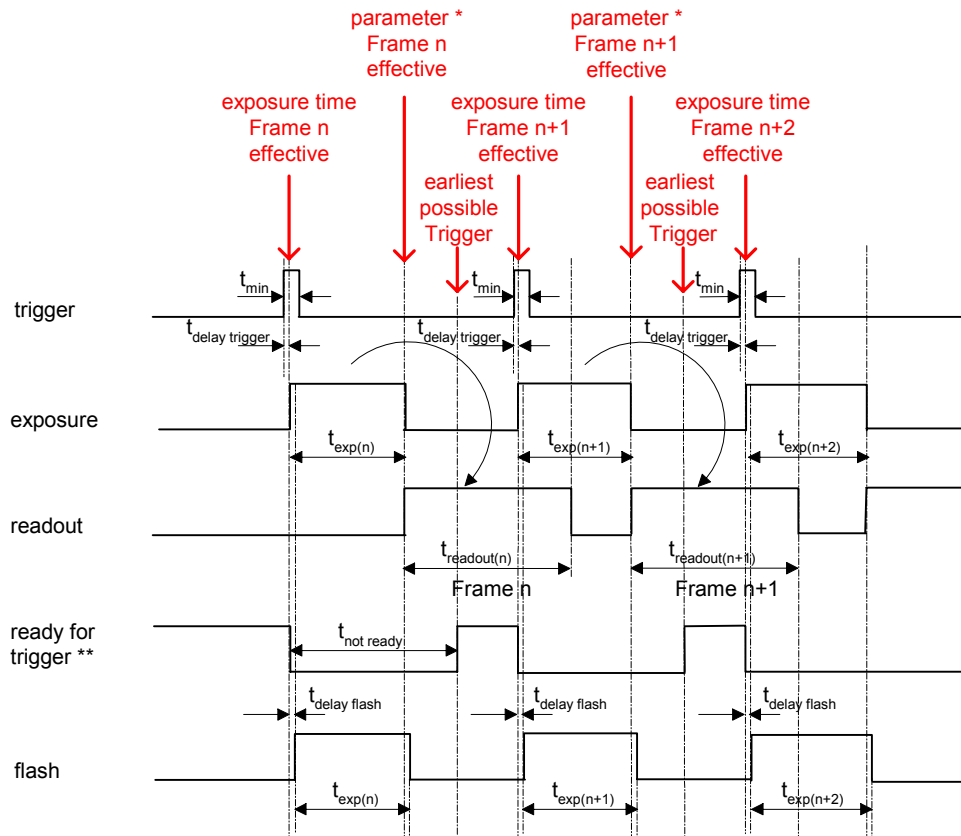

$$t_{exp} < t_{readout} : t_{earliest\ possible\ trigger\ (n+1)} = t_{readout(n)} - t_{exp(n+1)}$$

$$t_{exp} > t_{readout} : t_{earliest\ possible\ trigger\ (n+1)} = t_{exp(n)}$$

$$t_{exp} < t_{readout} : t_{not\ ready\ (n+1)} = t_{exp(n)} + t_{readout(n)} - t_{exp(n+1)}$$

$$t_{exp} > t_{readout} : t_{not\ ready\ (n+1)} = t_{exp(n)}$$

* image parameter: offset
 global gain
 mode
 partial scan

** signal is not available as digital output

Trigger Mode: trigger mode 0, overlapped trigger , when $t_{exp(n+2)} > t_{exp(n+1)}$

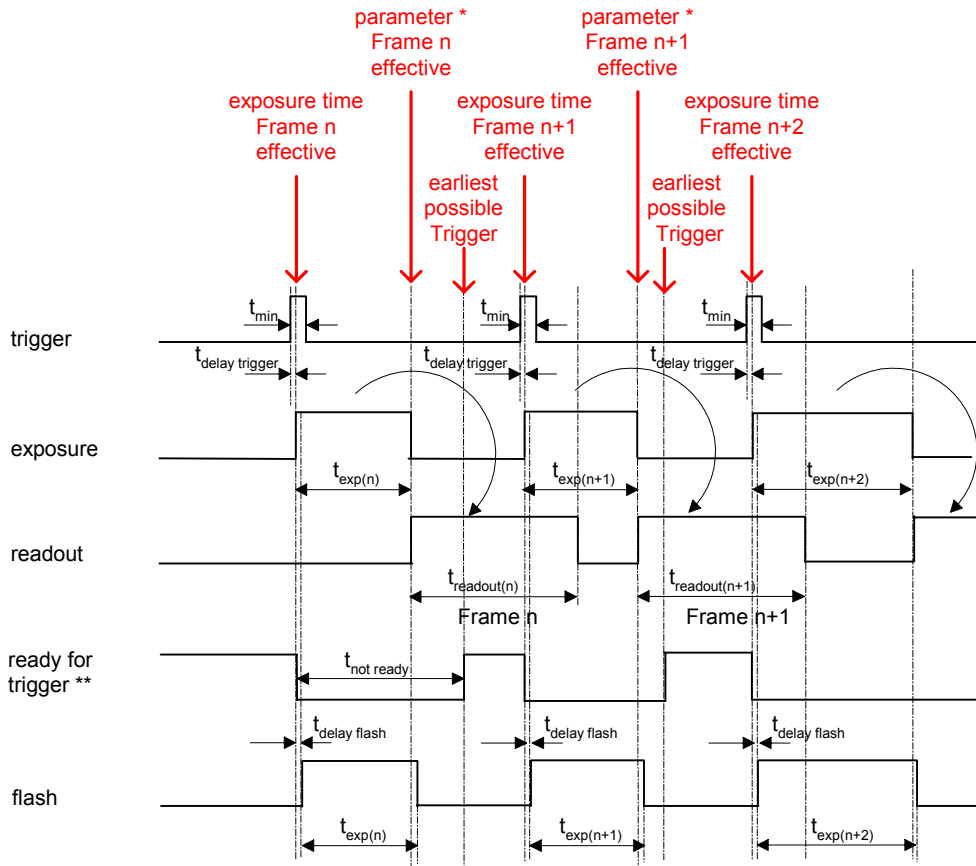

$$t_{exp} < t_{readout}: t_{earliest\ possible\ trigger\ (n+1)} = t_{readout(n)} - t_{exp(n+1)}$$

$$t_{exp} > t_{readout}: t_{earliest\ possible\ trigger\ (n+1)} = t_{exp(n)}$$

$$t_{exp} < t_{readout}: t_{not\ ready\ (n+1)} = t_{exp(n)} + t_{readout(n)} - t_{exp(n+1)}$$

$$t_{exp} > t_{readout}: t_{not\ ready\ (n+1)} = t_{exp(n)}$$

* image parameter: offset
 global gain
 mode
 partial scan

** signal is not available as digital output

Trigger Mode: trigger mode 0, overlapped trigger , when $t_{exp(n+2)} < t_{exp(n+1)}$

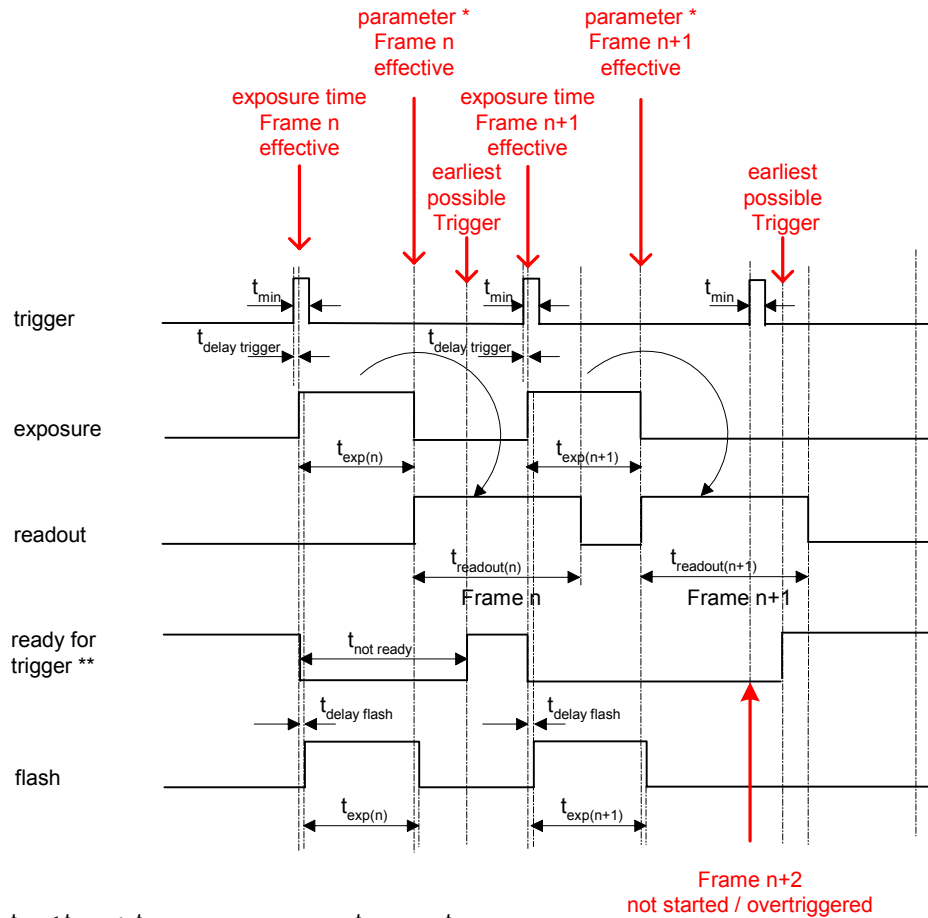

$$t_{exp} < t_{readout} : t_{earliest\ possible\ trigger\ (n+1)} = t_{readout(n)} - t_{exp(n+1)}$$

$$t_{exp} > t_{readout} : t_{earliest\ possible\ trigger\ (n+1)} = t_{exp(n)}$$

$$t_{exp} < t_{readout} : t_{not\ ready\ (n+1)} = t_{exp(n)} + t_{readout(n)} - t_{exp(n+1)}$$

$$t_{exp} > t_{readout} : t_{not\ ready\ (n+1)} = t_{exp(n)}$$

Frame n+2
not started / overtriggered

* image parameter: offset
global gain
mode
partial scan

** signal is not available as digital output

Free Running Mode: overlapped operation

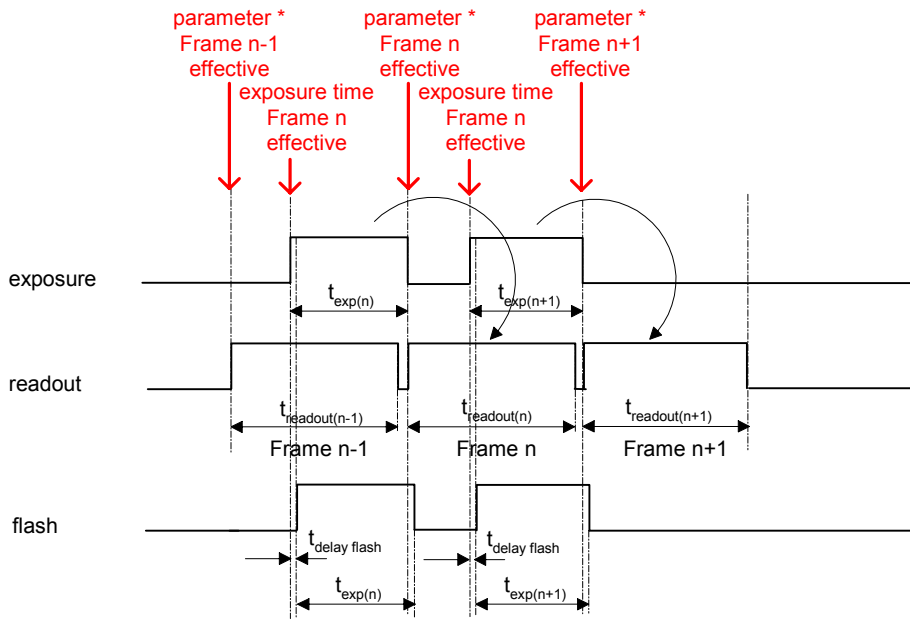

* image parameter: offset
 global gain
 mode
 partial scan

5. Housing

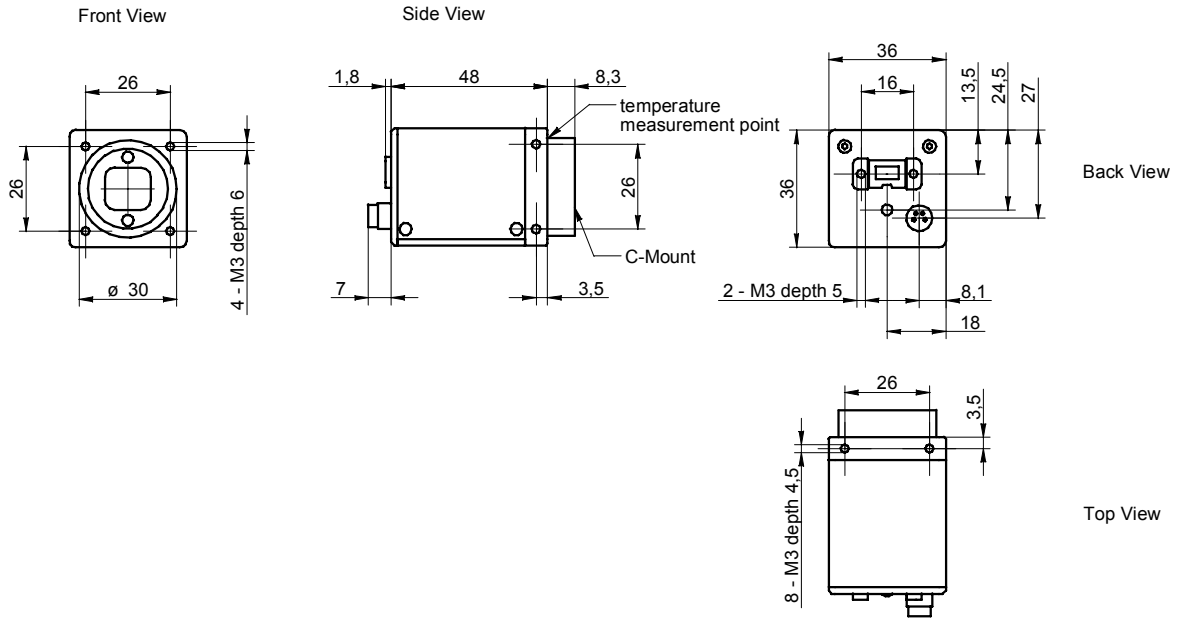

6. Connectors / Electrical Interfaces

6.1 Pin assignment:

IEEE1394b	Pin
	1: TPB- 2: TPB+ 3: TPA- 4: TPA+ 5: GND A 6: GND Power 7: not used 8: Voltage Power 9: GND B

Trigger Flash	Type: Lumberg RSMESD 4pin.
	<p>*) resistor must be used, $I_{OUT} = 16 \text{ mA}$ by $U_{EXT} = 24 \text{ VDC}$ recommended, drawing shown above example for using high active signal</p>
	Trigger / Flash cable wires color *): 1 = brown 2 = white 3 = blue 4 = black

*) shielded trigger / flash cable should be used and ordered separately

6.2 Flash sync sample $U_{EXT} = 24$ VDC high active:

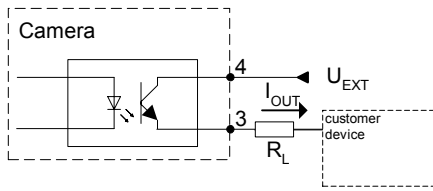

Timing example:
 measurement condition $U_{EXT} = 24$ VDC / $I_{OUT} = 16$ mA

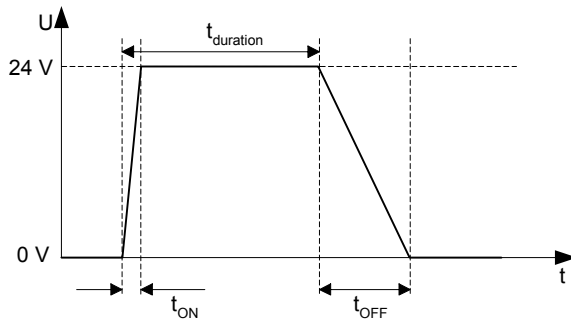

t_{ON} time = typ. 2 μ sec
 t_{OFF} time = typ. 40 μ sec

6.3 Flash sync sample $U_{EXT} = 24$ VDC low active:

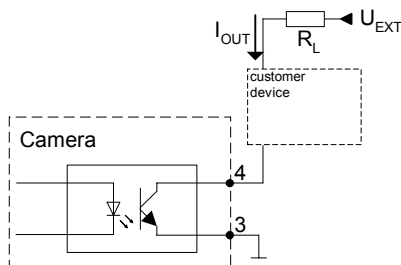

Timing example:
 measurement condition $U_{EXT} = 24$ VDC / $I_{OUT} = 16$ mA

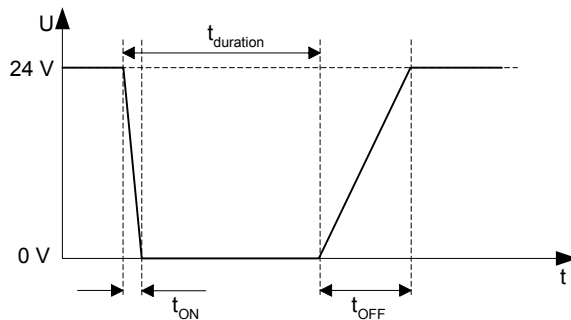

t_{ON} time = typ. 2 μ sec
 t_{OFF} time = typ. 40 μ sec

End of Document