

**Digital Color
Progressive Scan Camera**

System: **Gigabit Ethernet**

Baumer TXG13c-I7

Revision 2

Art. No: **OD108607**

- Gigabit Ethernet progressive scan CCD camera
- 1384 x 1036 pixel
- Up to 20 full frames per second
- GigE Vision™ standard compliant
- On board integrated color processor for high quality color calculation
- Outstanding image quality
- High sensitivity and dynamic range
- High quality slow scan mode for lowest readout noise
- True partial scan function (ROI) for increased frame rates
- External synchronization via industrial compliant process interface (trigger / flash)
- Integrated supplementary function for flexible integration
- Jumbo frames supported
- Integrated 32 MByte RAM for temporarily image data buffering
- Camera parameter programmable in real-time
- Ultra compact and lightweight aluminum housing
- IP67 camera housing design based on EHEDG recommendation
- Standard M12 industrial connector
- Baumer-GAPI: Flexible, generic software interface for Windows / Linux



shown lens and tubes need to be ordered separately

1. Overview

Model Name	TXG13c
Sensor	1/2" interline progressive scan CCD
Shutter / readout mode	global shutter / progressive scan readout
Number of pixel	1384 x 1036
Scan area	6.44 mm x 4.82 mm
Pixel size	4.65 µm x 4.65 µm
Color filter	RGB Bayer mosaic
Operation modes	
Trigger mode	yes, overlapped operation
Free running mode	yes, overlapped operation
Signal processing	real-time software programmable
Pixel clock	40 MHz fast scan / 20 MHz high quality (HQ) scan
A/D converter	12 bit
Exposure control (t _{exp})	total: 4 µsec .. 60 sec step: 1 µsec
Gain control	0 .. 20 dB
Offset (black level)	0 .. 255 LSB (12 bit)
Image data buffer	max. 3 images

Technical specifications subject to change

Image acquisition							
Camera image format modes	Format (pixel)	GenCam standard	Format ID	Pixel format	Pixel clock MHz	Frames per sec. *)	t _{readout}
Full frame HQ slow	1384 x 1036	Vendor specific	00	BayerRG8	20	10	100 msec
				BayerRG12			
				Mono8			
				YUV411 Packed			
				YUV422 Packed **)			
				YUV444 Packed			
				RGB8 Packed			
Full frame fast	1384 x 1036	yes	01	BayerRG8	40	20	50 msec
				BayerRG12			
				Mono8			
				YUV411 Packed			
				YUV422 Packed **)			
				YUV444 Packed			
				RGB8 Packed			
BGR8 Packed							
Standard features							
Image size controls							
Pixel format	BayerRG8, BayerRG12, Mono8, YUV411 Packed, YUV422 Packed, YUV444 Packed, RGB8 Packed, BGR8 Packed						
Test image selector	yes, in all modes Off, GreyHorizontalRamp, GreyVerticalRamp, HorizontalLineMoving, VerticalLineMoving, HorizontalAndVerticalLineMoving						
Partial scan	yes, format freely programmable in all modes						
Analog controls							
Gain	yes						
Black Level (Off set)	yes						
Gamma	no						
Acquisition and Trigger							
Acquisition mode	Continuous						
Trigger source	HardwareTrigger (Line0), SoftwareTrigger, CommandTrigger (ActionCommand), All or Off						
Trigger delay	0 .. 2 sec, 512 trigger can be tracked, step: 1 µsec						
Sequencer	no						
Digital I/O							
Lines	Line0 (Input), Line1 (Output)						
Line source (outputs only)	Line1: Off, ExposureActive or UserOutput						
Line debouncer	yes, low and high signal separately selectable 0 .. 5 msec step: 1µsec						
Event Generation							
Events	GigEVisionError, EventLost, Line0RisingEdge, Line0FallingEdge, Line1RisingEdge, Line1FallingEdge, ExposureStart, ExposureEnd, FrameStart, FrameEnd, TriggerReady, TriggerOverlapped, TriggerSkipped						
Event Notification	yes, ON / OFF						
Counters and Timers							
Framecounter	yes, 2 ³² can be set by user						
LUT Controls							
LUT selector	no						
Defect pixel correction (custom)	yes, ON / OFF						
Defect pixel list (custom)	yes, max. 256 pixel coordinates (x, y) can be stored						
GigEVisionTransportLayer							
PayLoadsize	4 Byte .. 4.301.744 Byte						
UserSets							
User set selector	Default (factory settings / read only) UserSet1, UserSet2, UserSet3 (read and write)						
UserSetDefaultSelector	yes, define the start up "UserSet"						

Housing	aluminum			
Dimensions	Ø 65 mm x 50 mm			
Weight camera	< 360 g			
Weight tube	52 mm < 120 g	62 mm < 140 g	71 mm < 150 g	94 mm < 200 g
1000 Base-T interface	1000 Mbit / sec			
Ethernet IP configuration	persistent IP / DHCP / LLA			
Stream channel packet size	576 Byte (default) .. 16 kByte jumbo frames supported			
Interpacketgap	0 .. 2 ³² -1 ticks			
Resend function	yes			
Software	Baumer-GAPI SDK with supported OS socket driver and Baumer filter driver / SDK for Windows XP (32 bit) / Windows Vista (32 bit / 64bit) Linux Kernel 2.6.xx (64 bit / 32 bit)			
	GigE Vision™ compatible programs and image processing libraries supported Windows / Linux depending on the actually driver software is used			

- *) maximum frame rate in free running mode, effective frame rate depending on camera image format mode settings and set exposure time ($t_{exp} < t_{readout}$)
- **) default pixel format
- ***) can be inverted via software
- ****) housing temperature is limited by CCD sensor specification

2. Camera Factory Settings after Camera Start-up

	Camera factory settings after camera start-up
Operation modes	free running mode
Signal processing	
Exposure control	32 msec
Gain control	factor 1 = 0 dB
Offset (black level)	0
Image acquisition	
Camera image format mode	mode id = 01, full frame YUV422 Packed
Partial scan function	not active
Test image selector	Off
Defect pixel correction	On
Electrical interface	
Exposure Active (External flash sync)	disabled, digital output set to low status (high impedance) invert = false line source = Exposure Active
Async. Trigger	disabled invert = false trigger source = Line0

3. Timing Operation Modes

Trigger Mode: start up time

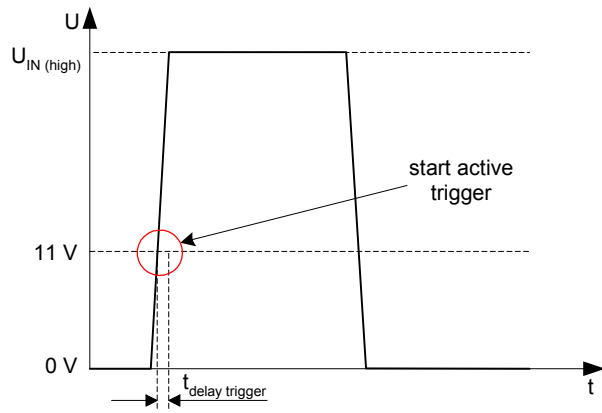

Trigger Mode: trigger mode 0, overlapped trigger

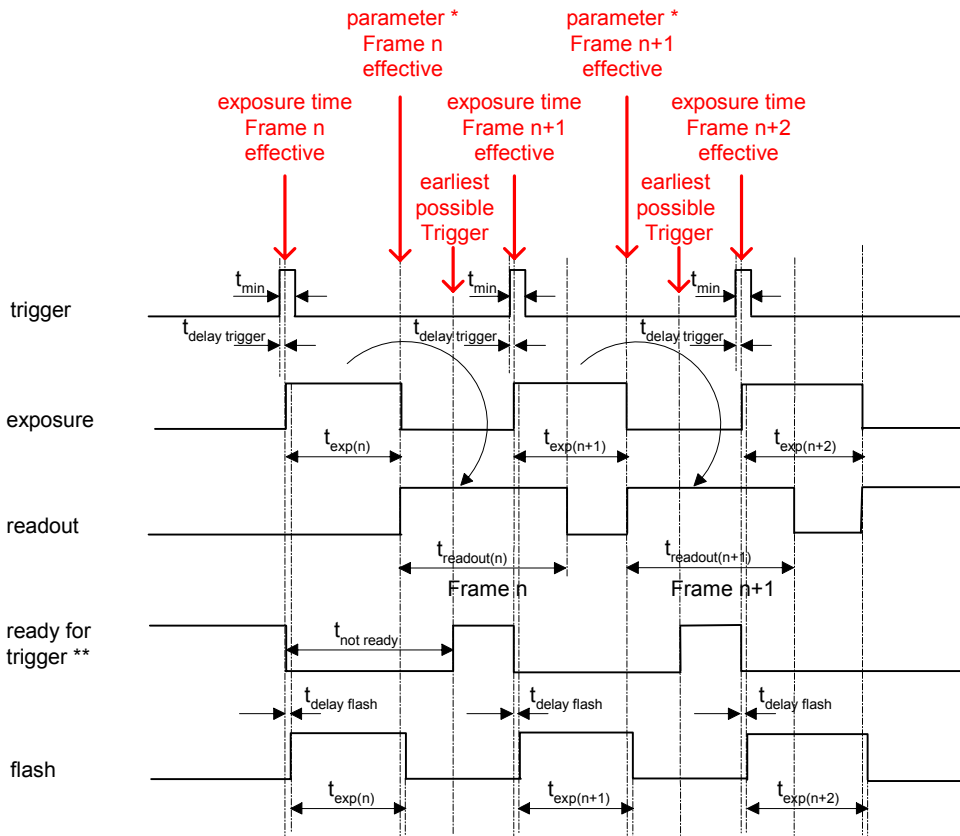

$$t_{exp} < t_{readout}: t_{earliest\ possible\ trigger\ (n+1)} = t_{readout(n)} - t_{exp(n+1)}$$

$$t_{exp} > t_{readout}: t_{earliest\ possible\ trigger\ (n+1)} = t_{exp(n)}$$

$$t_{exp} < t_{readout}: t_{not\ ready\ (n+1)} = t_{exp(n)} + t_{readout(n)} - t_{exp(n+1)}$$

$$t_{exp} > t_{readout}: t_{not\ ready\ (n+1)} = t_{exp(n)}$$

* image parameter: offset
global gain
mode
partial scan

** signal will be notified as event "TriggerReady" and is not available as digital output

Trigger Mode: trigger mode 0, overlapped trigger , when $t_{exp(n+2)} > t_{exp(n+1)}$

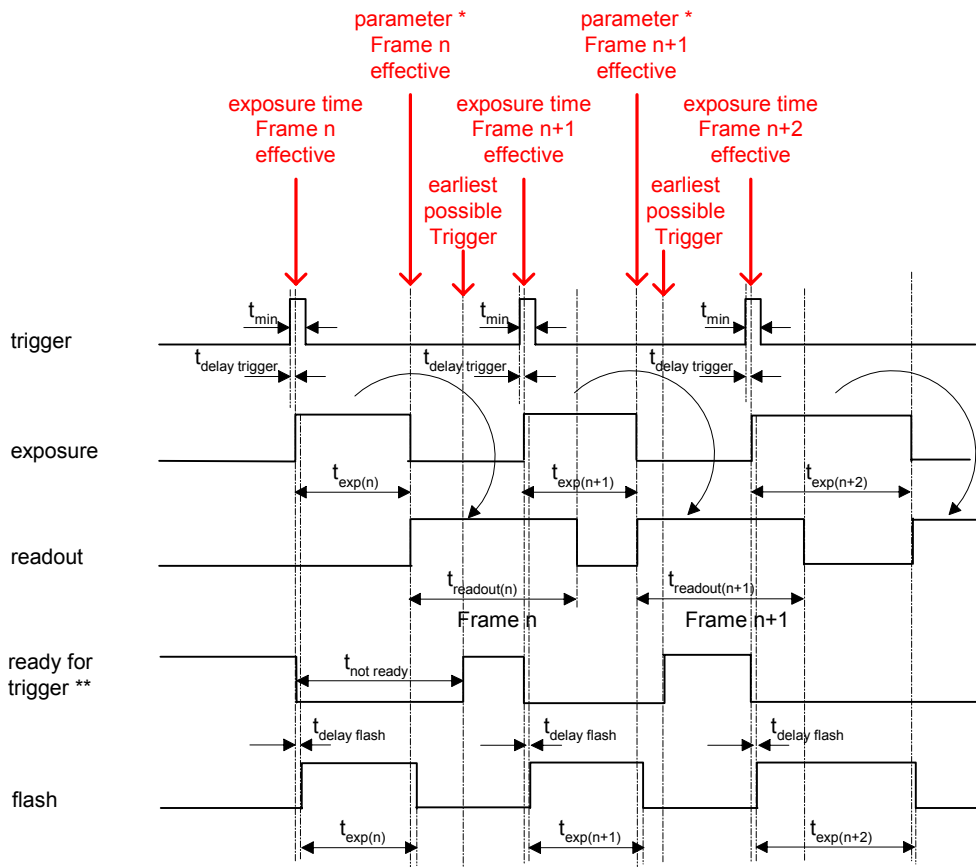

$$\begin{aligned}
 t_{exp} < t_{readout}: t_{earliest\ possible\ trigger\ (n+1)} &= t_{readout(n)} - t_{exp(n+1)} \\
 t_{exp} > t_{readout}: t_{earliest\ possible\ trigger\ (n+1)} &= t_{exp(n)} \\
 t_{exp} < t_{readout}: t_{not\ ready\ (n+1)} &= t_{exp(n)} + t_{readout(n)} - t_{exp(n+1)} \\
 t_{exp} > t_{readout}: t_{not\ ready\ (n+1)} &= t_{exp(n)}
 \end{aligned}$$

* image parameter: offset
 global gain
 mode
 partial scan

** signal will be notified as event "TriggerReady" and is not available as digital output

Trigger Mode: trigger mode 0, overlapped trigger , when $t_{exp(n+2)} < t_{exp(n+1)}$

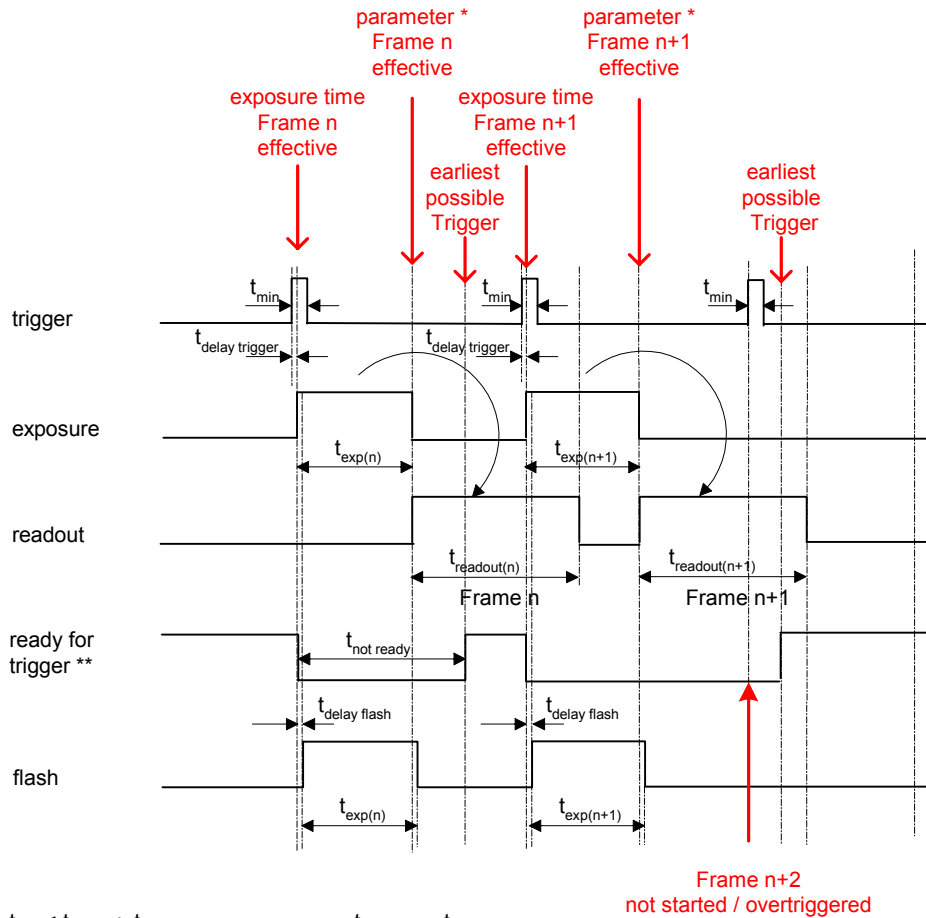

$$t_{exp} < t_{readout} : t_{earliest\ possible\ trigger\ (n+1)} = t_{readout(n)} - t_{exp(n+1)}$$

$$t_{exp} > t_{readout} : t_{earliest\ possible\ trigger\ (n+1)} = t_{exp(n)}$$

$$t_{exp} < t_{readout} : t_{not\ ready\ (n+1)} = t_{exp(n)} + t_{readout(n)} - t_{exp(n+1)}$$

$$t_{exp} > t_{readout} : t_{not\ ready\ (n+1)} = t_{exp(n)}$$

Frame n+2
not started / overtriggered

* image parameter: offset
global gain
mode
partial scan

** signal will be notified as event "TriggerReady" and is not available as digital output

Trigger Mode: overlapped trigger sequence (example for 3 frames per channel with hardware trigger)

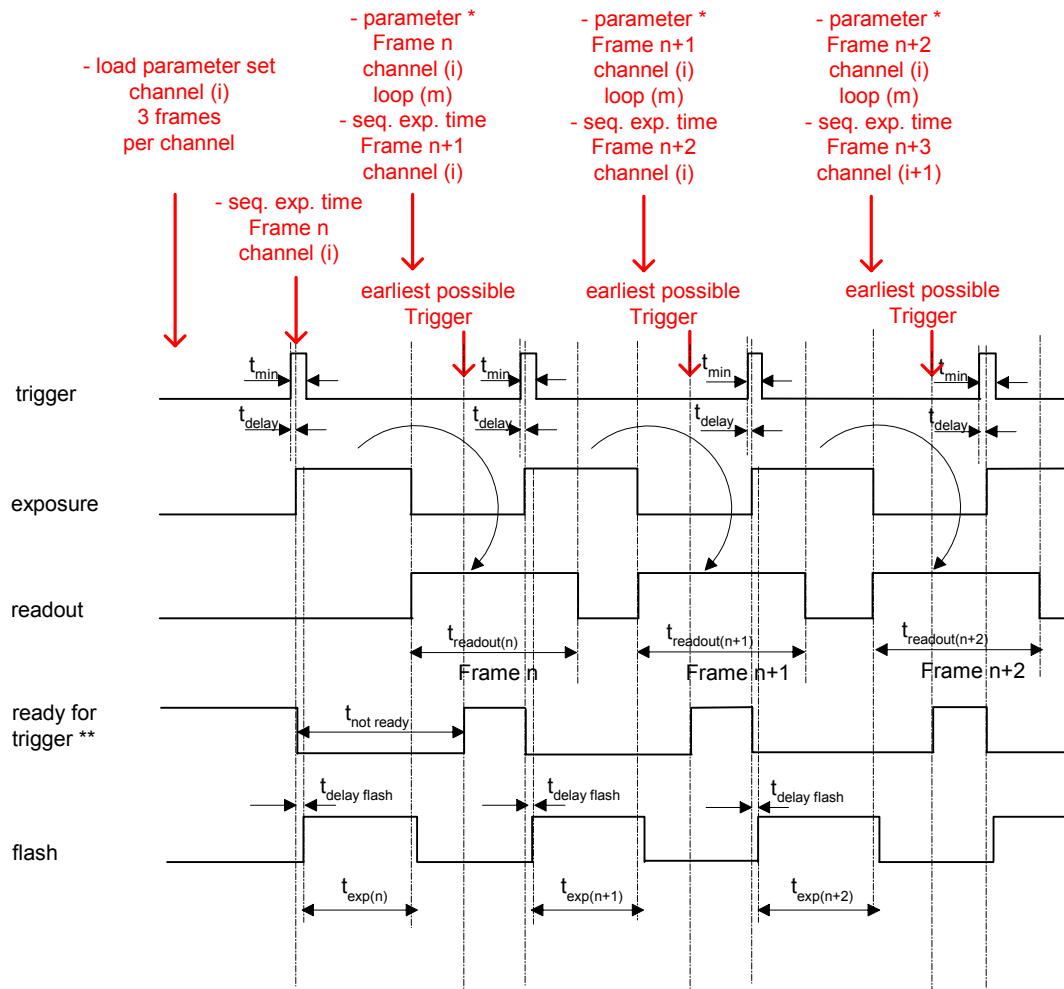

$$t_{exp} < t_{readout}: t_{earliest\ possible\ trigger\ (n+1)} = t_{readout(n)} - t_{exp(n+1)}$$

$$t_{exp} > t_{readout}: t_{earliest\ possible\ trigger\ (n+1)} = t_{exp(n)}$$

$$t_{exp} < t_{readout}: t_{not\ ready\ (n+1)} = t_{exp(n)} + t_{readout(n)} - t_{exp(n+1)}$$

$$t_{exp} > t_{readout}: t_{not\ ready\ (n+1)} = t_{exp(n)}$$

* image parameter: offset
sequence global gain
mode

** signal will be notified as event "TriggerReady" and is not available as digital output

Free Running Mode: overlapped operation

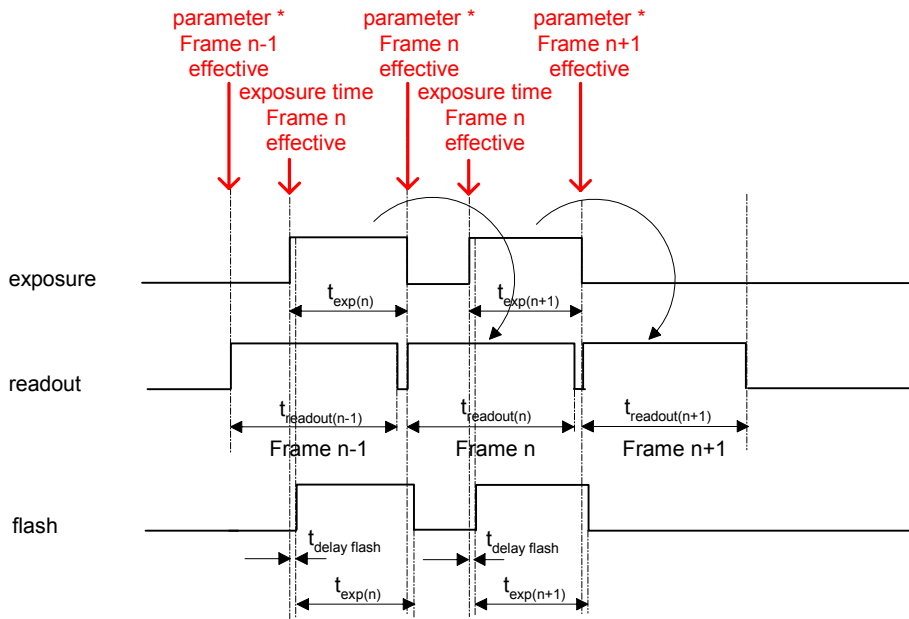

* image parameter: offset
global gain
mode
partial scan

4. Housing

4.1 Camera

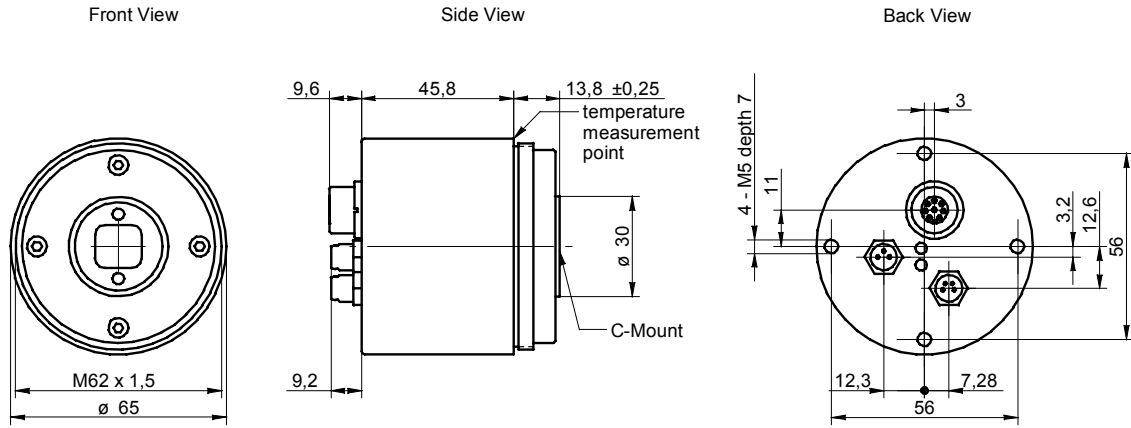

4.2 Tube

Front View

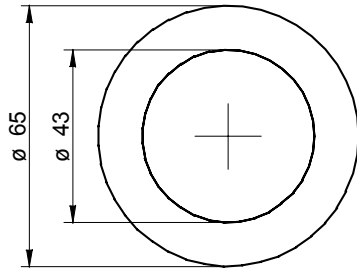

Side View

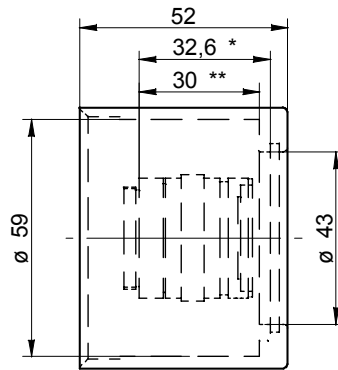

Item Number

OD108571

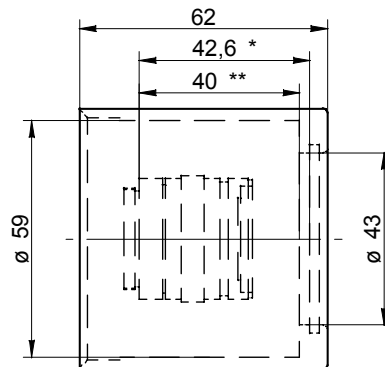

OD108568

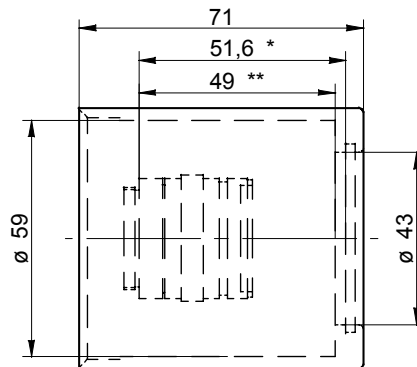

OD108569

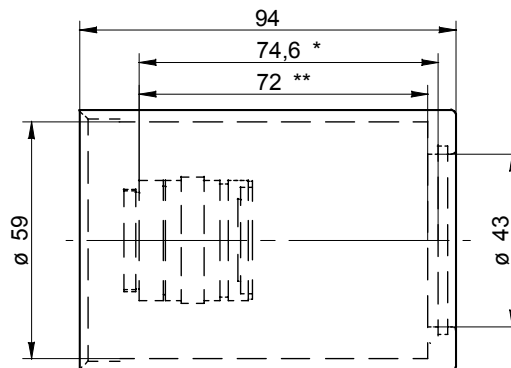

OD108570

* max. installation space between C-mount and glass
 ** max. installation space between C-mount and cylinder bottom

5. Connectors / Electrical Interfaces

5.1 Pin assignment:

Data / Control 1000 Base-T	Type: female M12 / 8 pin A cod.
	1: MX3- 2: MX4+ 3: MX4- 4: MX1- 5: MX2+ 6: MX1+ 7: MX3+ 8: MX2-

Power	Type: Lumberg RSMEESD / 3 pin
	1: Power VCC+ 3: GND 4: not used
	Power cable wires color: 1 = brown 3 = blue 4 = black

Trigger Flash	Type: Lumberg RSMEESD 4pin.
	*) resistor must be used, $I_{OUT} = 16 \text{ mA}$ by $U_{EXT} = 24 \text{ VDC}$ recommended, drawing shown above example for using high active signal
	Trigger / Flash cable wires color *): 1 = brown 2 = white 3 = blue 4 = black

*) shielded trigger / flash cable should be used and ordered separately

5.2 Flash sync sample $U_{EXT} = 24\text{ VDC}$ high active:

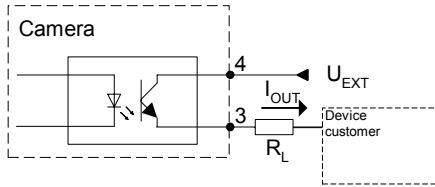

Timing example:
 measurement condition $U_{EXT} = 24\text{ VDC} / I_{OUT} = 16\text{ mA}$
 $R_L = 1.5\text{ kOhm}$

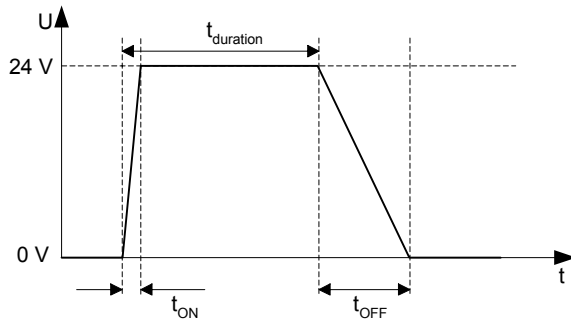

t_{ON} time = typ. $2\ \mu\text{sec}$
 t_{OFF} time = typ. $40\ \mu\text{sec}$

5.3 Flash sync sample $U_{EXT} = 24\text{ VDC}$ low active:

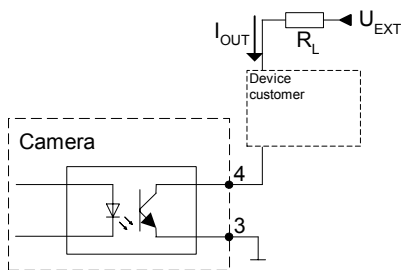

Timing example:
 measurement condition $U_{EXT} = 24\text{ VDC} / I_{OUT} = 16\text{ mA}$
 $R_L = 1.5\text{ kOhm}$

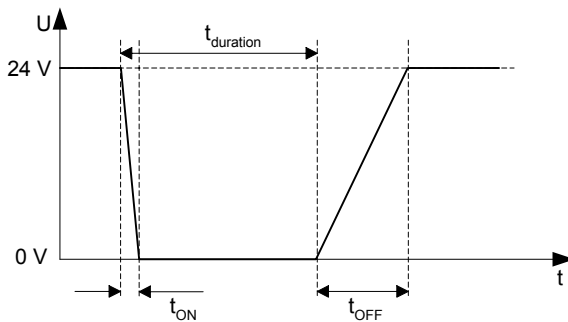

t_{ON} time = typ. $2\ \mu\text{sec}$
 t_{OFF} time = typ. $40\ \mu\text{sec}$

End of Document